

Double-Acting Round-Line Cylinders According to ISO 6432 with Magnetic Piston (Buffer Cushioning)

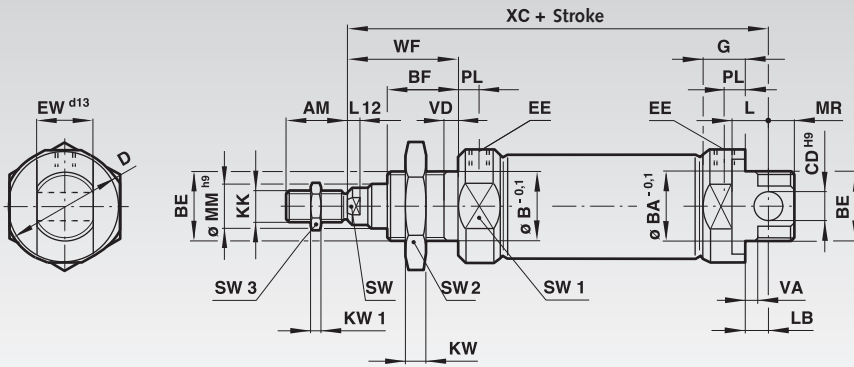

Materials: Profile Barrel: Stainless Steel (austenitic).
End Covers: Anodised Aluminium, Piston Rod: Stainless Steel (austenitic), Wiper: Polyurethane, Buffer cushioning: Polyurethane, Seals: NBR.

Medium: Compressed air, filtered, lubricated or non-lubricated.
Standard: ISO 6432.

Mode of Operation: Double-acting with magnetic piston and buffer cushioning.

Operating pressure: 1 to 10 bar.

Operating temperature: max. +80 °C.

Ordering Details: e.g.: Product No. 805 100 10, Double-Acting Round-Line Cylinder according to ISO 6431 with Magnet Piston, Cylinder Ø 10 mm, Stroke 10 mm

Cylinder Ø mm	Theoretical Forces at 6 bar (N)	
	Thrust	Pull
10	47,1	39,6
12	67,8	51
16	120	104
20	188	158
25	294	247

Symbol



Product No.		Standard Strokes						Cylinder Ø mm	Connection
10 mm	25 mm	50 mm	80 mm	100 mm	125 mm	160 mm	200 mm		
805 100 10	805 100 25	-	-	-	-	-	-	10	M5
805 120 10	805 120 25	-	-	-	-	-	-	12	M5
805 160 10	805 160 25	805 160 50	-	-	-	-	-	16	M5
805 200 10	805 200 25	805 200 50	805 200 80	805 201 00	805 201 25	805 201 60	805 202 00	20	G ¹ / ₈
805 250 10	805 250 25	805 250 50	805 250 80	805 251 00	805 251 25	805 251 60	805 252 00	25	G ¹ / ₈

Cyl. Ø mm	AM mm	Ø B/BA ^{-0,1} mm	BE mm	BF mm	Ø CD ^{H9} mm	Ø D mm	EE mm	EW ^{-0,1} mm	G mm	KK mm	SW2 mm	SW3 mm	KW mm	KW1 mm
10	12	12	M12x1,25	12	4	16,5	M5	7,9	9	M4	19	7	6	2
12	16	16	M16x1,5	17	6	21	M5	11,9	9,5	M6	22	10	5	3
16	16	16	M16x1,5	17	6	21	M5	11,9	9,5	M6	22	10	5	3
20	20	22	M22x1,5	20	8	30	G ¹ / ₈	15,9	15	M8	27	13	8	4
25	22	22	M22x1,5	22	8	30	G ¹ / ₈	15,9	15	M10x1,25	27	17	8	5

Cyl. Ø mm	L mm	L12 mm	LB mm	Ø MM ^{H9} mm	MR mm	PL mm	SW mm	SW1 mm	WF mm	VA/VD mm	XC mm	Weight in kg	
												at 0 mm	per 25 mm
10	6	-	2	4	8	5,5	-	14	16	1,5	64	0,034	0,007
12	9	3	3	6	8	5,5	5	19	22	2	75	0,058	0,011
16	9	3	4	6	7	5,5	5	19	22	2	82	0,070	0,012
20	12	3	3	8	11	8	7	27	24	2	95	0,145	0,018
25	12	4	7	10	9	8	9	27	28	2	104	0,200	0,028

Mounting Elements for Round-Line Cylinders

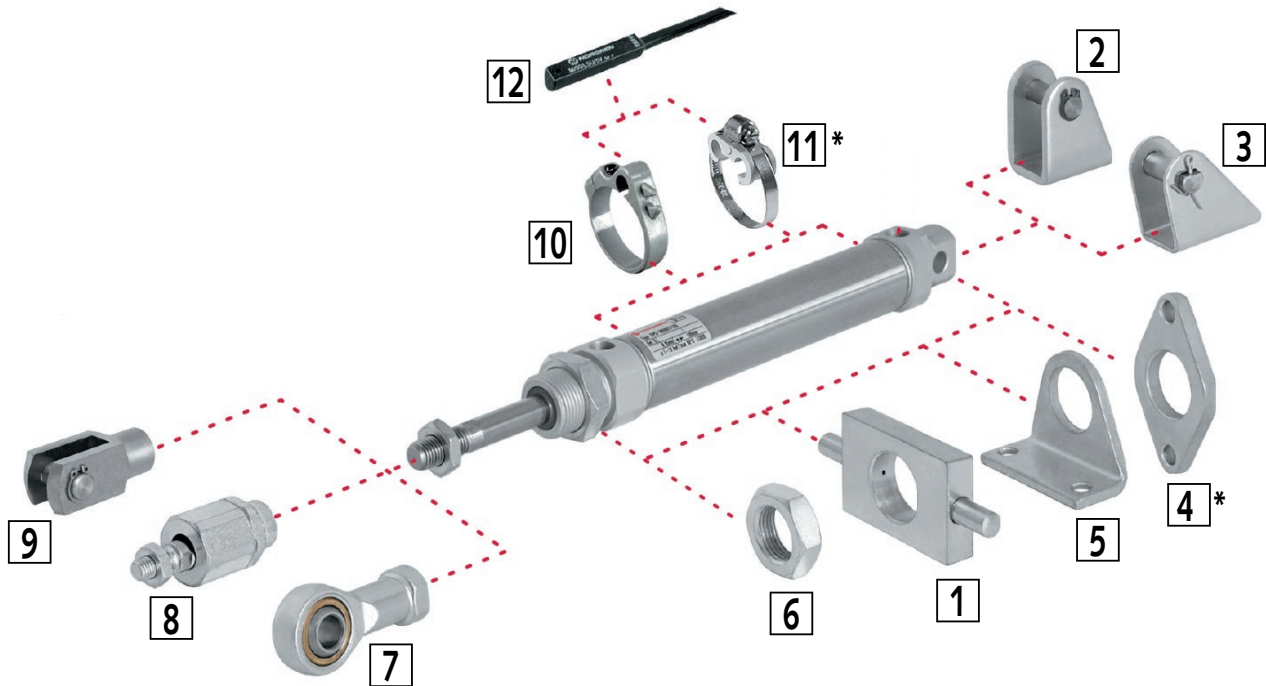

No. Designation	Cylinder Ø 10mm Product No.	Cylinder Ø 12mm Product No.	Cylinder Ø 16mm Product No.	Cylinder Ø 20mm Product No.	Cylinder Ø 25mm Product No.	Dim. Page*
1 Trunnion Mounting	-	810 021 12	810 021 12	810 021 20	810 021 20	996
2 Bracket Hinge Mounting with Circlip	810 023 10	810 023 12	810 023 12	810 023 20	810 023 20	998
3 Bracket Hinge Mounting with Split Pin	810 022 10	810 022 12	810 022 12	810 022 20	810 022 20	998
4 Rear Flange, front Flange*	810 019 10*	810 019 12*	810 019 12*	810 019 20*	810 019 20*	-
5 Foot Plate Mounting	810 020 10	810 020 12	810 020 12	810 020 20	810 020 20	997
6 Piston Rod Lock Nut	810 024 10	810 024 12	810 024 12	810 024 20	810 024 20	997
7 Universal Piston Rod Mounting with Spherical Bearing	810 005 10	810 005 12	810 005 12	810 005 20	810 005 25	996
8 Piston Rod Swivel Mounting	810 000 10	810 000 12	810 000 12	810 000 20	810 000 25	996
9 Clevis	810 003 10	810 003 12	810 003 12	810 003 20	810 003 25	995
10 Mounting Bracket for Magnetic Switches ≥ 15mm Stroke	810 017 10	810 017 12	810 017 16	810 017 20	810 017 25	997
11 Mounting Bracket for Magnetic Switches < 15mm Stroke*	810 018 10*	810 018 12*	810 018 16*	810 018 20*	810 018 25*	-

* Discontinued item.

No. 12: The magnetic switch (product no. 810 000 01 to 810 000 07, page 999) requires the mounting bracket no. 10.