

## AD680\*

### FEATURES

- Low Quiescent Current: 250  $\mu$ A max
- Laser Trimmed to High Accuracy:  
2.5 V  $\pm$  5 mV max (AN, AR Grade)
- Trimmed Temperature Coefficient:  
20 ppm/ $^{\circ}$ C max (AN, AR Grade)
- Low Noise: 8  $\mu$ V p-p from 0.1 Hz to 10 Hz  
250 nV/ $\sqrt{\text{Hz}}$  Wideband
- Temperature Output Pin (N, R Packages)
- Available in Three Package Styles:  
8-Pin Plastic DIP, 8-Pin SOIC and 3-Pin TO-92

### CONNECTION DIAGRAMS

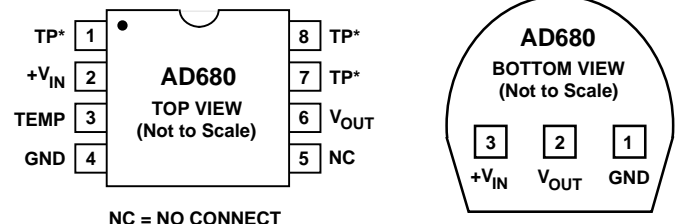

NC = NO CONNECT

\* TP DENOTES FACTORY TEST POINT.  
NO CONNECTIONS SHOULD BE MADE  
TO THESE PINS.

### PRODUCT DESCRIPTION

The AD680 is a bandgap voltage reference which provides a fixed 2.5 V output from inputs between 4.5 V and 36 V. The architecture of the AD680 enables the reference to be operated at a very low quiescent current while still realizing excellent dc characteristics and noise performance. Trimming of the high stability thin-film resistors is performed for initial accuracy and temperature coefficient, resulting in low errors over temperature.

The precision dc characteristics of the AD680 make it ideal for use as a reference for D/A converters which require an external precision reference. The device is also ideal for A/D converters and, in general, can offer better performance than the standard on-chip references.

Based upon the low quiescent current of the AD680, which rivals that of many incomplete two-terminal references, the AD680 is recommended for low power applications such as hand-held battery equipment.

A temperature output pin is provided on the 8-pin package versions of the AD680. The temperature output pin provides an output voltage that varies linearly with temperature and allows the AD680 to be configured as a temperature transducer while providing a stable 2.5 V output.

The AD680 is available in five grades. The AD680AN is specified for operation from  $-40^{\circ}$ C to  $+85^{\circ}$ C, while the AD680JN is specified for  $0^{\circ}$ C to  $+70^{\circ}$ C operation. Both the AD680AN and AD680JN are available in 8-pin plastic DIP packages. The AD680AR is specified for operation from  $-40^{\circ}$ C to  $+85^{\circ}$ C, while the AD680JR is specified for  $0^{\circ}$ C to  $+70^{\circ}$ C operation. Both are available in an 8-pin Small Outline IC (SOIC) package. The AD680JT is specified for  $0^{\circ}$ C to  $+70^{\circ}$ C operation and is available in a 3-pin TO-92 package.

\*Protected by U.S. Patent Nos. 4,902,959; 4,250,445 and 4,857,862.

### REV. C

Information furnished by Analog Devices is believed to be accurate and reliable. However, no responsibility is assumed by Analog Devices for its use, nor for any infringements of patents or other rights of third parties which may result from its use. No license is granted by implication or otherwise under any patent or patent rights of Analog Devices.

### PRODUCT HIGHLIGHTS

1. The AD680 bandgap reference operates on a very low quiescent current which rivals that of many two-terminal references. This makes the complete, higher accuracy AD680 ideal for use in power sensitive applications.
2. Laser trimming of both initial accuracy and temperature coefficients results in low errors over temperature without the use of external components. The AD680AN and AD680AR have a maximum variation of 6.25 mV between  $-40^{\circ}$ C and  $+85^{\circ}$ C.
3. The AD680 noise is low, typically 8  $\mu$ V p-p from 0.1 Hz to 10 Hz. Spectral density is also low, typically 250 nV/ $\sqrt{\text{Hz}}$ .
4. The temperature output pin on the 8-pin package versions enables the AD680 to be configured as a temperature transducer.
5. Plastic DIP packaging provides machine insertability, while SOIC packaging provides surface mount capability. TO-92 packaging offers a cost effective alternative to two-terminal references, offering a complete solution in the same package in which two-terminal references are usually found.

# AD680—SPECIFICATIONS (T<sub>A</sub> = +25°C, V<sub>IN</sub> = +5 V, unless otherwise noted)

Model	AD680AN/AR			AD680JN/JR			AD680JT			Units
	Min	Typ	Max	Min	Typ	Max	Min	Typ	Max	
OUTPUT VOLTAGE	<b>2.495</b>		<b>2.505</b>	<b>2.490</b>		<b>2.510</b>	<b>2.490</b>		<b>2.510</b>	V
OUTPUT VOLTAGE DRIFT <sup>1</sup> 0°C to +70°C -40°C to +85°C		10	20		10 25	25		10 25	30	ppm/°C
LINE REGULATION 4.5 V ≤ +V <sub>IN</sub> ≤ 15 V (@ T <sub>MIN</sub> to T <sub>MAX</sub> ) 15 V ≤ +V <sub>IN</sub> ≤ 36 V (@ T <sub>MIN</sub> to T <sub>MAX</sub> )			40 40 40 40			*			*	μV/V
LOAD REGULATION 0 < I <sub>OUT</sub> < 10 mA (@ T <sub>MIN</sub> to T <sub>MAX</sub> )		80 80	100 100		*	*		*	*	μV/mA
QUIESCENT CURRENT (@ T <sub>MIN</sub> to T <sub>MAX</sub> )		195	<b>250</b> 280		*	*		*	*	μA
POWER DISSIPATION		1	<b>1.25</b>		*	*		*	*	mW
OUTPUT NOISE 0.1 Hz to 10 Hz Spectral Density, 100 Hz		8 250	10		*	*		*	*	mV p-p nV/√Hz
CAPACITIVE LOAD			50			*			*	nF
LONG TERM STABILITY		25			*			*		ppm/1000 hr
SHORT CIRCUIT CURRENT TO GROUND		25	50		*	*		*	*	mA
TEMPERATURE PIN Voltage Output @ +25°C Temperature Sensitivity Output Current Output Resistance	540 -5	596 2 12	660 +5	*	*	*				mV mV/°C μA kΩ
TEMPERATURE RANGE Specified Performance Operating Performance <sup>2</sup>	-40 -40		+85 +85	0 -40		+70 +85	0 -40		+70 +85	°C

## NOTES

<sup>1</sup>Maximum output voltage drift is guaranteed for all packages.

<sup>2</sup>The operating temperature range is defined as the temperature extremes at which the device will still function. Parts may deviate from their specified performance outside their specified temperature range.

\*Same as AD680AN/AR specification.

Specifications subject to change without notice.

Specifications in **boldface** are tested on all production units at final electrical test. Results from those tests are used to calculate outgoing quality levels. All min and max specifications are guaranteed.

**ABSOLUTE MAXIMUM RATINGS\***

$V_{IN}$ to Ground	36 V
Power Dissipation (25°C)	500 mW
Storage Temperature	-65°C to +125°C
Lead Temperature (Soldering, 10 sec)	300°C
Package Thermal Resistance	
$\theta_{JA}$ (All Packages)	120°C/W

Output Protection: Output safe for indefinite short to ground and momentary short to  $V_{IN}$ .

\*Stresses above those listed under "Absolute Maximum Ratings" may cause permanent damage to the device. This is a stress rating only and functional operation of the device at these or any other conditions above those indicated in the operational sections of this specification is not implied. Exposure to absolute maximum rating conditions for extended periods may affect device reliability.

**8-Pin Plastic DIP  
and  
8-Pin SOIC Packages**

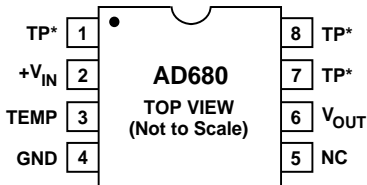

NC = NO CONNECT

\*TP DENOTES FACTORY TEST POINT. NO CONNECTIONS SHOULD BE MADE TO THESE PINS.

**TO-92 Package**

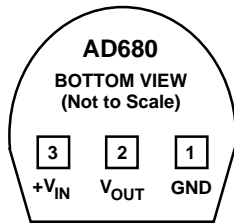

Figure 1. Connection Diagrams

**THEORY OF OPERATION**

Bandgap references are the high performance solution for low supply voltage operation. A typical precision bandgap will consist of a reference core and buffer amplifier. Based on a new, patented bandgap reference design (Figure 2), the AD680 merges the amplifier and the core bandgap function to produce a compact, complete precision reference. Central to the device is a high gain amplifier with an intentionally large Proportional To Absolute Temperature (PTAT) input offset. This offset is controlled by the area ratio of the amplifier input pair, Q1 and Q2, and is developed across resistor R1. Transistor Q12's base emitter voltage has a Complementary To Absolute Temperature (CTAT) characteristic. Resistor R2 and the parallel combination of R3 and R4 "multiply" the PTAT voltage across R1. Trimming resistors R3 and R4 to the proper ratio produces a temperature invariant 2.5 V at the output. The result is an accurate, stable output voltage accomplished with a minimum number of components.

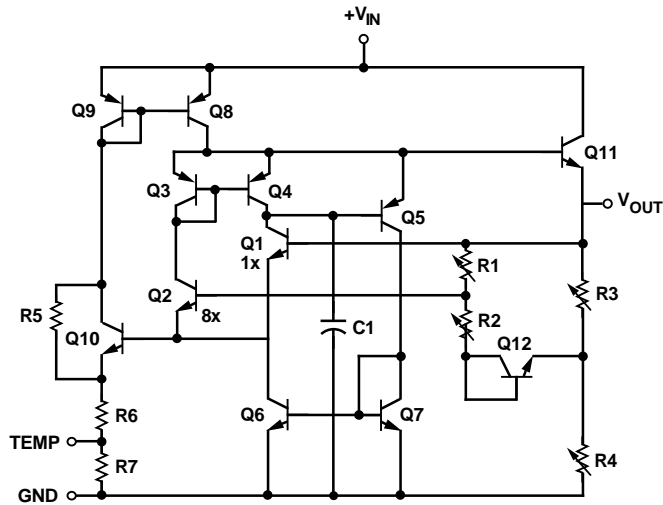

Figure 2. AD680 Schematic Diagram

An additional feature with this approach is the ability to minimize the noise while maintaining very low overall power dissipation for the entire circuit. Frequently it is difficult to independently control the dominant noise sources for bandgap references: bandgap transistor noise and resistor thermal noise. By properly choosing the operating currents of Q1 and Q2 and separately sizing R1, low wideband noise is realized while maintaining 1 mW typical power dissipation.

**ORDERING GUIDE**

Model	Initial Error mV	Temperature Coeff. ppm/°C	Temperature Range	Package Description	Package Option*
AD680JN	10	25	0°C to +70°C	Plastic	N-8
AD680JR	10	25	0°C to +70°C	SOIC	SO-8
AD680JT	10	30	0°C to +70°C	TO-92	TO-92
AD680AN	5	20	-40°C to +85°C	Plastic	N-8
AD680AR	5	20	-40°C to +85°C	SOIC	SO-8

\*N = Plastic DIP Package; SO = SOIC Package; T = TO-92 Package.

# AD680

## APPLYING THE AD680

The AD680 is simple to use in virtually all precision reference applications. When power is applied to  $+V_{IN}$  and the GND pin is tied to ground,  $V_{OUT}$  provides a +2.5 V output. The AD680 typically requires less than 250  $\mu\text{A}$  of current when operating from a supply of +4.5 V to +36 V.

To operate the AD680, the  $+V_{IN}$  pin must be bypassed to the GND pin with a 0.1  $\mu\text{F}$  capacitor tied as close to the AD680 as possible. Although the ground current for the AD680 is small (typically 195  $\mu\text{A}$ ), a direct connection should be made between the AD680 GND pin and the system ground plane.

Reference outputs are frequently required to handle fast transients caused by input switching networks, as are commonly found in ADCs and measurement instrumentation equipment. Many of the dynamic problems associated with this situation can be minimized with a few simple techniques. Using a series resistor between the reference output and the load will tend to “decouple” the reference output from the transient source. Or a relatively large capacitor connected from the reference output to ground can serve as a charge storage element to absorb and deliver charge as is required by the dynamic load. A 50 nF capacitor is recommended for the AD680 in this case; this is large enough to store the required charge, but small enough so as not to disrupt the stability of the reference.

The 8-pin plastic DIP and SOIC packaged versions of the AD680 also provide a temperature output pin. The voltage on this pin is nominally 596 mV at 25°C. This pin will provide an output linearly proportional to temperature with a characteristic of 2 mV/°C.

## NOISE PERFORMANCE

The noise generated by the AD680 is typically less than 8  $\mu\text{V}$  p-p over the 0.1 Hz to 10 Hz band. Figure 3 shows the 0.1 Hz to 10 Hz noise of a typical AD680. The noise measurement is made with a bandpass filter made of a 1-pole high-pass filter with a corner frequency at 0.1 Hz and a 2-pole low-pass filter with a corner frequency at 12.6 Hz to create a filter with a 9.922 Hz bandwidth.

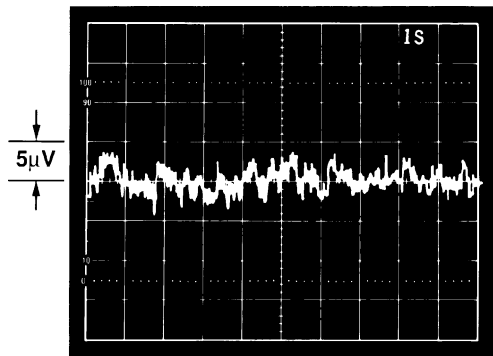

Figure 3. 0.1 Hz to 10 Hz Noise

Noise in a 300 kHz bandwidth is approximately 800  $\mu\text{V}$  p-p. Figure 4 shows the broadband noise of a typical AD680.

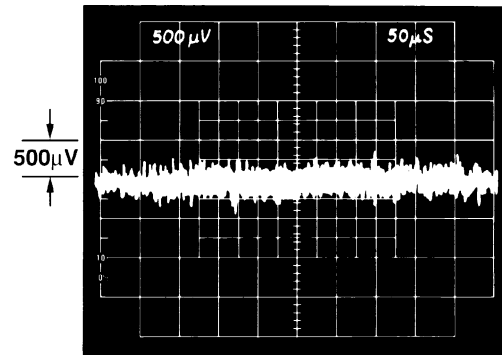

Figure 4. Broadband Noise at 300 kHz

## TURN-ON TIME

Upon application of power (cold start), the time required for the output voltage to reach its final value within a specified error band is defined as the turn-on settling time. Two components normally associated with this are: the time for the active circuits to settle, and the time for the thermal gradients on the chip to stabilize. Figure 5 shows the turn-on settling time of the AD680 to be about 20  $\mu\text{s}$  to 0.025% of its final value.

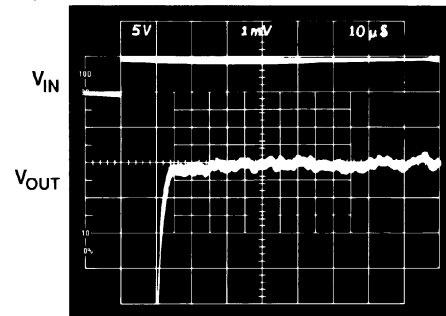

Figure 5. Turn-On Settling Time

The AD680 thermal settling characteristic benefits from its compact design. Once initial turn-on is achieved, the output linearly approaches its final value; the output is typically within 0.01% of its final value after 25 ms.

## DYNAMIC PERFORMANCE

The output stage of the amplifier is designed to provide the AD680 with static and dynamic load regulation superior to less complete references.

Figure 6 displays the characteristics of the AD680 output amplifier driving a 0 mA to 10 mA load. Longer settling times will result if the reference is forced to sink any transient current.

In some applications, a varying load may be both resistive and capacitive in nature, or the load may be connected to the AD680 by a long capacitive cable.

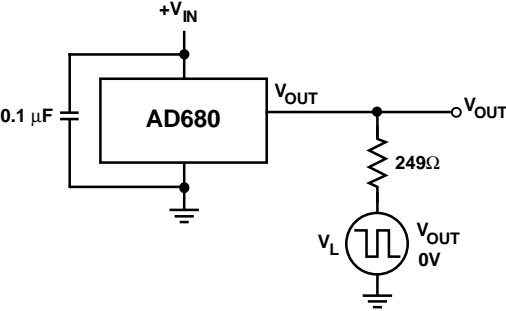

Figure 6a. Transient Load Test Circuit

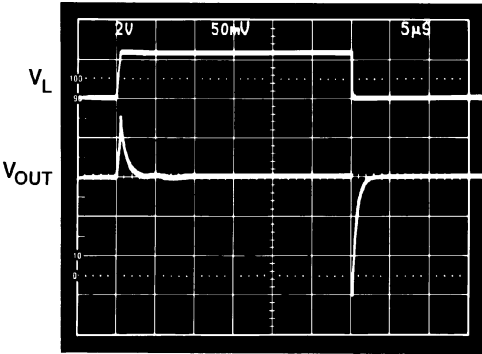

Figure 6b. Large-Scale Transient Response

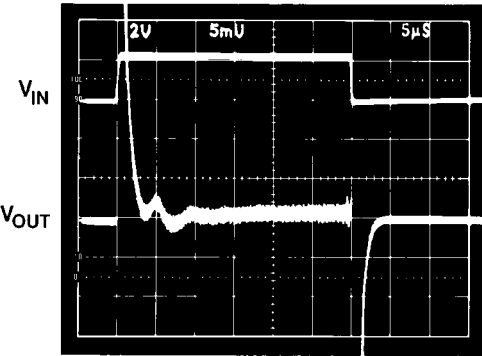

Figure 6c. Fine Scale Settling for Transient Load

Figure 7 displays the output amplifier characteristics driving a 1000 pF, 0 mA to 10 mA load.

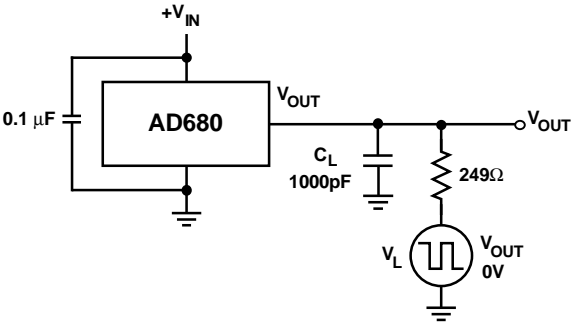

Figure 7a. Capacitive Load Transient Response Test Circuit

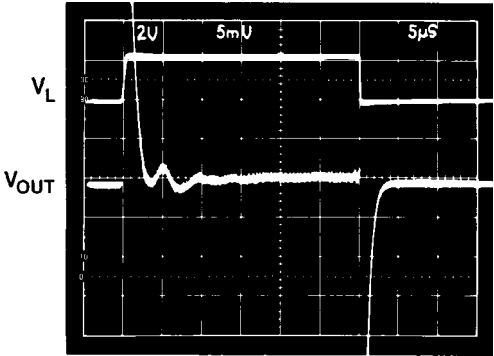

Figure 7b. Output Response with Capacitive Load

**LOAD REGULATION**

Figure 8 shows the load regulation characteristics of the AD680.

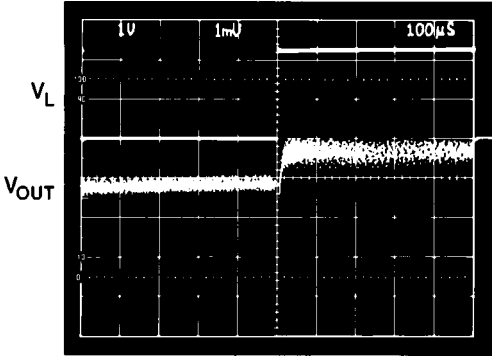

Figure 8. Typical Load Regulation Characteristics

# AD680

## TEMPERATURE PERFORMANCE

The AD680 is designed for reference applications where temperature performance is important. Extensive temperature testing and characterization ensures that the device's performance is maintained over the specified temperature range.

Some confusion exists in the area of defining and specifying reference voltage error over temperature. Historically, references have been characterized using a maximum deviation per degree centigrade, i.e., ppm/°C. However, because of nonlinearities in temperature characteristics which originated in standard Zener references (such as "S" type characteristics), most manufacturers now use a maximum limit error band approach to specify devices. This technique involves the measurement of the output at three or more different temperatures to specify an output voltage error band.

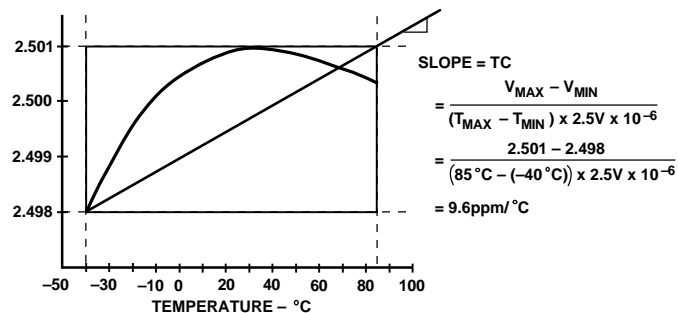

Figure 9. Typical AD680AN/AP Temperature Drift

Figure 9 shows a typical output voltage drift for the AD680AN/AR and illustrates the test methodology. The box in Figure 9 is bounded on the sides by the operating temperature extremes, and on the top and bottom by the maximum and minimum output voltages measured over the operating temperature range.

The maximum height of the box for the appropriate temperature range and device grade is shown in Table I. Duplication of these results requires a combination of high accuracy and stable temperature control in a test system. Evaluation of the AD680 will produce a curve similar to that in Figure 9, but output readings may vary depending upon the test equipment utilized.

## TEMPERATURE OUTPUT PIN

The 8-pin packaged versions of the AD680 provide a temperature output pin on Pin 3 of each device. The output of Pin 3 (TEMP) is a voltage that varies linearly with temperature.  $V_{TEMP}$  at 25°C is 596 mV, and the temperature coefficient is 2 mV/°C. Figure 10 shows the output of this pin over temperature.

The temperature pin has an output resistance of 12 kΩ and is capable of sinking or sourcing currents of up to 5 μA without disturbing the reference output, enabling the temp pin to be buffered by any of a number of inexpensive operational amplifiers that have bias currents below this value.

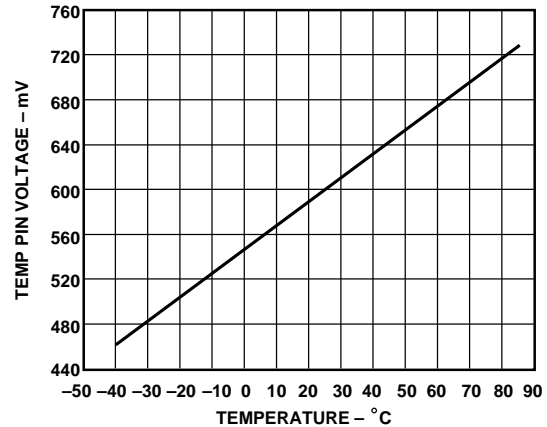

Figure 10. Temp Pin Transfer Characteristic

## DIFFERENTIAL TEMPERATURE TRANSDUCER

Figure 11 shows a differential temperature transducer that can be used to measure temperature changes in the AD680's environment. This circuit operates from a +5 V supply. The temperature dependent voltage from the TEMP pin of the AD680 is amplified by a factor of 5 to provide wider full-scale range and more current sourcing capability. An exact gain of 5 can be achieved by adjusting the trim potentiometer until the output varies by 10 mV/°C. To minimize resistance changes with temperature, resistors with low temperature coefficients, such as metal film resistors, should be used.

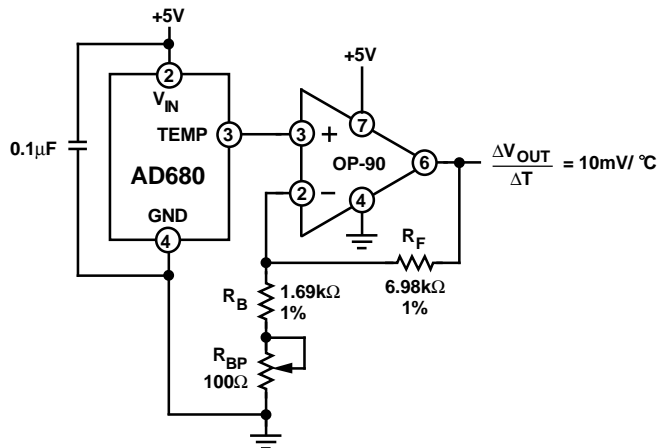

Figure 11. Differential Temperature Transducer

## LOW POWER, LOW VOLTAGE REFERENCE FOR DATA CONVERTERS

The AD680 has a number of features that make it ideally suited for use with A/D and D/A converters. The low supply voltage required makes it possible to use the AD680 with today's converters that run on 5 V supplies without having to add a higher supply voltage for the reference. The low quiescent current (195 μA), combined with the completeness and accuracy of the AD680 make it ideal for low power applications such as handheld, battery operated meters.

One such ADC that the AD680 is well suited for is the AD7701. Figure 12a shows the AD680 used as the reference for this converter. The AD7701 is a 16-bit A/D converter with on-chip digital filtering intended for the measurement of wide dynamic range, low frequency signals such as those representing chemical, physical or biological processes. It contains a charge balancing (sigma-delta) ADC, calibration microcontroller with on-chip static RAM, a clock oscillator and a serial communications port.

This entire circuit runs on  $\pm 5$  V supplies. The power dissipation of the AD7701 is typically 25 mW and, when combined with the power dissipation of the AD680 (1 mW), the entire circuit consumes just 26 mW of power.

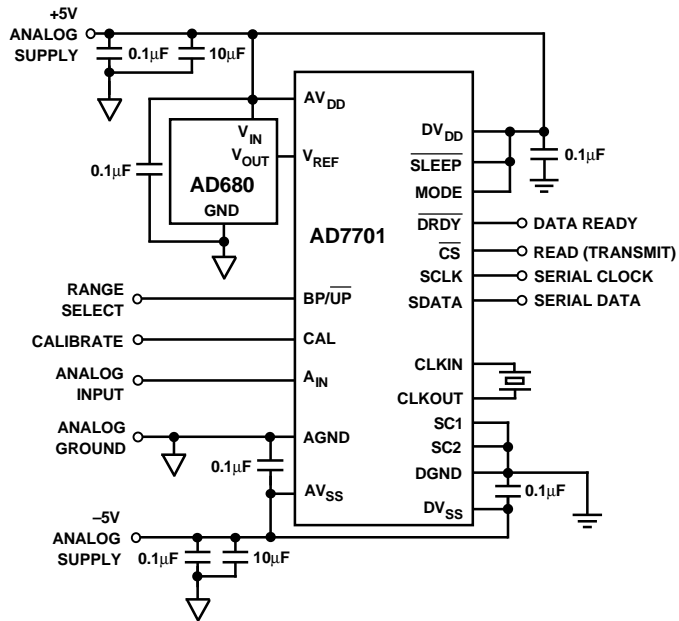

Figure 12a. Low Power, Low Voltage Supply Reference for the AD7701 16-Bit A/D Converter

Figure 12b shows the AD680 connected to the AD773 high speed 8-bit ADC. The low pass filter shown minimizes the AD680's wideband noise.

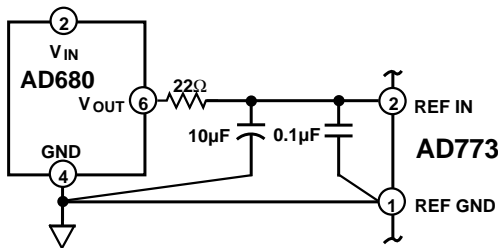

Figure 12b. AD680 to AD773 Connection

The AD773's high impedance reference input allows direct connection to the AD680. Unlike the resistor ladder requirements of a flash converter the AD773's single pin, high impedance input can be driven from one low cost, low power reference. The high impedance input allows multiple AD773's to be driven from one AD680 thus minimizing drift errors.

**+4.5 V REFERENCE FROM A +5 V SUPPLY**

The AD680 can be used to provide a low power, +4.5 V reference as shown in Figure 13. In addition to the AD680, the circuit uses a low power op amp and a transistor in a feedback configuration that provides a regulated +4.5 V output for a power supply voltage as low as +4.7 V. The high quality tantalum 10 µF capacitor (C1) in parallel with the ceramic 0.1 µF capacitor (C2) and the 3.9 Ω resistor (R5) ensure a low output impedance up to around 50 MHz.

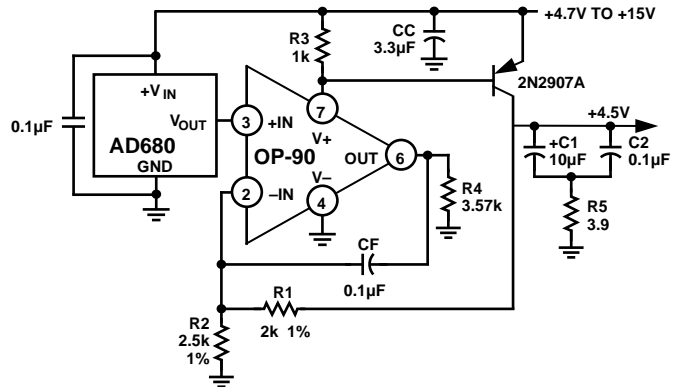

Figure 13. +4.5 V Reference Running from a Single +5 V Supply

**VOLTAGE REGULATOR FOR PORTABLE EQUIPMENT**

The AD680 is ideal for providing a stable, low cost and low power reference voltage in portable equipment power supplies. Figure 14 shows how the AD680 can be used in a voltage regulator that not only has low output noise (as compared to a switchmode design) and low power, but also a very fast recovery after current surges. Some precaution should be taken in the selection of the output capacitors. Too high an ESR (effective series resistance) could endanger the stability of the circuit. A solid tantalum capacitor, 16 V or higher, and an aluminum electrolytic capacitor, 10 V or higher, are recommended for C1 and C2, respectively. Also, the path from the ground side of C1 and C2 to the ground side of R1 should be kept as short as possible.

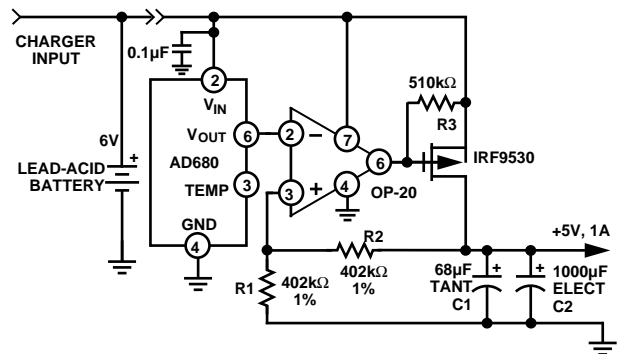
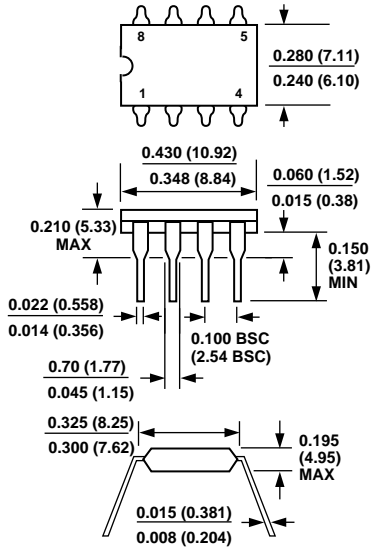

Figure 14. Voltage Regulator for Portable Equipment

**OUTLINE DIMENSIONS**

Dimensions shown in inches and (mm).

**8-Pin Plastic DIP**



**8-Pin SOIC**

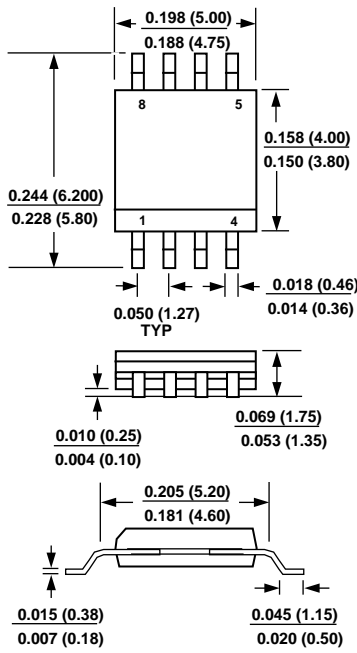

**3-Pin TO-92**

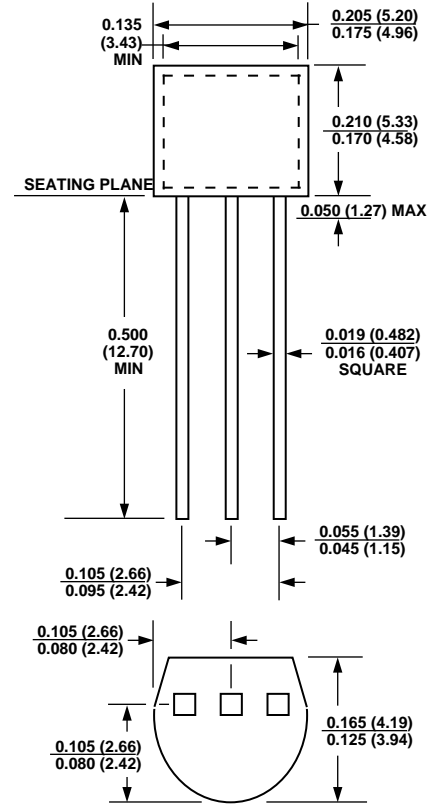

C1503a-5-9/93

PRINTED IN U.S.A.