

## Locknuts DIN 70852

**Material:** Steel, hardness class 17H  
 Steel, zinc-plated, hardness class 17H.  
 Stainless steel 1.4301 (AISI 304).



These nuts are used for unsafe, quickly to loosen applications, or for a secured connection with an additional lock plate DIN 70952 (for these lockwashers, a keyway is required on the shaft thread).

Recommend tolerance for the shaft thread: 6g DIN ISO 965.

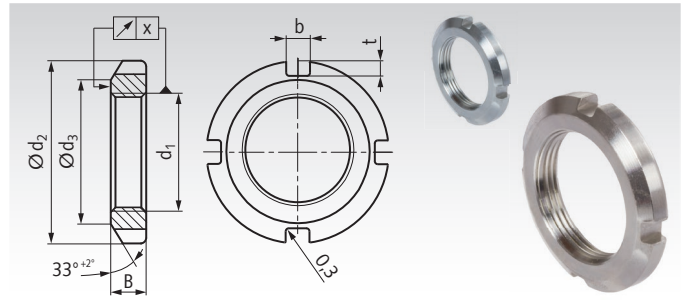

Ordering Details: e.g.: Product No. 65350100, Locknut DIN 70852, Steel, M10x1

Product No. steel	Product No. zinc-plated	Product No. stainless	$d_1$ mm	$d_2^{h12}$ mm	$d_3$ mm	$B^{h11}$ mm	$b$ mm	$t_{min.}$ mm	$x$ mm	Number of slots	Weight g
653 501 00	653 885 01	653 995 01	M10 x 1	20	16	5	4,5	1,8	0,04	4	7
653 502 00	653 885 02	653 995 02	M12 x 1,5	22	18	6	4,5	1,8	0,04	4	10
653 503 00	653 885 03	653 995 03	M14 x 1,5	24	20	6	4,5	1,8	0,04	4	11
653 504 00	653 885 04	653 995 04	M16 x 1,5	28	23	6	5,5	2,3	0,04	4	16
653 505 00	653 885 05	653 995 05	M18 x 1,5	30	25	6	5,5	2,3	0,04	4	17
653 506 00	653 885 06	653 995 06	M20 x 1,5	32	27	6	5,5	2,3	0,04	4	19
653 507 00	653 885 07	653 995 07	M22 x 1,5	36	30	7	6,5	2,8	0,04	4	28
653 508 00	653 885 08	653 995 08	M24 x 1,5	38	32	7	6,5	2,8	0,04	4	30
653 509 00	653 885 09	653 995 09	M26 x 1,5	40	34	7	6,5	2,8	0,04	4	32
653 510 00	653 885 10	653 995 10	M28 x 1,5	42	36	7	6,5	2,8	0,04	4	35
653 511 00	653 885 11	653 995 11	M30 x 1,5	44	38	7	6,5	2,8	0,04	4	37
653 512 00	653 885 12	653 995 12	M32 x 1,5	48	41	8	7	3,3	0,04	4	52
653 513 00	653 885 13	653 995 13	M35 x 1,5	50	43	8	7	3,3	0,04	4	51
653 514 00	653 885 14	653 995 14	M38 x 1,5	54	47	8	7	3,3	0,04	4	60
653 515 00	653 885 15	653 995 15	M40 x 1,5	56	49	8	7	3,3	0,04	4	63
653 516 00	653 885 16	653 995 16	M42 x 1,5	60	52	8	8	3,8	0,04	4	75
653 517 00	653 885 17	653 995 17	M45 x 1,5	62	54	8	8	3,8	0,04	6	70
653 518 00	653 885 18	653 995 18	M48 x 1,5	65	57	8	8	3,8	0,04	6	75
653 519 00	653 885 19	653 995 19	M50 x 1,5	68	60	8	8	3,8	0,04	6	84
653 520 00	653 885 20	653 995 20	M52 x 1,5	70	62	8	8	3,8	0,05	6	88
653 521 00	653 885 21	653 995 21	M55 x 1,5	75	67	8	8	3,8	0,05	6	106
653 522 00	653 885 22	653 995 22	M60 x 1,5	80	71	9	11	4,3	0,05	6	123
653 523 00	653 885 23	653 995 23	M65 x 1,5	85	76	9	11	4,3	0,05	6	132
653 524 00	653 885 24	653 995 24	M70 x 1,5	90	81	9	11	4,3	0,05	6	142
653 525 00	653 885 25	653 995 25	M75 x 1,5	95	86	10	11	4,3	0,05	6	169
653 526 00	653 885 26	653 995 26	M80 x 1,5	100	91	10	11	4,3	0,05	6	180
653 527 00	653 885 27	653 995 27	M85 x 1,5	108	99	10	11	4,3	0,05	6	230
653 528 00	653 885 28	653 995 28	M90 x 1,5	112	103	10	11	4,3	0,05	6	229
653 529 00	653 885 29	653 995 29	M95 x 1,5	118	109	10	11	4,3	0,05	6	256
653 500 00	653 885 00	653 995 00	M100 x 1,5	125	116	10	11	4,3	0,05	6	299

## Hook Wrenches DIN 1810 form A for Locknuts

**Material:** High grade tool steel, black oxide finish.

Hook wrenches for locknuts DIN 981, slotted nuts DIN 1804 and other products.

**Please note:** For some applications like mounting the precision levelling adjusters, there are two wrenches required.

Ordering Details: e.g.: Product No. 65340012, Hook Wrench 12-14 mm



Product No.	$D_m$ Range mm	Length mm	Thickness mm	Weight g
653 400 12	12 - 14	110	3	25
653 400 16	16 - 20	110	3	25
653 400 25	25 - 28	136	4	45
653 400 30	30 - 32	136	4	50
653 400 34	34 - 36	170	5	90
653 400 38	38 - 45	170	5	95
653 400 40	40 - 42	170	5	90
653 400 45	45 - 50	206	6	155
653 400 52	52 - 55	206	6	160
653 400 58	58 - 62	240	7	260
653 400 68	68 - 75	240	7	255
653 400 80	80 - 90	280	8	410
653 400 95	95 - 100	280	8	405
653 401 10	110 - 115	335	10	745
653 401 20	120 - 130	335	10	720
653 401 35	135 - 145	385	10	1000