

Series MXQ

Dimensions: MXQ8L/Symmetric Type

* For detailed dimensions about the stroke adjuster, refer to the option for the stroke adjuster.
Rubber stopper (Refer to page 122.)
Metal stopper (Refer to page 125.)

Basic style

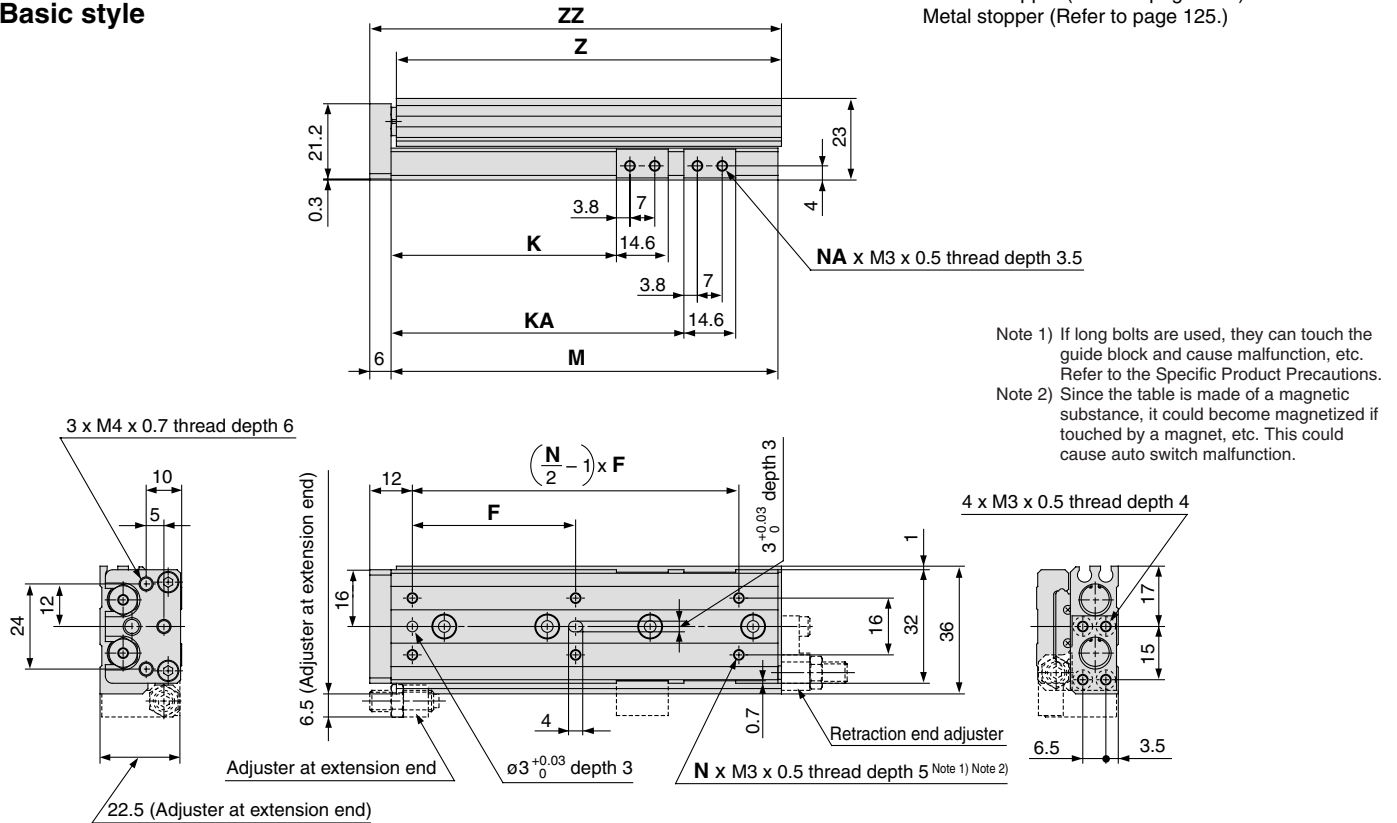

Bottom view of MXQ8L-30

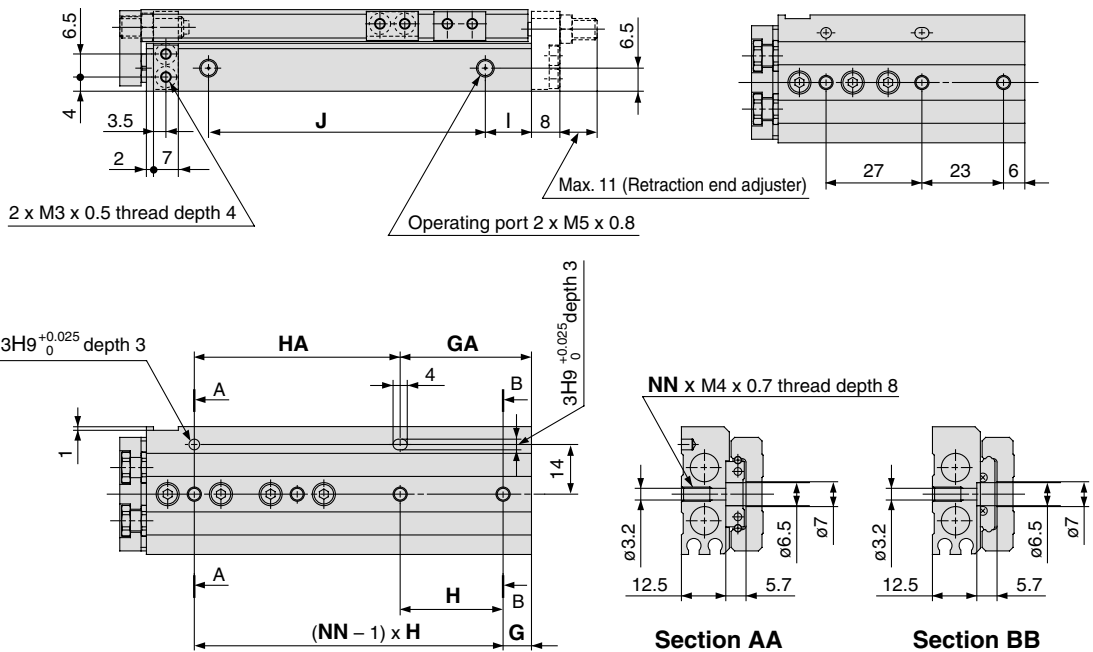

Model	F	N	G	H	NN	GA	HA	I	J	K	KA	NA	M	Z	ZZ
MXQ8L-10	25	4	7	25	2	13	19	11	17	23.5	—	4	46	45.5	53
MXQ8L-20	25	4	14	28	2	14	28	10	28	33.5	—	4	56	55.5	63
MXQ8L-30	26	6	Note)	Note)	3	29	27	12	40	43.5	—	4	70	69.5	77
MXQ8L-40	32	6	8	31	3	39	31	14	52	53.5	—	4	84	83.5	91
MXQ8L-50	46	6	8	29	4	37	58	13	78	63.5	82.5	8	109	108.5	116
MXQ8L-75	50	6	31	30	4	61	60	12	105	88.5	112.5	8	135	134.5	142

Note) Refer to the bottom view of MXQ8L-30.