

Rändelräder, Stahlteile aus Edelstahl, Form L, mit Außengewinde

Artikelbeschreibung/Produktabbildungen

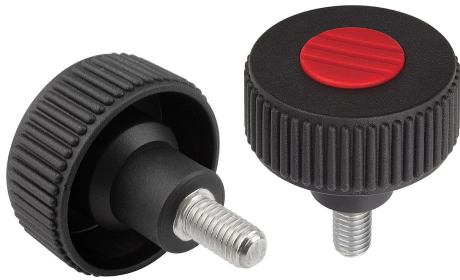

Beschreibung

Werkstoff:

Thermoplast schwarzgrau.

Gewindebolzen aus Edelstahl 1.4305.

Ausführung:

Gewindebolzen blank.

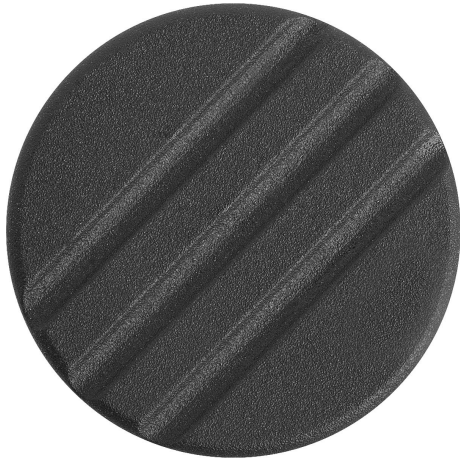



Rändelräder, Stahlteile aus Edelstahl, Form L, mit Außengewinde

Artikelbeschreibung/Produktabbildungen



Zeichnungen

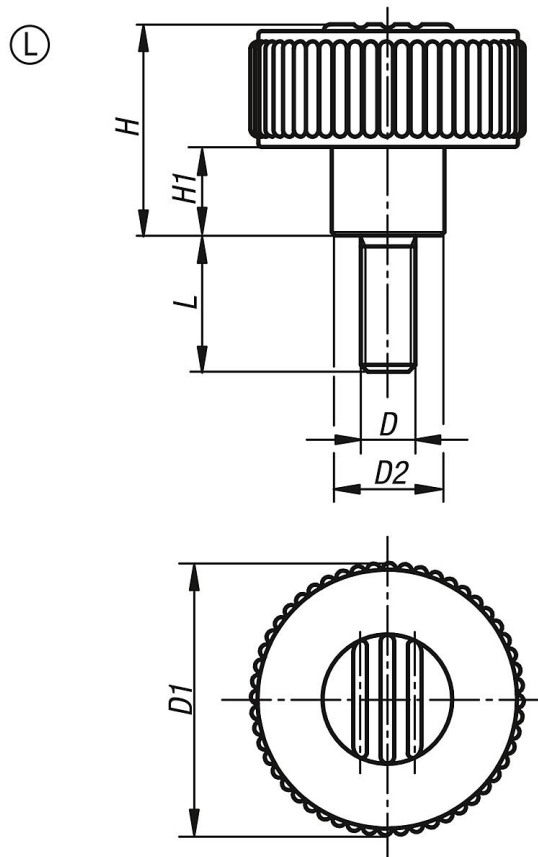

Artikelübersicht

Rändelräder, Stahlteile aus Edelstahl, Form L, mit Außengewinde

Bestellnummer	Form	Farbe Deckel	Größe	D	D1	D2	H	H1	L
K0261.5105X10	L	schwarzgrau RAL 7021	1	M5	40	16,5	31	13	10
K0261.51051X10	L	reinorange RAL 2004	1	M5	40	16,5	31	13	10
K0261.51052X10	L	signalgrün RAL 6032	1	M5	40	16,5	31	13	10
K0261.51053X10	L	verkehrsblau RAL 5017	1	M5	40	16,5	31	13	10

Rändelräder, Stahlteile aus Edelstahl, Form L, mit Außengewinde

Artikelübersicht

Bestellnummer	Form	Farbe Deckel	Größe	D	D1	D2	H	H1	L
K0261.51055X10	L	lichtgrau RAL 7035	1	M5	40	16,5	31	13	10
K0261.51056X10	L	verkehrsrot RAL 3020	1	M5	40	16,5	31	13	10
K0261.51057X10	L	rapsgelb RAL 1021	1	M5	40	16,5	31	13	10
K0261.5105X20	L	schwarzgrau RAL 7021	1	M5	40	16,5	31	13	20
K0261.51051X20	L	reinorange RAL 2004	1	M5	40	16,5	31	13	20
K0261.51052X20	L	signalgrün RAL 6032	1	M5	40	16,5	31	13	20
K0261.51053X20	L	verkehrsblau RAL 5017	1	M5	40	16,5	31	13	20
K0261.51055X20	L	lichtgrau RAL 7035	1	M5	40	16,5	31	13	20
K0261.51056X20	L	verkehrsrot RAL 3020	1	M5	40	16,5	31	13	20
K0261.51057X20	L	rapsgelb RAL 1021	1	M5	40	16,5	31	13	20
K0261.5106X10	L	schwarzgrau RAL 7021	1	M6	40	16,5	31	13	10
K0261.51061X10	L	reinorange RAL 2004	1	M6	40	16,5	31	13	10
K0261.51062X10	L	signalgrün RAL 6032	1	M6	40	16,5	31	13	10
K0261.51063X10	L	verkehrsblau RAL 5017	1	M6	40	16,5	31	13	10
K0261.51065X10	L	lichtgrau RAL 7035	1	M6	40	16,5	31	13	10
K0261.51066X10	L	verkehrsrot RAL 3020	1	M6	40	16,5	31	13	10
K0261.51067X10	L	rapsgelb RAL 1021	1	M6	40	16,5	31	13	10
K0261.5106X20	L	schwarzgrau RAL 7021	1	M6	40	16,5	31	13	20
K0261.51061X20	L	reinorange RAL 2004	1	M6	40	16,5	31	13	20
K0261.51062X20	L	signalgrün RAL 6032	1	M6	40	16,5	31	13	20
K0261.51063X20	L	verkehrsblau RAL 5017	1	M6	40	16,5	31	13	20
K0261.51065X20	L	lichtgrau RAL 7035	1	M6	40	16,5	31	13	20
K0261.51066X20	L	verkehrsrot RAL 3020	1	M6	40	16,5	31	13	20
K0261.51067X20	L	rapsgelb RAL 1021	1	M6	40	16,5	31	13	20
K0261.5106X40	L	schwarzgrau RAL 7021	1	M6	40	16,5	31	13	40
K0261.51061X40	L	reinorange RAL 2004	1	M6	40	16,5	31	13	40
K0261.51062X40	L	signalgrün RAL 6032	1	M6	40	16,5	31	13	40
K0261.51063X40	L	verkehrsblau RAL 5017	1	M6	40	16,5	31	13	40
K0261.51065X40	L	lichtgrau RAL 7035	1	M6	40	16,5	31	13	40
K0261.51066X40	L	verkehrsrot RAL 3020	1	M6	40	16,5	31	13	40
K0261.51067X40	L	rapsgelb RAL 1021	1	M6	40	16,5	31	13	40
K0261.5108X15	L	schwarzgrau RAL 7021	1	M8	40	16,5	31	13	15
K0261.51081X15	L	reinorange RAL 2004	1	M8	40	16,5	31	13	15
K0261.51082X15	L	signalgrün RAL 6032	1	M8	40	16,5	31	13	15
K0261.51083X15	L	verkehrsblau RAL 5017	1	M8	40	16,5	31	13	15
K0261.51085X15	L	lichtgrau RAL 7035	1	M8	40	16,5	31	13	15
K0261.51086X15	L	verkehrsrot RAL 3020	1	M8	40	16,5	31	13	15
K0261.51087X15	L	rapsgelb RAL 1021	1	M8	40	16,5	31	13	15
K0261.5108X30	L	schwarzgrau RAL 7021	1	M8	40	16,5	31	13	30
K0261.51081X30	L	reinorange RAL 2004	1	M8	40	16,5	31	13	30
K0261.51082X30	L	signalgrün RAL 6032	1	M8	40	16,5	31	13	30
K0261.51083X30	L	verkehrsblau RAL 5017	1	M8	40	16,5	31	13	30
K0261.51085X30	L	lichtgrau RAL 7035	1	M8	40	16,5	31	13	30
K0261.51086X30	L	verkehrsrot RAL 3020	1	M8	40	16,5	31	13	30
K0261.51087X30	L	rapsgelb RAL 1021	1	M8	40	16,5	31	13	30
K0261.5108X60	L	schwarzgrau RAL 7021	1	M8	40	16,5	31	13	60
K0261.51081X60	L	reinorange RAL 2004	1	M8	40	16,5	31	13	60
K0261.51082X60	L	signalgrün RAL 6032	1	M8	40	16,5	31	13	60
K0261.51083X60	L	verkehrsblau RAL 5017	1	M8	40	16,5	31	13	60
K0261.51085X60	L	lichtgrau RAL 7035	1	M8	40	16,5	31	13	60
K0261.51086X60	L	verkehrsrot RAL 3020	1	M8	40	16,5	31	13	60
K0261.51087X60	L	rapsgelb RAL 1021	1	M8	40	16,5	31	13	60
K0261.5208X15	L	schwarzgrau RAL 7021	2	M8	50	18	36	15	15
K0261.52081X15	L	reinorange RAL 2004	2	M8	50	18	36	15	15
K0261.52082X15	L	signalgrün RAL 6032	2	M8	50	18	36	15	15
K0261.52083X15	L	verkehrsblau RAL 5017	2	M8	50	18	36	15	15
K0261.52085X15	L	lichtgrau RAL 7035	2	M8	50	18	36	15	15
K0261.52086X15	L	verkehrsrot RAL 3020	2	M8	50	18	36	15	15
K0261.52087X15	L	rapsgelb RAL 1021	2	M8	50	18	36	15	15
K0261.5208X30	L	schwarzgrau RAL 7021	2	M8	50	18	36	15	30
K0261.52081X30	L	reinorange RAL 2004	2	M8	50	18	36	15	30
K0261.52082X30	L	signalgrün RAL 6032	2	M8	50	18	36	15	30

Rändelräder, Stahlteile aus Edelstahl, Form L, mit Außengewinde

Artikelübersicht

Bestellnummer	Form	Farbe Deckel	Größe	D	D1	D2	H	H1	L
K0261.52083X30	L	verkehrsblau RAL 5017	2	M8	50	18	36	15	30
K0261.52085X30	L	lichtgrau RAL 7035	2	M8	50	18	36	15	30
K0261.52086X30	L	verkehrsrot RAL 3020	2	M8	50	18	36	15	30
K0261.52087X30	L	rapsgelb RAL 1021	2	M8	50	18	36	15	30
K0261.5208X60	L	schwarzgrau RAL 7021	2	M8	50	18	36	15	60
K0261.52081X60	L	reinorange RAL 2004	2	M8	50	18	36	15	60
K0261.52082X60	L	signalgrün RAL 6032	2	M8	50	18	36	15	60
K0261.52083X60	L	verkehrsblau RAL 5017	2	M8	50	18	36	15	60
K0261.52085X60	L	lichtgrau RAL 7035	2	M8	50	18	36	15	60
K0261.52086X60	L	verkehrsrot RAL 3020	2	M8	50	18	36	15	60
K0261.52087X60	L	rapsgelb RAL 1021	2	M8	50	18	36	15	60
K0261.5210X20	L	schwarzgrau RAL 7021	2	M10	50	18	36	15	20
K0261.52101X20	L	reinorange RAL 2004	2	M10	50	18	36	15	20
K0261.52102X20	L	signalgrün RAL 6032	2	M10	50	18	36	15	20
K0261.52103X20	L	verkehrsblau RAL 5017	2	M10	50	18	36	15	20
K0261.52105X20	L	lichtgrau RAL 7035	2	M10	50	18	36	15	20
K0261.52106X20	L	verkehrsrot RAL 3020	2	M10	50	18	36	15	20
K0261.52107X20	L	rapsgelb RAL 1021	2	M10	50	18	36	15	20
K0261.5210X30	L	schwarzgrau RAL 7021	2	M10	50	18	36	15	30
K0261.52101X30	L	reinorange RAL 2004	2	M10	50	18	36	15	30
K0261.52102X30	L	signalgrün RAL 6032	2	M10	50	18	36	15	30
K0261.52103X30	L	verkehrsblau RAL 5017	2	M10	50	18	36	15	30
K0261.52105X30	L	lichtgrau RAL 7035	2	M10	50	18	36	15	30
K0261.52106X30	L	verkehrsrot RAL 3020	2	M10	50	18	36	15	30
K0261.52107X30	L	rapsgelb RAL 1021	2	M10	50	18	36	15	30
K0261.5210X60	L	schwarzgrau RAL 7021	2	M10	50	18	36	15	60
K0261.52101X60	L	reinorange RAL 2004	2	M10	50	18	36	15	60
K0261.52102X60	L	signalgrün RAL 6032	2	M10	50	18	36	15	60
K0261.52103X60	L	verkehrsblau RAL 5017	2	M10	50	18	36	15	60
K0261.52105X60	L	lichtgrau RAL 7035	2	M10	50	18	36	15	60
K0261.52106X60	L	verkehrsrot RAL 3020	2	M10	50	18	36	15	60
K0261.52107X60	L	rapsgelb RAL 1021	2	M10	50	18	36	15	60
K0261.5310X20	L	schwarzgrau RAL 7021	3	M10	63	22	41	17	20
K0261.53101X20	L	reinorange RAL 2004	3	M10	63	22	41	17	20
K0261.53102X20	L	signalgrün RAL 6032	3	M10	63	22	41	17	20
K0261.53103X20	L	verkehrsblau RAL 5017	3	M10	63	22	41	17	20
K0261.53105X20	L	lichtgrau RAL 7035	3	M10	63	22	41	17	20
K0261.53106X20	L	verkehrsrot RAL 3020	3	M10	63	22	41	17	20
K0261.53107X20	L	rapsgelb RAL 1021	3	M10	63	22	41	17	20
K0261.5310X30	L	schwarzgrau RAL 7021	3	M10	63	22	41	17	30
K0261.53101X30	L	reinorange RAL 2004	3	M10	63	22	41	17	30
K0261.53102X30	L	signalgrün RAL 6032	3	M10	63	22	41	17	30
K0261.53103X30	L	verkehrsblau RAL 5017	3	M10	63	22	41	17	30
K0261.53105X30	L	lichtgrau RAL 7035	3	M10	63	22	41	17	30
K0261.53106X30	L	verkehrsrot RAL 3020	3	M10	63	22	41	17	30
K0261.53107X30	L	rapsgelb RAL 1021	3	M10	63	22	41	17	30
K0261.5310X60	L	schwarzgrau RAL 7021	3	M10	63	22	41	17	60
K0261.53101X60	L	reinorange RAL 2004	3	M10	63	22	41	17	60
K0261.53102X60	L	signalgrün RAL 6032	3	M10	63	22	41	17	60
K0261.53103X60	L	verkehrsblau RAL 5017	3	M10	63	22	41	17	60
K0261.53105X60	L	lichtgrau RAL 7035	3	M10	63	22	41	17	60
K0261.53106X60	L	verkehrsrot RAL 3020	3	M10	63	22	41	17	60
K0261.53107X60	L	rapsgelb RAL 1021	3	M10	63	22	41	17	60