



Model Number

OMH-LGS-01

Attachment aid for light grid series LGS/
LGM

Features

- Mounting bracket
- Simple and fast mounting

Accessories

OMH-SLCT-01

Quick clamp and adjustment system

Dimensions

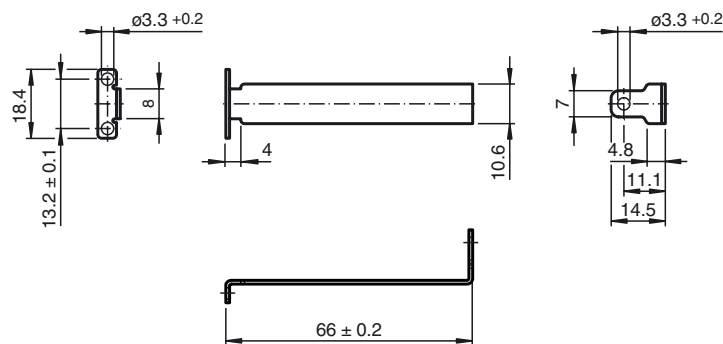

Technical data

Mechanical specifications

Material	Stainless steel
Mass	approx. 12 g
Mounting	Mounting accessories included

Suitable series

Safety Series	LGS
---------------	-----

Mechanical arrangement

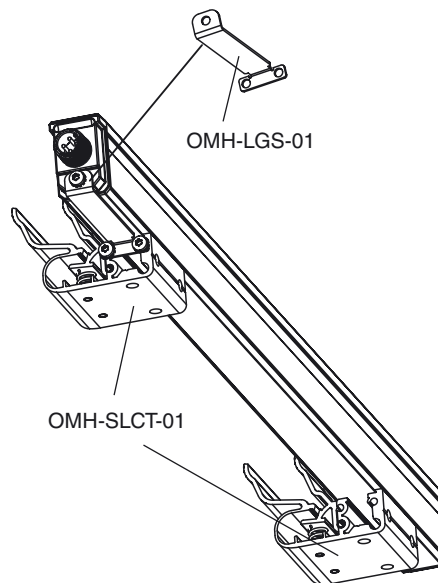

Release date: 2011-07-04 10:35 Date of issue: 2012-11-08 239518_eng.xml

Subject to modifications without notice

Pepperl+Fuchs Group
www.pepperl-fuchs.com

USA: +1 330 486 0001
fa-info@us.pepperl-fuchs.com

Germany: +49 621 776-4411
fa-info@pepperl-fuchs.com

Copyright Pepperl+Fuchs
Singapore: +65 6779 9091
fa-info@sg.pepperl-fuchs.com