

**MagI<sup>3</sup>C** Power Module Product Family  
**VDRM - Variable Step Down Regulator Module**



**A INTRODUCTION**

The MagI<sup>3</sup>C Power Module evaluation board is an ease of use DC/DC solution with an integrated inductor in the Module. This device has exceptional power conversion efficiency and good output voltage accuracy, while maintaining line and load regulation. The MagI<sup>3</sup>C Power Module is available in an innovative package that enhances thermal performance and allows for hand or machine soldering.

The MagI<sup>3</sup>C Power Module evaluation board offers a very compact and accurate solution to achieve from 0.8V to 6V output voltage and 2A continuous output current from an input voltage rail of 6V to 42V. The nearly constant switching frequency is based on a control structure which is a constant on-time with input voltage feed forward.

There is also the facility to set up a programmable UVLO of the input supply. Ceramic capacitors with low ESR assist the control loop to work nicely.

Parallel to the feedback resistor  $R_{FBT}$  is a feed forward capacitor which is selected to facilitate an optimum transient response. An external soft-start capacitor allows to control the startup rising time. The MagI<sup>3</sup>C Power Module also has on-board protection circuitry to guard against thermal and electrical damage. Thermal shut-down, over-current, overvoltage and under-voltage protections safeguard the regulator. It also includes a short-circuit protection and will start up into a pre-biased output.

**B BOARD FEATURES**

- $V_{IN} = 6V$  to  $42V$
- $V_{OUT} = 0.8V$  to  $6V$
- $I_{OUT} = 0$  to  $2A$
- PCB design 2 Layer; each  $70\mu m$
- Dimensions:  $8cm \times 8cm$
- Maximum Ambient Temperature:  $70^{\circ}C$

**C BASIC BOARD CIRCUIT**

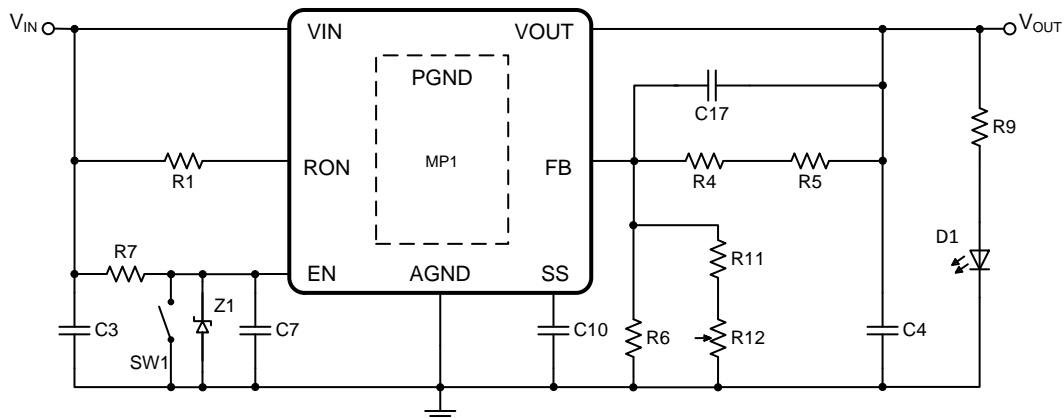

20S

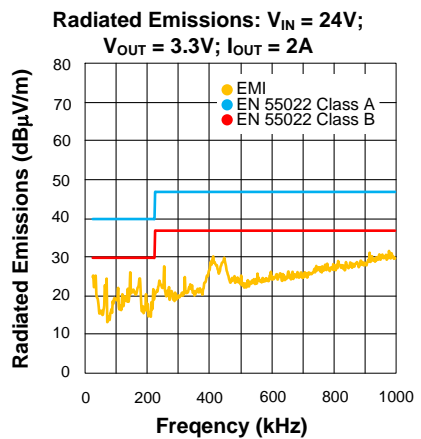

40D

AN 178020601/WPMDH1200601JEV

**MagI<sup>3</sup>C** Power Module Product Family  
**VDRM** - Variable Step Down Regulator Module



## C1 Bill of Materials for the Board Schematic

PART	POSITION	MANUFACTURER	ORDER CODE	ASSEMBLED
R100k; 0603	R1			Yes
R470; 0603	R4			Yes
R0; 0603	R5			Yes
R2,2k; 0603	R6			Yes
R10k; 0603	R7			Yes
R470; 0603	R9			Yes
R56; 0603	R11			Yes
R10k; 3634; potentiometer	R12			Yes
DIP Switch	SW1	Würth Elektronik	418121270801	Yes
LED green; 0603	D1	Würth Elektronik	150080GS75000	Yes
MagI <sup>3</sup> C Power Module 2A	MP1	Würth Elektronik	171020601	Yes
X5R; 10 $\mu$ F; 50V; 1206	C3, C4			Yes
X7R; 4700pF; 25V; 0603	C10			Yes
X7R; 0.022 $\mu$ F; 100V; 0805	C17			Yes
Z-Diode; 3,3V; SOD123	Z1			Yes

## AN 178020601/WPMDH1200601JEV

**MagI<sup>3</sup>C** Power Module Product Family  
**VDRM - Variable Step Down Regulator Module**

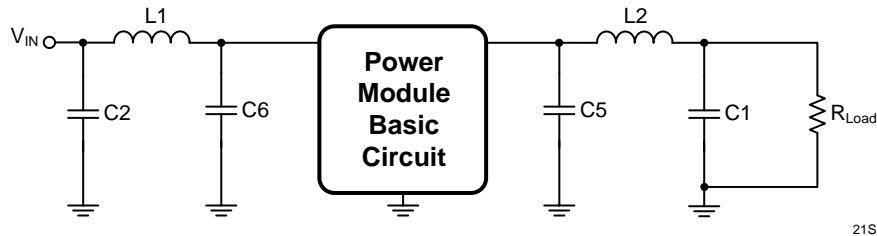
**D OPTIMIZED BOARD CIRCUIT**

21S

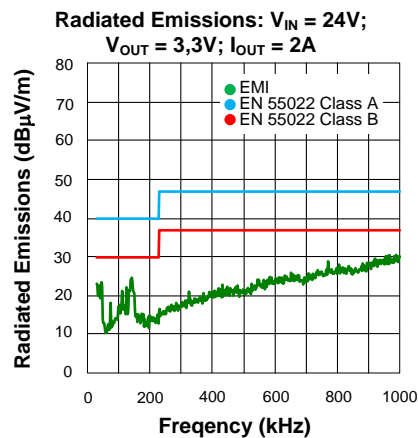

41D

**D1 Bill of Materials for the optimal EMI Board Schematic**

PART	POSITION	MANUFACTURER	ORDER CODE	ASSEMBLED
Ferrite; R880; 1812	L1, L2	Würth Elektronik	74279252	Yes
Tantal; 22μF; 50V; 2924	C1, C2			Yes
100μF; 6,3V; SMD 6.3x6.3mm	C5			No
100μF; 50V; SMD 6.3x6.3mm	C6			No

**E QUICK USER GUIDE<sup>(1)</sup>**

- At first turn on the power supply and preset the output voltage to 24V then turn off the power supply.
- On the Evaluation board, connect the  $V_{IN}$  terminal to the positive output of the power supply then connect GND terminal with the 0V output on the power supply.
- Visually check to ensure that the switch on the Evaluation Board is on OFF.
- Turn on the power supply and then operate the switch on the Evaluation Board to the ON position, now preset the output voltage on the evaluation board with the potentiometer to set the desired output voltage.
- Switch the power supply off and connect the  $V_{OUT}$  to the positive terminal and the GND to the 0V terminal of the load. Please note that the load is disabled and thus detect only the voltage
- Turn on the power supply and the module will startup. Then turn on the load and start at the minimum current and increase this in small steps until the maximum current of the evaluation board is achieved.
- The  $V_{IN}$ -Sense and  $V_{OUT}$ -Sense is for detecting the voltage on a volt meter.

**NOTE**

- (1) Please consider the ratings and specifications of the device in use.

AN 178020601/WPMDH1200601JEV

MagI<sup>3</sup>C Power Module Product Family  
 VDRM - Variable Step Down Regulator Module



F PCB LAYOUT OF THE EVALUATION BOARD

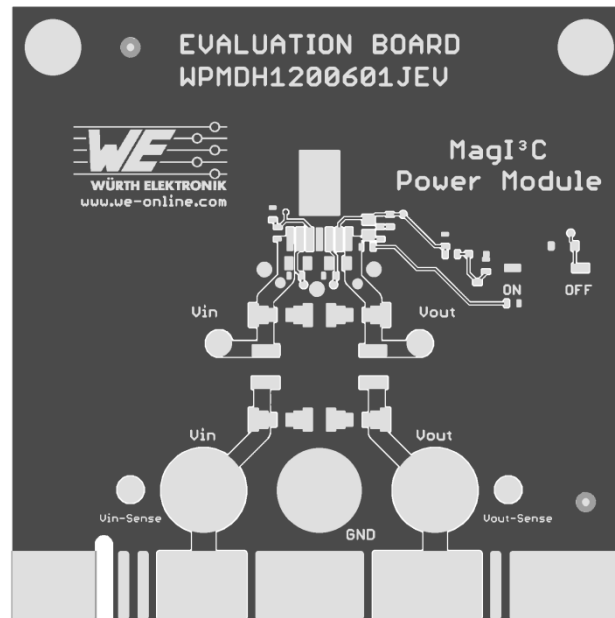

Top Layer

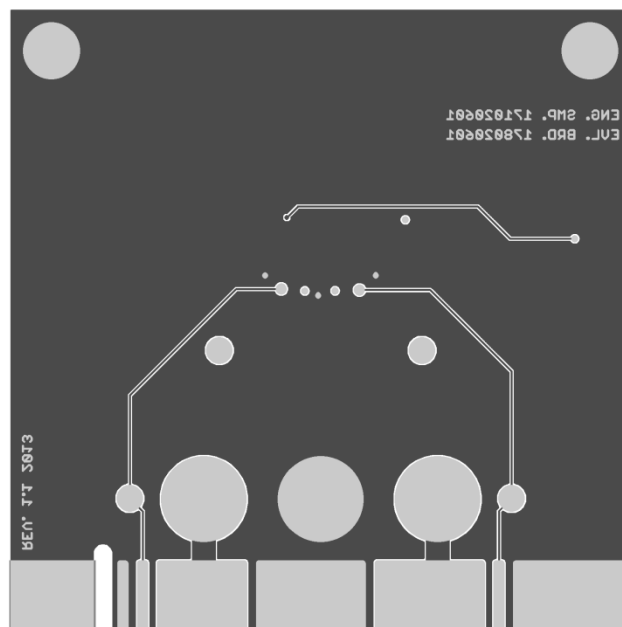

Bottom Layer



G TYPICAL PERFORMANCE CURVES

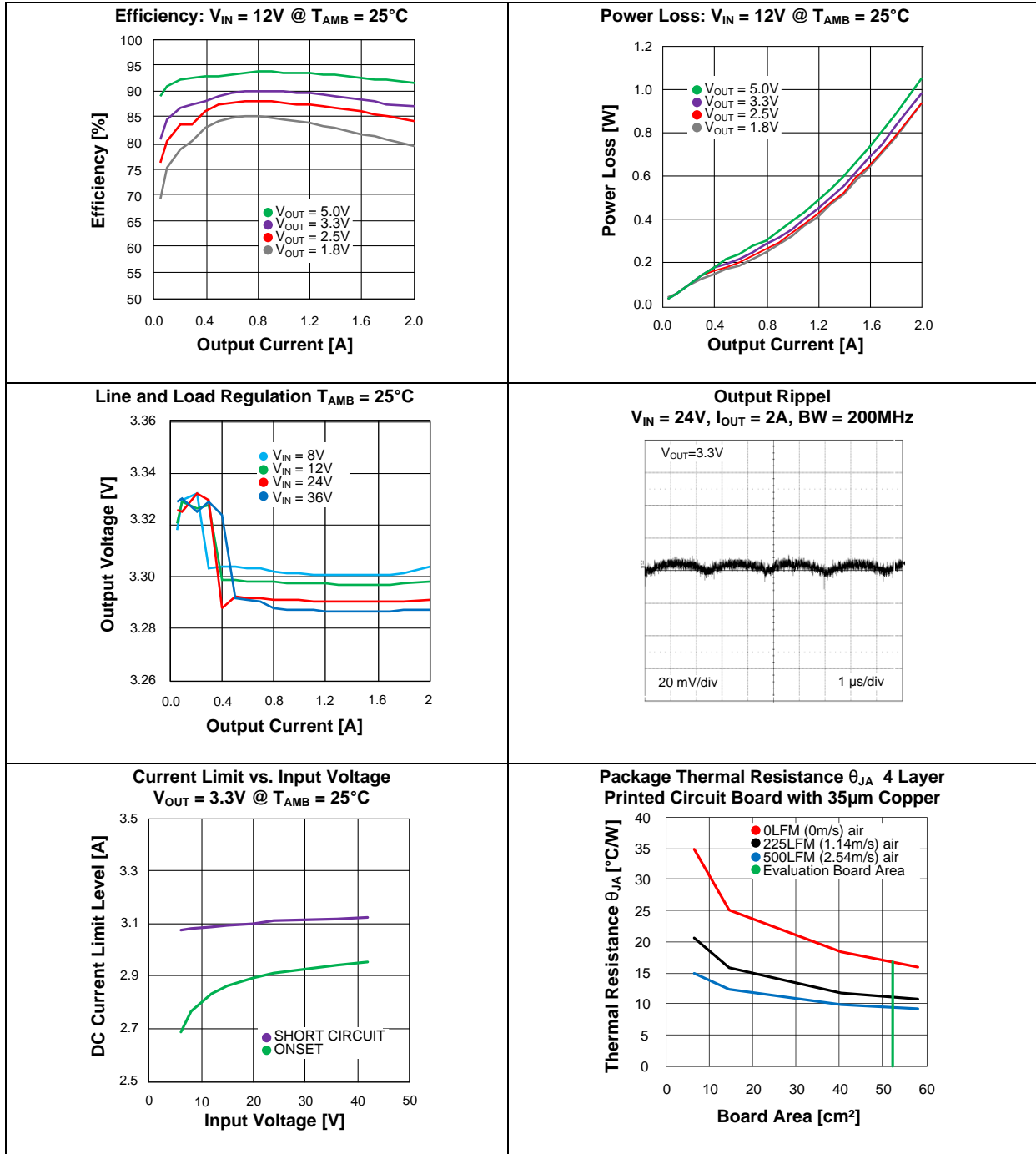

**AN 178020601**/WPMDH1200601JEV**MagI<sup>3</sup>C** Power Module Product Family  
**VDRM** - Variable Step Down Regulator Module**DOCUMENT HISTORY**

REVISION	DATE	DESCRIPTION	RESPONSIBLE
0.1	14.08.2013	Acceptance of a document	Michael Berger

AN 178020601/WPMDH1200601JEV

## MagI<sup>3</sup>C Power Module Product Family

### VDRM - Variable Step Down Regulator Module



#### CAUTIONS AND WARNINGS

The following conditions apply to all goods within the product series of MagI<sup>3</sup>C of Würth Elektronik eiSos GmbH & Co. KG:

##### General:

All recommendations according to the general technical specifications of the data-sheet have to be complied with.

The disposal and operation of the product within ambient conditions which probably alloy or harm the component surface has to be avoided.

If the product is potted in customer applications, the potting material might shrink during and after hardening. Accordingly to this the product is exposed to the pressure of the potting material with the effect that the body and termination is possibly damaged by this pressure and so the electrical as well as the mechanical characteristics are endanger to be affected. After the potting material is cured, the body and termination of the product have to be checked if any reduced electrical or mechanical functions or destructions have occurred.

The responsibility for the applicability of customer specific products and use in a particular customer design is always within the authority of the customer. All technical specifications for standard products do also apply for customer specific products.

Washing varnish agent that is used during the production to clean the application might damage or change the characteristics of the body, pins or termination. The washing varnish agent could have a negative effect on the long turn function of the product. Direct mechanical impact to the product shall be prevented as the material of the body, pins or termination could flake or in the worst case it could break. As these devices are sensitive to electrostatic discharge customer shall follow proper IC Handling Procedures.

Customer acknowledges and agrees that it is solely responsible for compliance with all legal, regulatory and safety-related requirements concerning its products, and any use of Würth Elektronik eiSos GmbH & Co. KG components in its applications, notwithstanding any applications-related information or support that may be provided by Würth Elektronik eiSos GmbH & Co. KG. Customer represents and agrees that it has all the necessary expertise to create and implement safeguards which anticipate dangerous consequences of failures, monitor failures and their consequences lessen the likelihood of failures that might cause harm and take appropriate remedial actions. Customer will fully indemnify Würth Elektronik eiSos and its representatives against any damages arising out of the use of any Würth Elektronik eiSos GmbH & Co. KG components in safety-critical applications.

##### Product specific:

Follow all instructions mentioned in the datasheet, especially:

- The solder profile has to be complied with according to the technical reflow/ or wave soldering specification, otherwise no warranty will be sustained.
- All products are supposed to be used before the end of the period of 12 months based on the product date-code, if not a 100% solderability can't be warranted.
- Violation of the technical product specifications such as exceeding the absolute maximum ratings will result in the loss of warranty.
- It is also recommended to return the body to the original moisture proof bag and reseal the moisture proof bag again.
- ESD prevention methods need to be followed for manual handling and processing by machinery.

AN 178020601/WPMDH1200601JEV

## MagI<sup>3</sup>C Power Module Product Family

### VDRM - Variable Step Down Regulator Module



#### IMPORTANT NOTES

The following conditions apply to all goods within the product range of Würth Elektronik eiSos GmbH & Co. KG:

##### 1. General Customer Responsibility

Some goods within the product range of Würth Elektronik eiSos GmbH & Co. KG contain statements regarding general suitability for certain application areas. These statements about suitability are based on our knowledge and experience of typical requirements concerning the areas, serve as general guidance and cannot be estimated as binding statements about the suitability for a customer application. The responsibility for the applicability and use in a particular customer design is always solely within the authority of the customer. Due to this fact it is up to the customer to evaluate, where appropriate to investigate and decide whether the device with the specific product characteristics described in the product specification is valid and suitable for the respective customer application or not. Accordingly, the customer is cautioned to verify that datasheet are current before placing orders.

##### 2. Customer Responsibility related to Specific, in particular Safety-Relevant Applications

It has to be clearly pointed out that the possibility of a malfunction of electronic components or failure before the end of the usual lifetime cannot be completely eliminated in the current state of the art, even if the products are operated within the range of the specifications. In certain customer applications requiring a very high level of safety and especially in customer applications in which the malfunction or failure of an electronic component could endanger human life or health it must be ensured by most advanced technological aid of suitable design of the customer application that no injury or damage is caused to third parties in the event of malfunction or failure of an electronic component.

##### 3. Best Care and Attention

Any product-specific notes, warnings and cautions must be strictly observed.

##### 4. Customer Support for Product Specifications

Some products within the product range may contain substances which are subject to restrictions in certain jurisdictions in order to serve specific technical requirements. Necessary information is available on request. In this case the field sales engineer or the internal sales person in charge should be contacted who will be happy to support in this matter.

##### 5. Product R&D

Due to constant product improvement product specifications may change from time to time. As a standard reporting procedure of the Product Change Notification (PCN) according to the JEDEC-Standard inform about minor and major changes. In case of further queries regarding the PCN, the field sales engineer or the internal sales person in charge should be contacted. The basic responsibility of the customer as per Section 1 and 2 remains unaffected.

##### 6. Product Life Cycle

Due to technical progress and economical evaluation we also reserve the right to discontinue production and delivery of products. As a standard reporting procedure of the Product Termination Notification (PTN) according to the JEDEC-Standard we will inform at an early stage about inevitable product discontinuance. According to this we cannot guarantee that all products within our product range will always be available. Therefore it needs to be verified with the field sales engineer or the internal sales person in charge about the current product availability expectancy before or when the product for application design-in disposal is considered. The approach named above does not apply in the case of individual agreements deviating from the foregoing for customer-specific products.

##### 7. Property Rights

All the rights for contractual products produced by Würth Elektronik eiSos GmbH & Co. KG on the basis of ideas, development contracts as well as models or templates that are subject to copyright, patent or commercial protection supplied to the customer will remain with Würth Elektronik eiSos GmbH & Co. KG. Würth Elektronik eiSos GmbH & Co. KG does not warrant or represent that any license, either expressed or implied, is granted under any patent right, copyright, mask work right, or other intellectual property right relating to any combination, application, or process in which Würth Elektronik eiSos GmbH & Co. KG components or services are used.

##### 8. General Terms and Conditions

Unless otherwise agreed in individual contracts, all orders are subject to the current version of the "General Terms and Conditions of Würth Elektronik eiSos Group", last version available at [www.we-online.com](http://www.we-online.com).