

Features

- 1-channel isolated barrier
- 24 V DC supply (bus powered)
- Dry contact or NAMUR inputs
- Application-specific outputs
- Usable as signal splitter (1 input and 2 outputs)
- 2 passive transistor outputs (resistive)
- Line fault transparency (LFT)
- Up to SIL 2 acc. to IEC 61508

Function

This isolated barrier is used for intrinsic safety applications.

The device transfers digital signals (NAMUR sensors or dry contacts) from a hazardous area to a safe area.

The input controls two passive transistor outputs with a resistive output characteristic.

The outputs have three defined states: 1-Signal = 6.5 V voltage drop, 0-Signal = 33 kΩ and 6.5 V voltage drop and fault > 100 kΩ.

This output characteristic offers line fault transparency on the signal lines.

Switches allow to reverse the output mode of operation and to disable the line fault detection of the field circuit.

This device mounts on a HiC Termination Board.

Application

This device is compatible to the control:

- Yokogawa ProSafe DI card SDV144

Compatibility check to other ESD/DCS systems on request.

Assembly

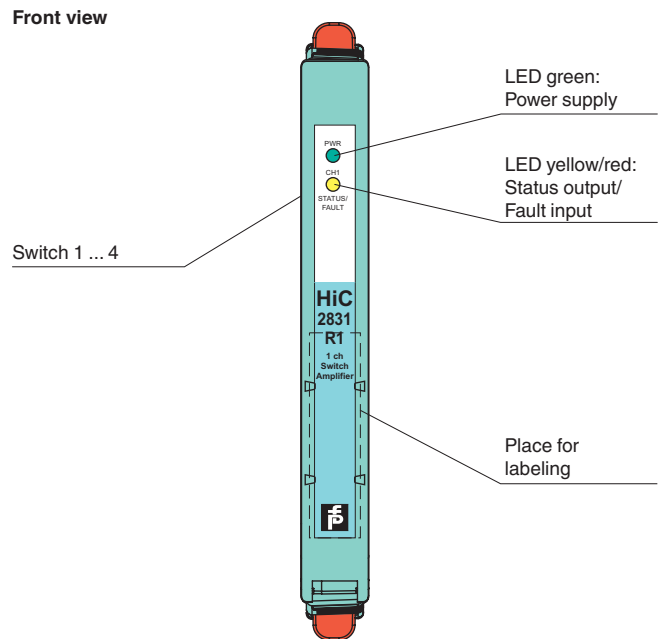

SIL 2

Connection

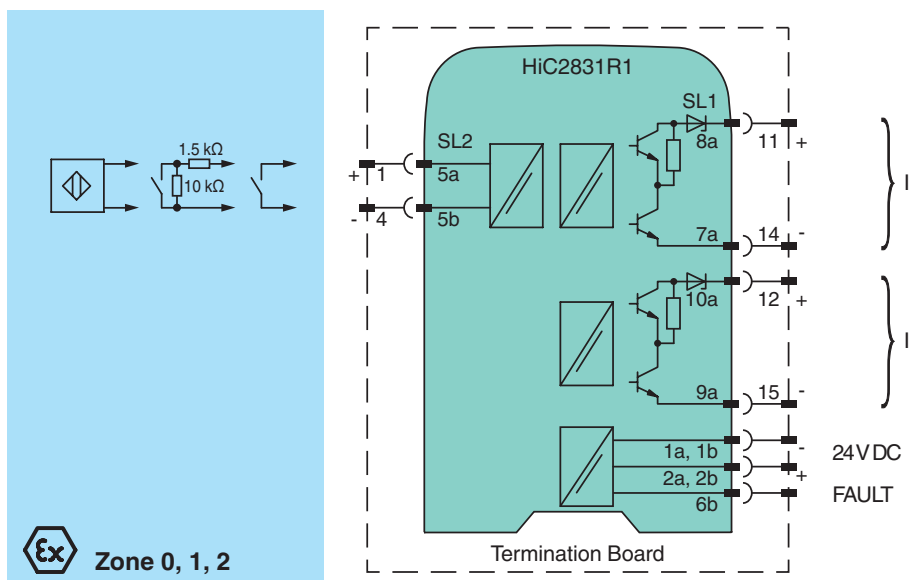

Release date 2016-09-12 11:40 Date of issue 2016-09-12 251579_eng.xml



Refer to "General Notes Relating to Pepperl+Fuchs Product Information".

Pepperl+Fuchs Group
www.pepperl-fuchs.com

USA: +1 330 486 0002
pa-info@us.pepperl-fuchs.com

Germany: +49 621 776 2222
pa-info@de.pepperl-fuchs.com

Singapore: +65 6779 9091
pa-info@sg.pepperl-fuchs.com

General specifications		
Signal type		Digital Input
Supply		
Connection		SL1: 1a(-), 1b(-); 2a(+), 2b(+)
Rated voltage	U_n	19 ... 30 V DC via Termination Board
Ripple		≤ 10 %
Rated current	I_n	≤ 25 mA
Power dissipation		≤ 500 mW
Power consumption		≤ 600 mW
Input		
Connection		SL2: 5a(+), 5b(-)
Rated values		acc. to EN 60947-5-6 (NAMUR), see system description for electrical data
Open circuit voltage/short-circuit current		approx. 10 V DC / approx. 8 mA
Switching point/switching hysteresis		1.2 ... 2.1 mA / approx. 0.2 mA
Line fault detection		breakage $I \leq 0.1$ mA , short-circuit $I \geq 6.5$ mA
Pulse/Pause ratio		≥ 100 μs / ≥ 100 μs
Output		
Connection		SL1: 8a(+), 7a(-); 10a(+), 9a(-)
Rated voltage	U_n	19 ... 30 V DC with external resistance > 2 kΩ, e. g. 16-channel ProSafe DI card SDV144 from Yokogawa
Response time		≤ 200 μs
Output I, II		signal or error message, passive transistor output (resistive) 0-signal: 33 kΩ ± 5 % + voltage drop 6.5 V ± 0.5 V 1-signal: voltage drop 6.5 V ± 0.5 V fault: > 100 kΩ
Error message output		
Connection		SL1: 6b
Output type		open collector transistor (internal fault bus)
Transfer characteristics		
Switching frequency		≤ 5 kHz
Electrical isolation		
Output/power supply		basic insulation according to IEC/EN 61010-1, rated insulation voltage 60 V _{eff}
Output/Output		basic insulation according to IEC/EN 61010-1, rated insulation voltage 60 V _{eff}
Directive conformity		
Electromagnetic compatibility		
Directive 2014/30/EU		EN 61326-1:2013 (industrial locations)
Conformity		
Electromagnetic compatibility		NE 21:2012 , EN 61326-3-2:2008
Degree of protection		IEC 60529:2001
Protection against electrical shock		IEC 61010-1
Ambient conditions		
Ambient temperature		-20 ... 60 °C (-4 ... 140 °F)
Mechanical specifications		
Degree of protection		IP20
Mass		approx. 100 g
Dimensions		12.5 x 128 x 106 mm (0.5 x 5.1 x 4.2 inch)
Mounting		on Termination Board
Coding		pin 1 and 2 trimmed For further information see system description.
Data for application in connection with hazardous areas		
EC-Type Examination Certificate		BVS 11 ATEX E 026
Group, category, type of protection		 II (1) G [Ex ia] IIC, II (1) D [Ex ia] IIIC  I (M1) [Ex ia] I
Input		Ex ia
Voltage	U_o	10.5 V
Current	I_o	17.1 mA
Power	P_o	45 mW (linear characteristic)
Supply		
Maximum safe voltage	U_m	253 V AC (Attention! U_m is no rated voltage.)
Output		
Maximum safe voltage	U_m	253 V AC (Attention! U_m is no rated voltage.)
Statement of conformity		KIWA 15 ATEX 0037 X
Group, category, type of protection, temperature class		 II 3G Ex nA IIC T4 Gc
Electrical isolation		
Input/Output		safe electrical isolation acc. to IEC/EN 60079-11, voltage peak value 375 V

Release date 2016-09-12 11:40 Date of issue 2016-09-12 251579_eng.xml

Refer to "General Notes Relating to Pepperl+Fuchs Product Information".

Pepperl+Fuchs Group
www.pepperl-fuchs.com

USA: +1 330 486 0002
pa-info@us.pepperl-fuchs.com

Germany: +49 621 776 2222
pa-info@de.pepperl-fuchs.com

Singapore: +65 6779 9091
pa-info@sg.pepperl-fuchs.com

Input/power supply	safe electrical isolation acc. to IEC/EN 60079-11, voltage peak value 375 V
Directive conformity	
Directive 2014/34/EU	EN 60079-0:2012+A11:2013 , EN 60079-11:2012 , EN 60079-15:2010 , EN 50303:2000
International approvals	
UL approval	
Control drawing	116-0331
IECEX approval	IECEX BVS 11.0040
Approved for	[Ex ia Ga] IIC, [Ex ia] IIIC , [Ex ia] I
General information	
Supplementary information	EC-Type Examination Certificate, Statement of Conformity, Declaration of Conformity, Attestation of Conformity and instructions have to be observed where applicable. For information see www.pepperl-fuchs.com.

Configuration

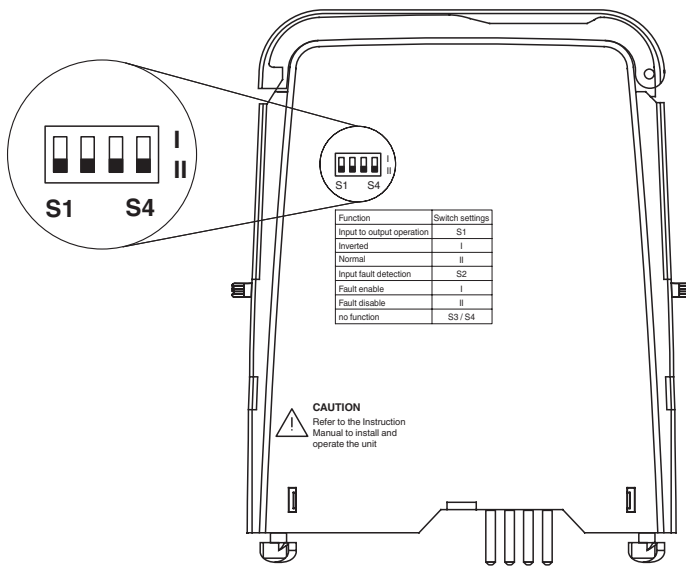

Switch settings

S	Function		Position
1	Mode of operation	Inverted	I
		Normal	II
2	Input line fault detection	ON	I
		OFF	II
3	no function		
4	no function		

Configure the device in the following way:

- Push the red Quick Lok Bars on each side of the device in the upper position.
- Remove the device from Termination Board.
- Set the DIP switches according to the figure.



The pins for this device are trimmed to polarize it according to its safety parameter. Do not change! For further information see system description.

Trip points

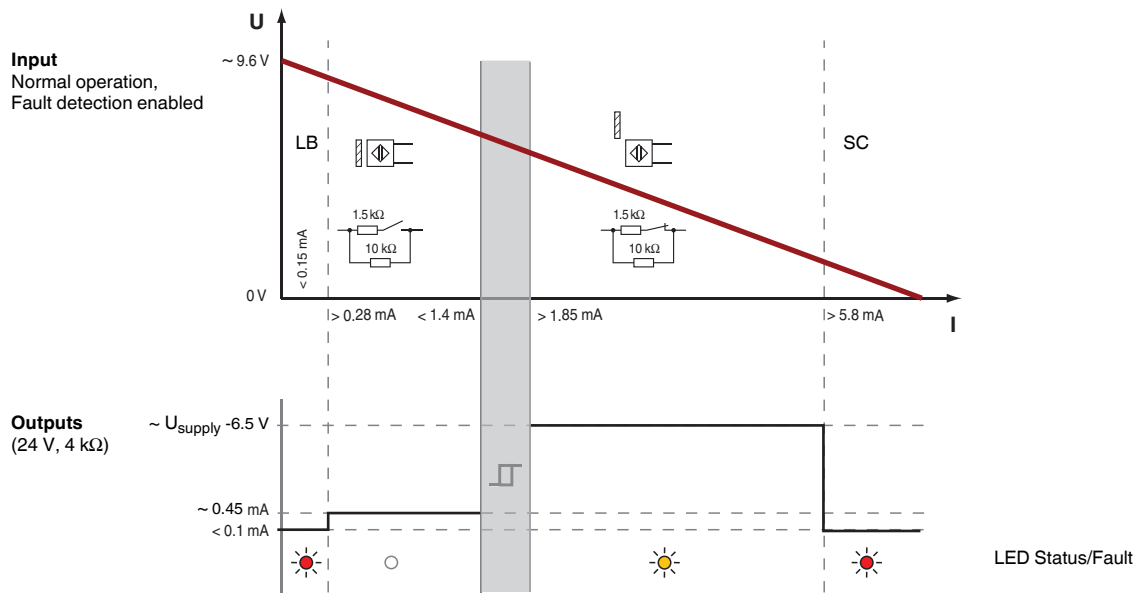

Release date 2016-09-12 11:40 Date of issue 2016-09-12 251579_eng.xml

Refer to "General Notes Relating to Pepperl+Fuchs Product Information".

Pepperl+Fuchs Group
www.pepperl-fuchs.com

USA: +1 330 486 0002
pa-info@us.pepperl-fuchs.com

Germany: +49 621 776 2222
pa-info@de.pepperl-fuchs.com

Singapore: +65 6779 9091
pa-info@sg.pepperl-fuchs.com