

Locking Assemblies BAR

Material: Steel.

- For fixing a hub (e.g. drive wheel, rotor or similar) on a shaft.
- For medium torques.
- Very good distribution of pressure.
- Very good self-centering.
- Self-releasing at dismounting.
- Also suitable for large hub and shaft tolerances.
- Slight axial offset possible during assembly.

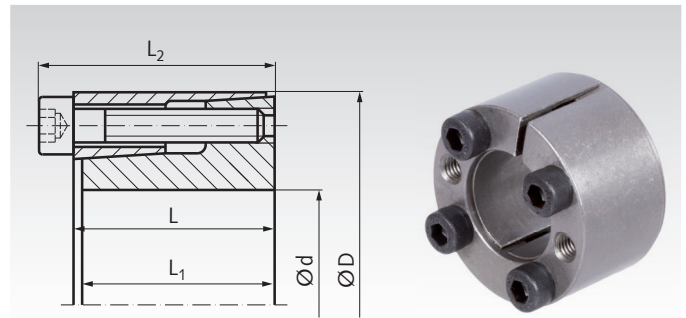

Ordering Details: e.g.: Product No. 615 405 00, Locking Assembly BAR 5 mm

Product No.	d mm	D mm	L mm	L ₁ mm	L ₂ mm	at T _A transmittable		Surface Pressure		Tensioning Screw 12.9			Weight kg
						T Nm	F _{ax} kN	at Shaft P _w N/mm ²	at Hub P _N N/mm ²	Size DIN 912	T _A Nm	Number	
615 405 00	5	16	11	10,5	13,5	6	2	150	55	M2,5 x 10	1,2	3	0,012
615 406 00	6	16	11	10,5	13,5	9	3	188	69	M2,5 x 10	1,2	3	0,012
615 406 35	6,35	16	11	10,5	13,5	10	3	180	72	M2,5 x 10	1,2	3	0,012
615 407 00	7	17	11	10,5	13,5	11	3	155	64	M2,5 x 10	1,2	3	0,013
615 408 00	8	18	11	10,5	13,5	12	3	141	62	M2,5 x 10	1,2	3	0,015
615 409 00	9	20	13	12,5	15,5	17	4	132	60	M2,5 x 12	1,2	4	0,020
615 409 53	9,53	20	13	12,5	15,5	18	4	124	59	M2,5 x 12	1,2	4	0,020
615 410 00	10	20	13	12,5	15,5	19	4	120	60	M2,5 x 12	1,2	4	0,019
615 411 00	11	22	13	12,5	15,5	21	4	108	54	M2,5 x 12	1,2	4	0,024
615 412 00	12	22	13	12,5	15,5	24	4	102	55	M2,5 x 12	1,2	4	0,022
615 412 70	12,7	23	13	12,5	15,5	24	4	102	55	M2,5 x 12	1,2	4	0,020
615 414 00	14	26	17	16,5	20	40	6	94	50	M3 x 16	2,1	4	0,039
615 415 00	15	28	17	16,5	20	44	6	93	50	M3 x 16	2,1	4	0,044
615 416 00	16	32	17	16,5	21	86	10	158	79	M4 x 16	4,9	4	0,067
615 417 00	17	35	21	20,5	25	88	10	116	56	M4 x 20	4,9	4	0,090
615 418 00	18	35	21	20,5	25	94	11	110	57	M4 x 20	4,9	4	0,087
615 419 00	19	35	21	20,5	25	99	11	104	56	M4 x 20	4,9	4	0,083
615 420 00	20	38	21	20,5	26	179	17	169	89	M5 x 20	10	4	0,10
615 422 00	22	40	21	20,5	26	187	18	146	80	M5 x 20	10	4	0,11
615 424 00	24	47	26	25	32	290	24	155	79	M6 x 25	17	4	0,20
615 425 00	25	47	26	25	32	300	24	147	78	M6 x 25	17	4	0,19
615 425 40	25,4	47	26	25	32	310	24	145	79	M6 x 25	17	4	0,18
615 428 00	28	50	26	25	32	480	34	186	105	M6 x 25	17	6	0,22
615 430 00	30	55	26	25	32	510	34	174	95	M6 x 25	17	6	0,27
615 432 00	32	55	26	25	32	600	38	181	105	M6 x 25	17	6	0,25
615 435 00	35	60	31	30	37	820	47	172	100	M6 x 30	17	8	0,36
615 438 00	38	65	31	30	37	880	47	157	92	M6 x 30	17	8	0,43
615 440 00	40	65	31	30	37	1000	50	171	99	M6 x 30	17	8	0,40
615 442 00	42	75	36	35	44	1410	67	177	99	M8 x 35	41	6	0,67
615 445 00	45	75	36	35	44	1510	67	165	99	M8 x 35	41	6	0,63
615 448 00	48	80	36	35	44	2150	86	206	123	M8 x 35	41	8	0,74
615 450 00	50	80	36	35	44	2150	89	190	118	M8 x 35	41	8	0,70
615 455 00	55	85	42	40	50	2772	110	270	174	M8 x 40	41	8	0,77
615 460 00	60	90	42	40	50	3060	120	248	166	M8 x 40	41	8	0,82
615 465 00	65	95	42	40	50	3645	120	253	174	M8 x 40	41	9	0,88
615 470 00	70	110	48	45	58	5724	180	283	182	M10 x 45	80	8	1,59
615 475 00	75	115	48	45	58	6210	180	268	129	M10 x 45	80	8	1,67
615 480 00	80	120	54	50	64	6660	190	260	130	M10 x 50	80	8	1,76
615 485 00	85	125	54	50	64	7560	190	273	123	M10 x 50	80	9	1,85
615 490 00	90	130	58	55	68	8100	200	233	121	M10 x 55	80	9	1,94
615 495 00	95	135	58	55	68	9900	230	271	140	M10 x 55	80	10	2,02
615 500 00	100	145	58	55	70	11790	260	265	186	M12 x 55	145	8	2,90

T = transmittable torque at F_{ax} = 0.
 F_{ax} = transmittable axial force at T = 0.
 P_w = surface pressure onto the shaft.
 P_N = surface pressure onto the hub.
 T_A = fastening torque of the screws.

Fit, Surface

Shaft and hub up to tolerance h8/H8.
 Surface finish for shaft and hub R_z < 12.5 µm.

Mounting

The locking assembly has to sit inside the bore by at least the measure „L“. Slightly oil the locking assembly before mounting, do not use molybdenum disulphide or fat. Tighten the screws evenly and crosswise in several steps.

Demounting

Remove all tensioning screws and screw them into the (usually unused) forcing thread of the front ring, until the ring is released.