

GN 709.2 | Locking elements with threaded blind hole

Steel



- 1
- 2
- 3
- 4
- 5
- 6
- 7
- 8
- 9
- 10
- 11
- 12
- 13
- 14
- 15
- 16
- 17
- 18

MATERIAL

Hardened phosphated steel.

ELASTIC ELEMENT

Polyurethane (PUR).

STANDARD EXECUTIONS

Hardened steel ball:

- **GN 709.2-B**: ball with smooth and flat face, not reversible.
- **GN 709.2-BR**: ball with smooth and flat face, not reversible, with automatic return.
- **GN 709.2-R**: ball with knurled and flat face, not reversible.
- **GN 709.2-RR**: ball with knurled and flat face, not reversible, with automatic return.

FEATURES AND APPLICATIONS

GN 709.2 clamping elements are used as mobile supports or for clamping workpieces.

Maximum inclination of the ball plane = 9°.

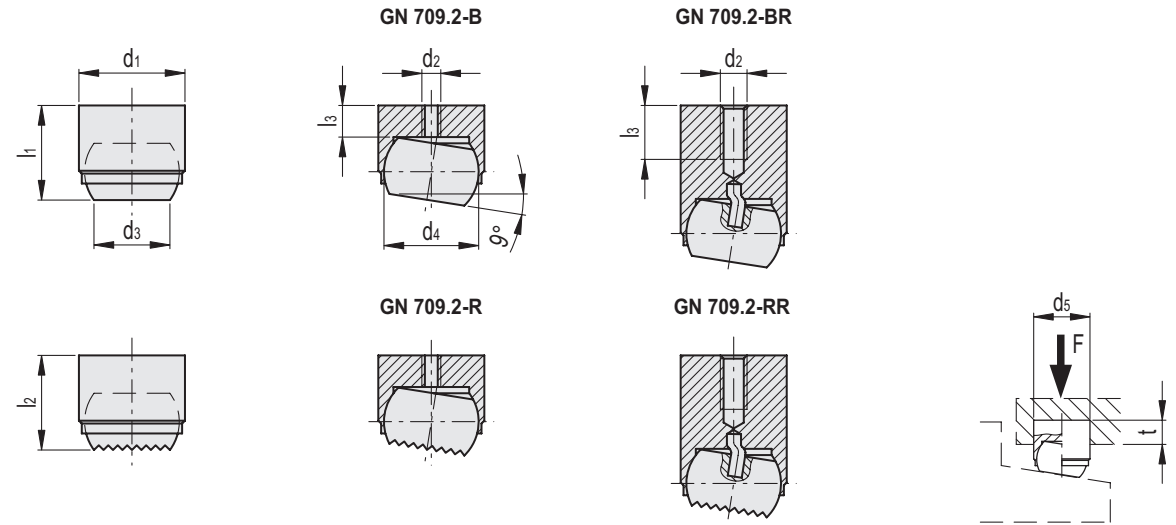

GN 709.2-B

Code	Description	d1 n6	d2	d3	d4	l1 ±0.02	l3	d5 H7	t min.	Max. static load F [kN]	⚖
GN.76101	GN 709.2-12-B	12	M3	7.2	10	11	3.2	12	6	10	8
GN.76111	GN 709.2-18-B	18	M4	10.5	16	17	4	18	8	25	30
GN.76121	GN 709.2-28-B	28	M5	20	25	25	5.5	28	13	90	80

GN 709.2-BR

GN.76102	GN 709.2-12-BR	12	M3	7.2	10	17	3.2	12	12	10	8
GN.76112	GN 709.2-18-BR	18	M4	10.5	16	23	4	18	14	25	39
GN.76122	GN 709.2-28-BR	28	M5	20	25	34	6	28	22	90	140

GN 709.2-R

Code	Description	d1 n6	d2	d3	d4	l2 ±0.1	l3	d5 H7	t min.	Max. static load F [kN]	⚖
GN.76106	GN 709.2-12-R	12	M3	7.2	10	11	3.2	12	6	10	10
GN.76116	GN 709.2-18-R	18	M4	10.5	16	17	4	18	8	25	30
GN.76126	GN 709.2-28-R	28	M5	20	25	25	5.5	28	13	90	80

GN 709.2-RR

GN.76107	GN 709.2-12-RR	12	M3	7.2	10	17	3.2	12	12	10	32
GN.76117	GN 709.2-18-RR	18	M4	10.5	16	23	4	18	14	25	40
GN.76127	GN 709.2-28-RR	28	M5	20	25	34	6	28	22	90	150

Standard machine parts