

DO NOT SCALE DRAWING

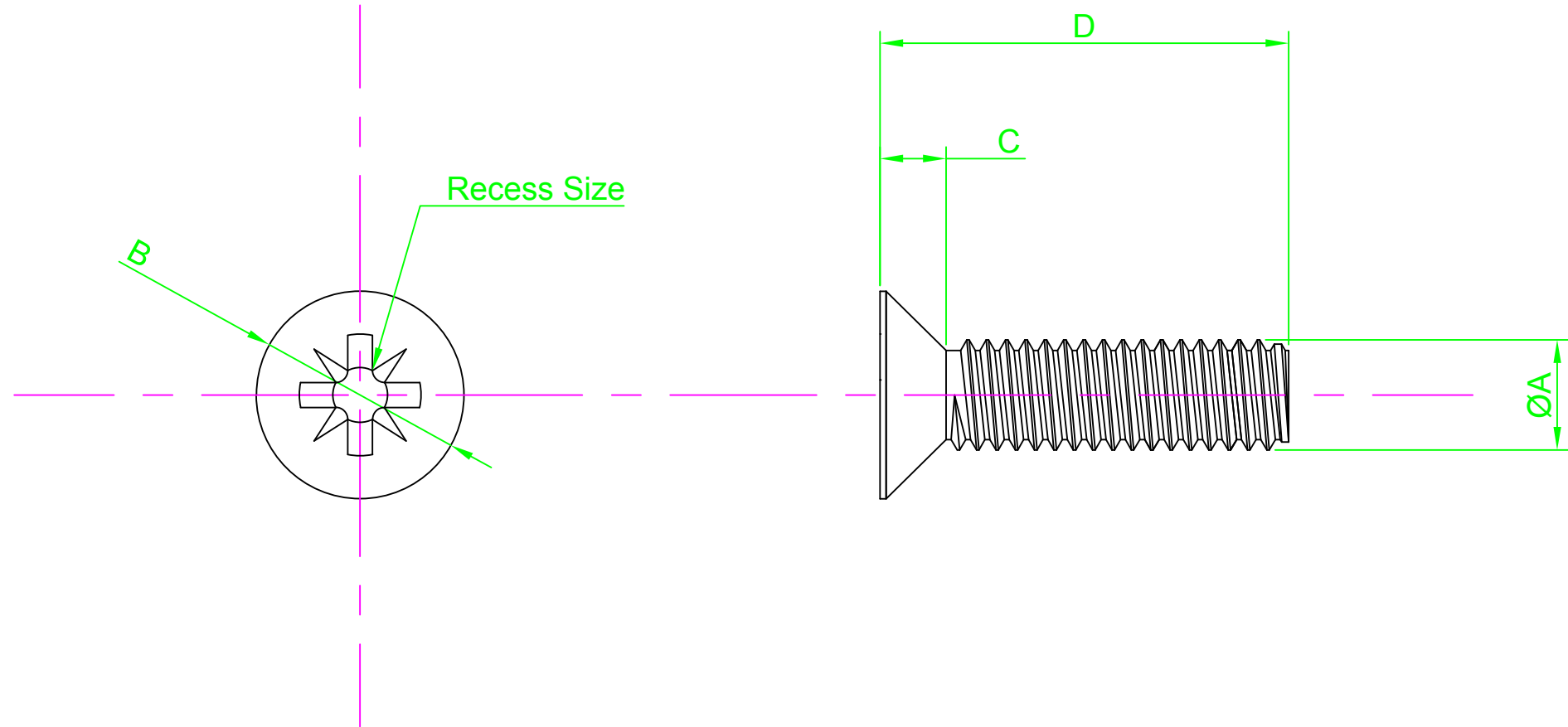

REVISION

A INITIAL DRAWING 23.9.15

Part Number	ØA	B Nom	C Max	D Length	Recess Size
M3 6 KRA2MC S100	M3-0.5	5.6	1.65	6	Pozi #1
M3 12 KRA2MC S100				12	
M3 20 KRA2MC S100				20	
M4 12 KRA2MC S100	M4-0.7	7.5	2.2	12	Pozi #2
M4 16 KRA2MC S100				16	
M4 20 KRA2MC S100				20	
M5 12 KRA2MC S100	M5-0.8	9.2	2.5	12	Pozi #2
M5 16 KRA2MC S100				16	
M5 20 KRA2MC S100				20	

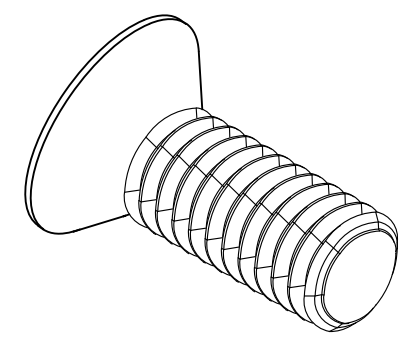

NOTES:



DESIGN RIGHT. TR FASTENINGS LTD, 2003
 UNDER NO CIRCUMSTANCES MUST THIS
 DRAWING BE COPIED OR DISCLOSED
 WITHOUT FIRST OBTAINING WRITTEN
 AUTHORITY.

UNLESS OTHERWISE SPECIFIED:
 DIMENSIONS ARE IN MM (MILLIMETERS).
 SURFACE FINISH:
 TOLERANCES: DIN 965

	NAME	DATE
DRAWN	Darryl Wilson	23.09.15
CHK'D		
APPVD		

MATERIAL:
 Stainless Steel A2

HEAT TREATMENT:
 N/A

FINISH:
 Self Finish

TITLE:
 Pozi Csk Head Machine Screw DIN 965

DRAWING NUMBER:
 TR32KRA2MC-S100

A4