



SEK 19 male standard connector solder angled



General information

Design	IEC 60603-13		
No. of contacts	6,10,14,16,20,24,26,30,34,40,50,60,64		
Contact spacing	2,54 mm x 2,54 mm		
Test voltage Ur.m.s	1 kV		
Working voltage	500 V for pollution degree 1		
Contact resistance	max. 20mOhm		
Insulation resistance	min. 10 ⁹ Ohm		
Working current acc. to IEC 60512-2	See derating diagram		
Temperature range	-55°C ... +125°C		
Termination technology	solder		
Clearance & creepage distance	min. 0,5 mm clearance min. 0,56 creepage		
Insertion and withdrawal forces	6-pole max. 12N for PL1-2 / 18N for PL3	; 30-pole max. 60N for PL1-2 / 90N for PL3	
	10-pole max. 20N for PL1-2 / 30N for PL3	; 34-poles max. 68N for PL1-2 / 102N for PL3	
	14-pole max. 28N for PL1-2 / 42 for PL3	; 40-poles max. 80N for PL1-2 / 120N for PL3	
	16-pole max. 32N for PL1-2 / 48N for PL3	; 50-poles max. 100N for PL1-2 / 150N for PL3	
	20-pole max. 40N for PL1-2 / 60N for PL3	; 60-poles max. 120N for PL1-2 / 180N for PL3	
	24-pole max. 48N for PL1-2 / 72N for PL3	; 64-poles max. 128N for PL1-2 / 192N for PL3	
Mating cycles	S4 surface treatment	Au over PdNi (min. 0,76 µm)	
	PL 1 acc. to IEC 60603-13	500 mating cycles	10 days gas test
	PL 2 acc. to IEC 60603-13	250 mating cycles	4 days gas test
	PL 3 acc. to IEC 60603-13	50 mating cycles	No gas test
UL file	No		
RoHS - compliant	Yes		
Leadfree	Yes		
Hot plugging	No		

Insulator material

Material	PCT (thermoplastics, glass fiber reinforcement 30%)		
Color	Black (RAL 7001) or beige		
UL classification	UL94-V0		
Material group acc. IEC 60664-1	II (400 < CTI < 600)		
NF F 16-101 classification	No		

Contact material

Contact material	Copper alloy		
Plating termination zone	Sn over Ni		
Plating contact sliding side	Au or Au over PdNi (according to performance level)		

Derating diagram acc. to IEC 60512-2 (Current carrying capacity)

The current carrying capacity is limited by maximum temperature of materials for inserts and contacts including terminals. The current capacity-curve is valid for continuous, not interrupted current-loaded contacts of connectors when simultaneous power on all contacts is given without exceeding the maximum temperature. Control and test procedures according to DIN IEC 60512.

- 1) Temperature rise
- 2) Derating
- 3) Derating curve at I max x 0.8(IEC 60512-2)

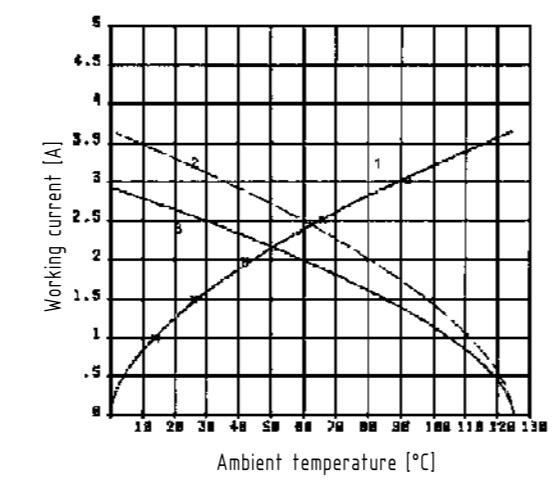

Soldering instructions

THR (Through Hole Reflow) connectors are designed to be used in a reflow oven. THR connectors can also be used together with SMD (Surface Mount Device) components in a reflow oven. In this process, called as well "Pin in hole intrusive reflow", the connectors are inserted into plated through holes in a comparable way to conventional component mounting. All other components can be assembled on the PCB surface.

The length of the connector contacts should be such that they protrude by no more than 1,5 millimeters after insertion to the PCB. Each contact collects solder on its tip as it penetrates the solder paste in the hole. So if the contact is too long, this solder would no longer be able to reflow back into the plated through hole by capillary action during the soldering process, therefore the quality of the soldered connection would suffer as a result.

Quantity of solder paste

Before the components are assembled, solder paste must be applied to all solder pads (for connecting surface-mount components) and the plated through holes. To ensure that the plated through holes are completely filled, significantly more solder paste must be applied than traditional solder pads on the PCB. The following rule of thumb has proved valuable in practice:

$$V_{paste} = 2(VH - VP)$$

in which:
 V_{paste} = Required volume of solder paste
 VH = Volume of plated through hole
 VP = Volume of the connector termination in the hole

comment: the multiplier "2" compensates for solder paste shrinkage during soldering. For this purpose, it was assumed that 50% of the paste consists of the actual solder, the other 50% being soldering aids.

Cross section of solder terminations

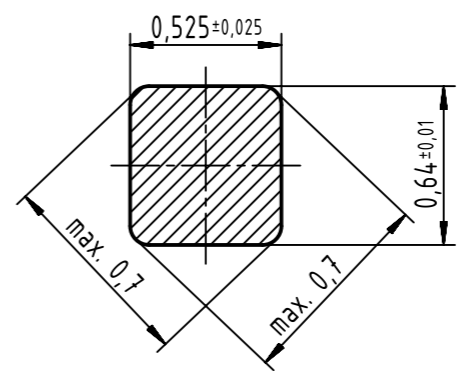

Packaging material (only for plastic tray)

Material	Polystyrol
Color	Yellow
Standardization	acc. to DIN EN / IEC 61340-5-1 and ANSI / ESD S541-2003

- Safe protection for electronic components against electrostatic charges

	All rights reserved	Created by	Inspected by	Standardisation	Date	State	
	Department EC PD - DE	STORCK	LEHNERT	HOFFMANN	2018-06-19	Final Release	
HARTING Electronics GmbH		Title				Doc-Key / ECM-Nr.	
D-32339 Espelkamp		SEK 19 male standard connector solder angled				100555123/UGD/001/H 500000132470	
		Type	Number		Rev.	Page	
		DS	09191130201		H	1/2	



SEK 19 male standard connector solder angled



Tape layout & packaging

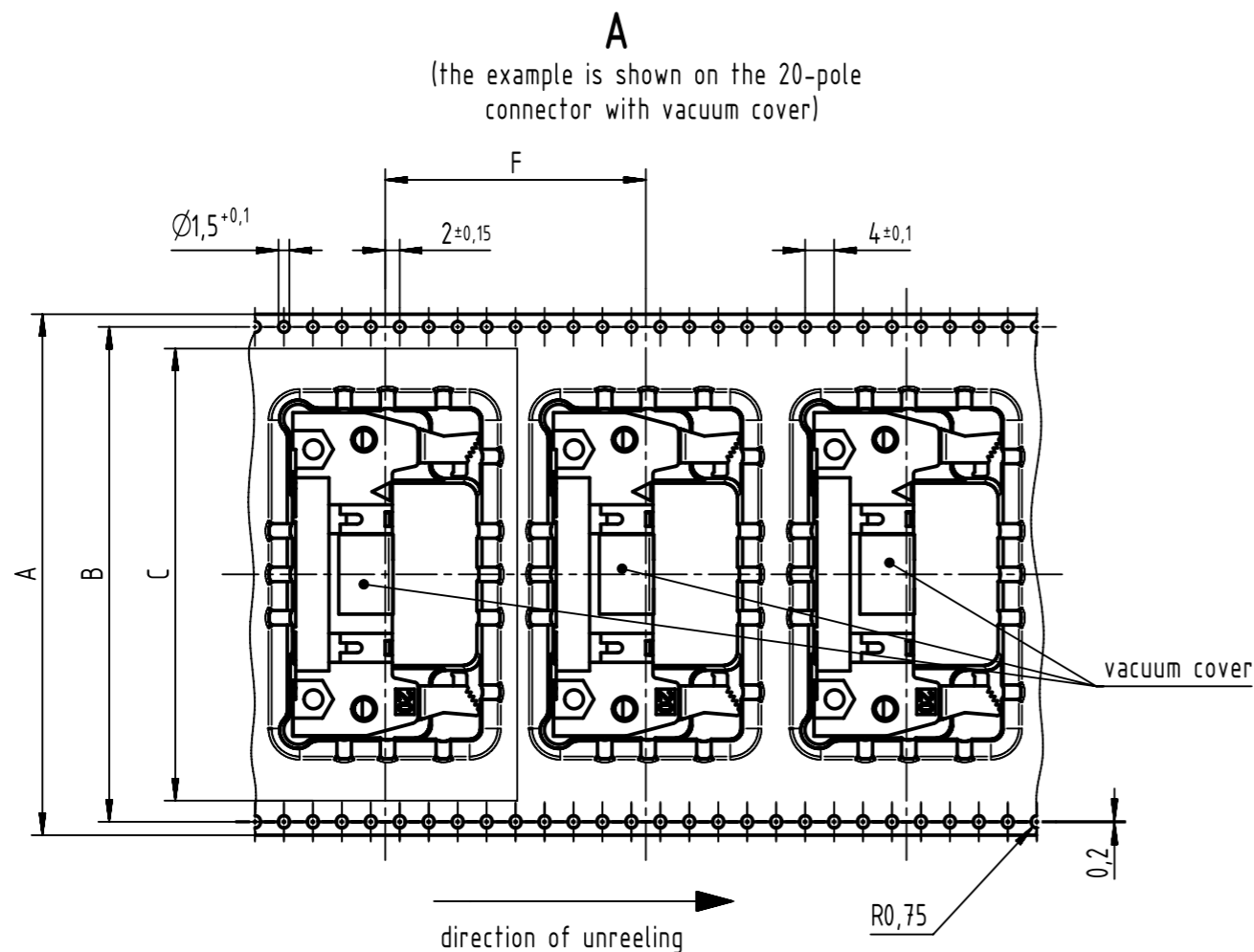

colour	vacuum cover	part number	remark
beige	X	09 19 5XX X903 740	
black	X	09 19 5XX X903 741	
beige	-	09 19 5XX X903 710	available on request
black	-	09 19 5XX X903 711	available on request

20	72	68,4	65,5	73	78	36	12,6	6	210	8
16										
14										
10	56	52,4	49,5	57	62	36	12,9	6	210	8
6										
contacts	A	B	C	D	E	F	G	-trailer- number of empty cavities	number of connector per reel	-leader- number of empty cavities

Reel dimension

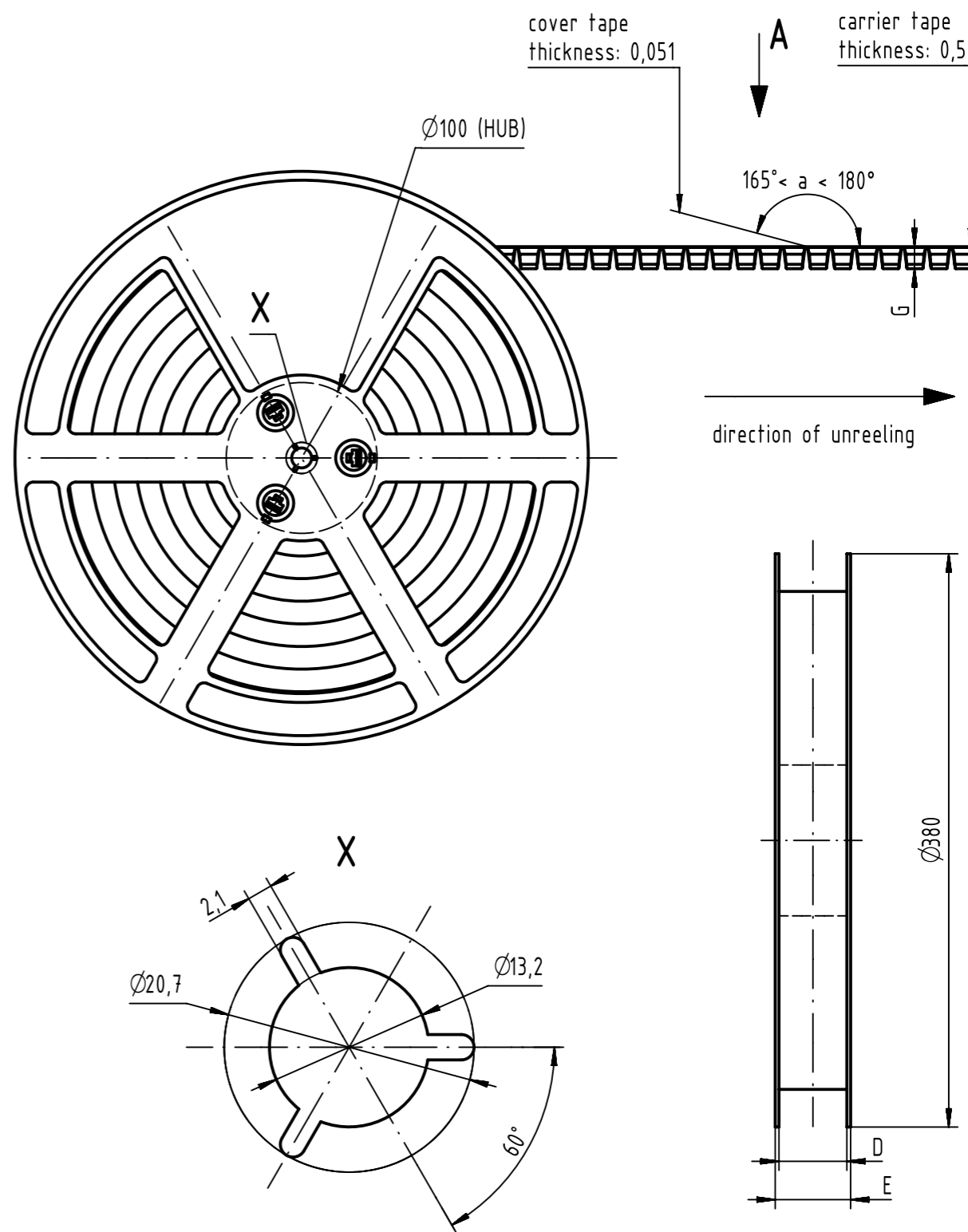

All Dimensions in mm
Original Size DIN A3

Scale
1:1

Free size tol.

Ref.

Sub.



All rights reserved
Department EC PD - DE

Created by
STORCK

Inspected by
LEHNERT

Standardisation
HOFFMANN

Date
2018-06-19

State
Final Release

Title
SEK 19 male standard connector solder angled

Doc-Key / ECM-Nr.
100555123/UGD/001/H
500000132470

Type
DS

Number
09191130201

Rev.
H

Page
2/2

HARTING Electronics GmbH
D-32339 Espelkamp