



### Main

|                              |                                       |
|------------------------------|---------------------------------------|
| Range of product             | Modicon TM3                           |
| Product compatibility        | Logic controller<br>Motion controller |
| Product or component type    | I/O distributed module                |
| Product specific application | Bus coupler module                    |

### Complementary

|                             |   |
|-----------------------------|---|
| Communication port protocol | Ethernet IP/Modbus TCP  |
| Connector type              | RJ45 2 Ethernet daisy chain isolated<br>USB device port Mini-B  |
| Exchange mode               | Half duplex, full duplex, autonegotiation   |
| Transmission rate           | 10/100 Mbit/s   |
| Topology                    | Daisy chain   |
| Port Ethernet               | 10/100BASE-T  |
| Communication network type  | Ethernet IP<br>Modbus TCP<br>IPv4 (internet protocol)   |
| Communication service       | Ethernet/IP adapter<br>Modbus TCP/IP server<br>RSTP (Ring topology support)<br>SNMP<br>Web server<br>DHCP client<br>BOOTP<br>Address conflict detection<br>FTP server |
| Web services                | Web server, Ethernet<br>Web server, USB   |
| Current consumption         | 0.8 A at 24 V DC internal supply maximum 7 expansion modules  |
| Local signalling            | 1 LED green/red for PWR (System Status)<br>1 LED green/red for MS (Module Status)<br>1 LED green/red for NS (Network Status)<br>1 LED green/red for I/O status        |
| Fixing mode                 | By clipping locks (rail)<br>By screws (mounting plate)  |
| Width                       | 27 mm   |
| Height                      | 96.5 mm   |
| Depth                       | 70 mm   |
| Net weight                  | 0.10 kg   |

The information provided in this documentation contains general descriptions and/or technical characteristics of the performance of the products contained herein. This documentation is not intended as a substitute for and is not to be used for determining suitability or reliability of these products for specific user applications. It is the duty of any such user or integrator to perform the appropriate and complete risk analysis, evaluation and testing of the products with respect to the relevant specific application or use thereof. Neither Schneider Electric Industries SAS nor any of its affiliates or subsidiaries shall be responsible or liable for misuse of the information contained herein.

## Environment

|                                       |  |
|---------------------------------------|--|
| Ambient air temperature for storage   | -25...70 °C                            |
| Pollution degree                      | 2                                      |
| Ambient air temperature for operation | -10...60 °C                            |
| IP degree of protection               | IP20 conforming to IEC/EN 61010-2-201  |
| Relative humidity                     | 10...95 % non-condensing               |
| Operating altitude                    | 0...2000 m                             |
| Storage altitude                      | 0...3000 m                             |
| Vibration resistance                  | 3M4 on 35 x 15 mm symmetrical DIN rail |

## Packing Units

|                              |         |
|------------------------------|---------|
| Unit Type of Package 1       | PCE     |
| Number of Units in Package 1 | 1       |
| Package 1 Weight             | 172.0 g |
| Package 1 Height             | 7.4 cm  |
| Package 1 width              | 10.4 cm |
| Package 1 Length             | 12.4 cm |
| Unit Type of Package 2       | S03     |
| Number of Units in Package 2 | 18      |
| Package 2 Weight             | 3.75 kg |
| Package 2 Height             | 30.0 cm |
| Package 2 width              | 30.0 cm |
| Package 2 Length             | 40.0 cm |

## Offer Sustainability

|                            |  |
|----------------------------|--|
| Sustainable offer status   | Green Premium product  |
| REACH Regulation           | <a href="#">REACH Declaration</a>  |
| EU RoHS Directive          | Pro-active compliance (Product out of EU RoHS legal scope) <a href="#">EU RoHS Declaration</a> |
| Mercury free               | Yes  |
| RoHS exemption information | <a href="#">Yes</a>  |
| China RoHS Regulation      | <a href="#">China RoHS Declaration</a>   |
| Environmental Disclosure   | <a href="#">Product Environmental Profile</a>  |
| Circularity Profile        | <a href="#">End Of Life Information</a>  |
| PVC free                   | Yes  |

## Contractual warranty

|          |           |
|----------|-----------|
| Warranty | 18 months |
|----------|-----------|

---

Dimensions

---

Side and Front Views

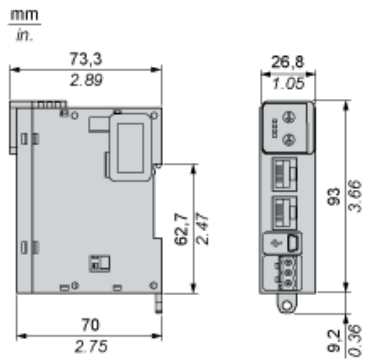

## Spacing Requirements

