



FUSELESS LOAD FEEDER REVERSING OPERATION, 400 V AC, SZ S00, 0.14 TO 0.20 A, 24 V DC SCREW TERMINAL FOR STANDARD RAIL MOUNTING, TYPE OF COORDINATION 2, IQ =150 KA (ALSO FULFILLS TYPE OF COORDINATION 1) 1NC (CONTACTOR)

product brand name		SIRIUS
Product designation		non-fused load feeders 3RA2
Manufacturer article number		
<ul style="list-style-type: none"> • of the supplied contactor • of the supplied circuit-breakers • of the supplied link module 		3RT2015-1BB42 3RV2011-0BA10 3RA1921-1DA00

General technical data:

Insulation voltage		
<ul style="list-style-type: none"> • with degree of pollution 3 Rated value 	V	690
Shock resistance		
<ul style="list-style-type: none"> • acc. to IEC 60068-2-27 		6g / 11 ms
Surge voltage resistance Rated value	kV	6
Type of assignment		2
Protection class IP		
<ul style="list-style-type: none"> • on the front 		IP20

Main circuit:

Number of poles for main current circuit		3
Adjustable response value current of the current-dependent overload release	A	0.14 ... 0.2
Operating voltage		
<ul style="list-style-type: none"> • Rated value • at AC-3 Rated value maximum 	V	690
	V	690
Operating frequency Rated value	Hz	50 ... 60
Operating current		
<ul style="list-style-type: none"> • at AC-3 		

— at 400 V Rated value	A	0.2
Operating power		
• at AC-3		
— at 400 V Rated value	W	60
— at 500 V Rated value	W	60
— at 690 V Rated value	W	90

Control circuit/ Control:

Control supply voltage for DC		
• Rated value	V	24
Holding power of the magnet coil for DC	W	4

Auxiliary circuit:

Product expansion Auxiliary switch		Yes
---	--	-----

Protective and monitoring functions:

Trip class		CLASS 10
Design of the overload circuit breaker		thermal (bimetallic)

UL/CSA ratings:

Full-load current (FLA) for three-phase AC motor		
• at 480 V Rated value	A	0.2

Short-circuit:

Product function Short circuit protection		Yes
Design of the short-circuit trip		magnetic
Conditional short-circuit current (I_q)		
• at 690 V acc. to IEC 60947-4-1 Rated value	A	100 000
• at 400 V acc. to IEC 60947-4-1 Rated value	A	153 000
• at 500 V acc. to IEC 60947-4-1 Rated value	A	100 000

Installation/ mounting/ dimensions:

mounting position		vertical
Mounting type		screw and snap-on mounting onto 35 mm standard mounting rail
Height	mm	170
Width	mm	90
Depth	mm	97.1
Required spacing		
• for grounded parts		
— forwards	mm	0
— Backwards	mm	0
— upwards	mm	20
— at the side	mm	9
— downwards	mm	10
• for live parts		

— forwards	mm	0
— Backwards	mm	0
— upwards	mm	20
— downwards	mm	10
— at the side	mm	9

Connections/ Terminals:

Type of electrical connection

- for main current circuit

screw-type terminals

Safety related data:

B10 value with high demand rate acc. to SN 31920

1 000 000

Proportion of dangerous failures

- with high demand rate acc. to SN 31920

%

73

Protection against electrical shock

finger-safe

Mechanical data:

Size of the circuit-breaker

S00

Size of load feeder

S00

Ambient conditions:

Ambient temperature

- during operation
- during storage
- during transport

°C

-20 ... +60

°C

-50 ... +80

°C

-50 ... +80

Certificates/ approvals:

General Product Approval	For use in hazardous locations	Declaration of Conformity	Test Certificates
--------------------------	--------------------------------	---------------------------	-------------------



[Special Test Certificate](#)

Test Certificates	Shipping Approval
-------------------	-------------------

[Declaration of the Compliance with the order](#)

[Type Test Certificates/Test Report](#)



GL

Shipping Approval	other
-------------------	-------



[Environmental Confirmations](#)

[Declaration of Conformity](#)

[other](#)

Further information

Information- and Downloadcenter (Catalogs, Brochures,...)

<http://www.siemens.com/industrial-controls/catalogs>

Industry Mall (Online ordering system)

<http://www.siemens.com/industrymall>

Cax online generator

<http://support.automation.siemens.com/WW/CAXorder/default.aspx?lang=en&mfb=3RA22100BA152BB4>

Service&Support (Manuals, Certificates, Characteristics, FAQs,...)

<http://support.automation.siemens.com/WW/view/en/3RA22100BA152BB4/all>

Image database (product images, 2D dimension drawings, 3D models, device circuit diagrams, EPLAN macros, ...)

http://www.automation.siemens.com/bilddb/cax_de.aspx?mfb=3RA22100BA152BB4&lang=en

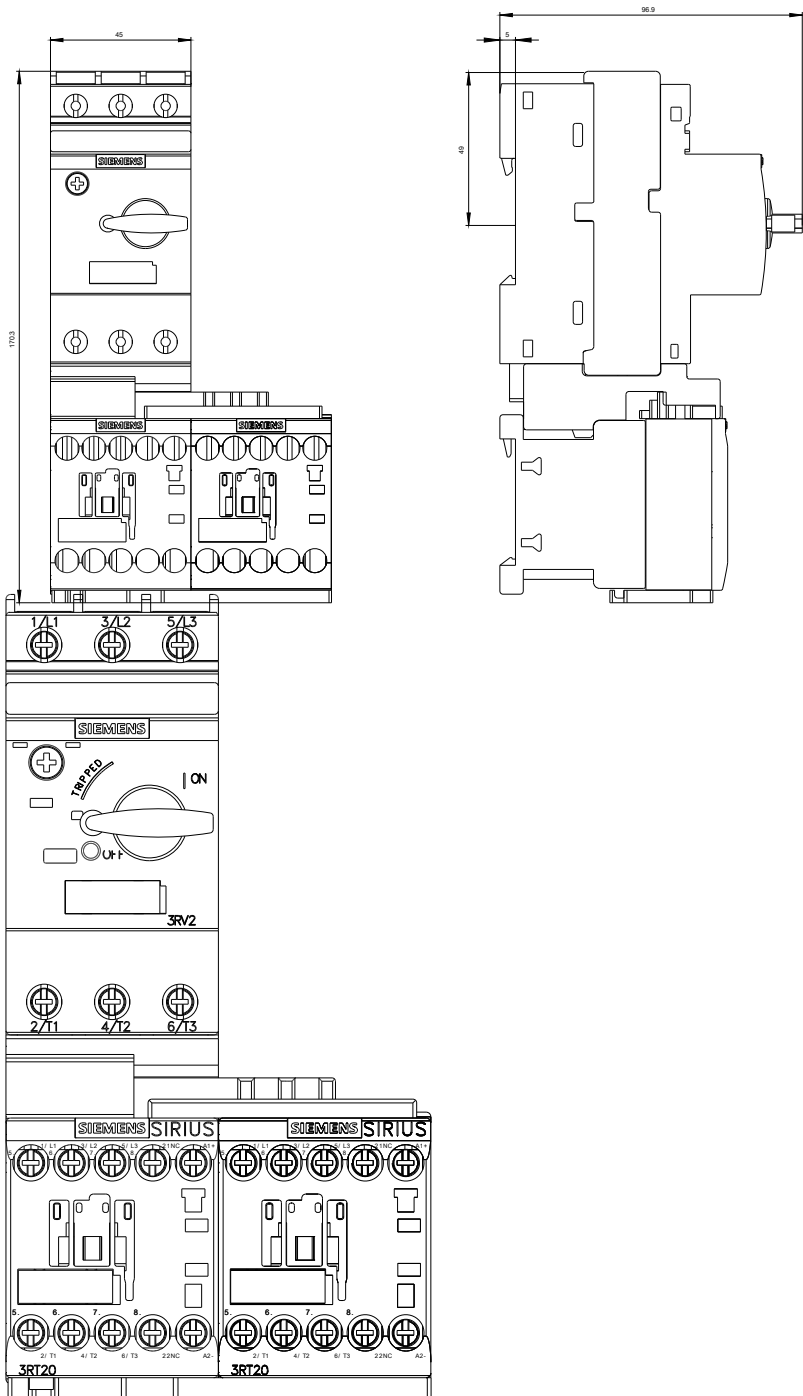

REBR&REBEF&ZV&C&DHERUNGSL.

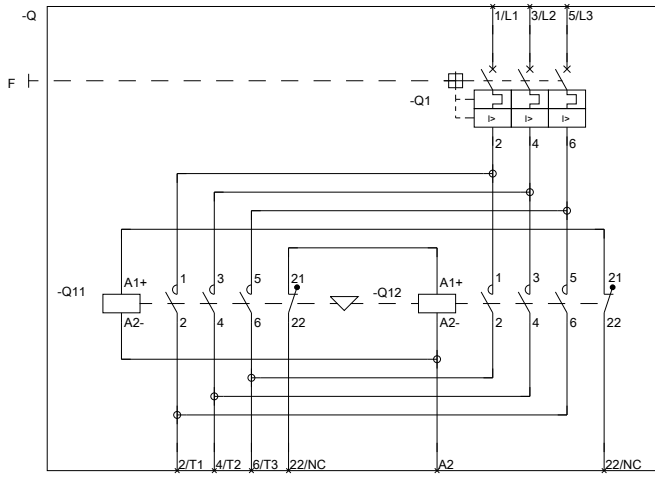

REBR&REBEF&ZV&C&DHERUNGSL.

last modified:

11.03.2015