

RFI Shield Clips

Shield Clips for EMI/RFI Shields

- ❖ SMT devices offering a fast solution for assembling RFI shields to PCBs.
- ❖ Eliminates the need for through holes and post reflow operations.
- ❖ Saves PCB real estate.
- ❖ Facilitates easy removal of the can for maintenance and repair.
- ❖ Substantial improvement in time and simplicity of assembly tuning and re-work.

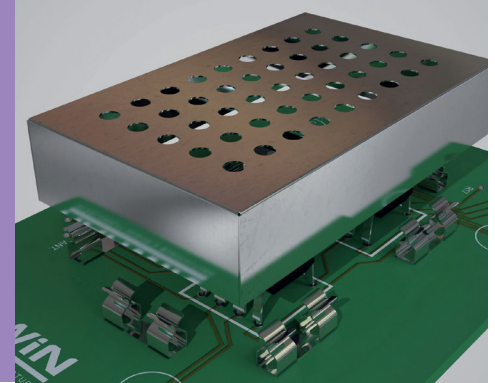

SPECIFICATION	Part No.	Type	Shield Thickness	Material	Finish	Pack Qty. on Ø330mm reel	Insertion Force (max)	Withdrawal Force (min)
	S1411-46R	Maxi	0.70-1.00mm	Beryllium Copper	Tin	1,900	7N	0.8N
	S1711-46R	Midi	0.17-0.30mm	Beryllium Copper	Tin	1,900	4N	0.5N
	S2711-46R	Midi	0.17-0.30mm	Cupro-Nickel (Beryllium-free)	Tin	1,900	4N	0.5N
	S0971-46R	Mini	0.20-0.30mm	Stainless Steel	Tin	5,000	19.6N	0.98N
	S1721-46R	Mini	0.13-0.23mm	Beryllium Copper	Tin	5,000	5N	0.35N
	S0941-46R	Micro	0.15-0.20mm	Stainless Steel	Tin	10,000	9.8N	0.69N
	S0951-46R	Micro	0.20mm	Stainless Steel	Tin	10,000	9.8N	0.69N
	S0961-46R	Micro	0.15-0.20mm	Stainless Steel	Tin	10,000	24.5N	0.98N
	S0991-46R	Micro	0.20-0.25mm	Stainless Steel	Tin	15,000	19.6N	0.98N
	S1001-46R	Micro	0.15-0.20mm	Stainless Steel	Tin	20,000	19.6N	0.98N
S0981-46R	Corner	0.20-0.25mm	Stainless Steel	Tin	6,000	19.6N	0.98N	

MAXI & MIDI

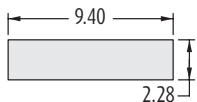
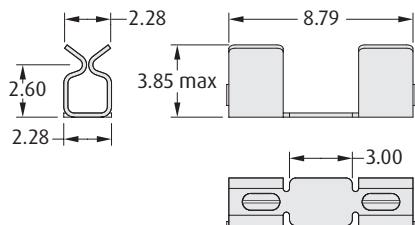

Recommended PC Board Pattern

ORDER CODE	TYPE	MATERIAL
S1411-46R	Maxi	Beryllium Copper
S1711-46R	Midi	Beryllium Copper
S2711-46R	Midi	Cupro-Nickel

MINI

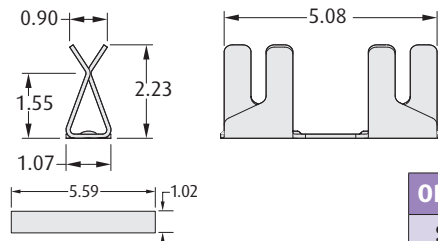

Recommended PC Board Pattern

ORDER CODE
S1721-46R

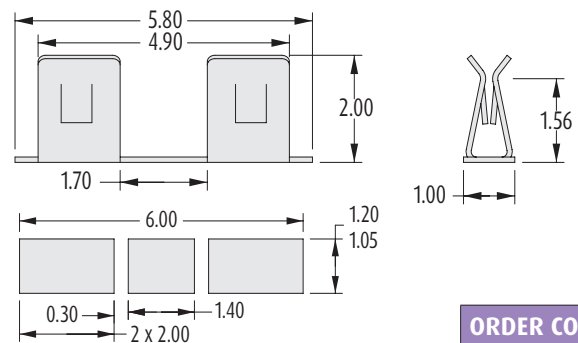

Recommended PC Board Pattern

ORDER CODE
S0971-46R

All dimensions in mm.

RFI Shield Clips

Shield Clips for EMI/RFI Shields

- Compatible with industry standard placement machines.
- Packaged in standard (EIA 481) Tape & Reel format.
- Spring contact design provides secure retention.
- Ideally suited to miniature electronics.
- Low profile and right angle clips offer design flexibility.

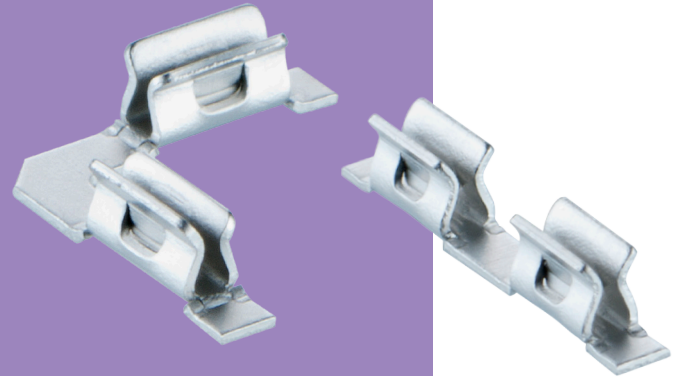

<p>MICRO</p>	<p>MICRO</p>								
<p>Recommended PC Board Pattern</p> <table border="1"> <thead> <tr> <th>ORDER CODE</th> <th>FINISH</th> </tr> </thead> <tbody> <tr> <td>S0941-46R</td> <td>Tin </td> </tr> </tbody> </table>	ORDER CODE	FINISH	S0941-46R	Tin	<p>Recommended PC Board Pattern</p> <table border="1"> <thead> <tr> <th>ORDER CODE</th> <th>FINISH</th> </tr> </thead> <tbody> <tr> <td>S0951-46R</td> <td>Tin </td> </tr> </tbody> </table>	ORDER CODE	FINISH	S0951-46R	Tin
ORDER CODE	FINISH								
S0941-46R	Tin								
ORDER CODE	FINISH								
S0951-46R	Tin								
<p>MICRO</p>	<p>MICRO</p>								
<p>Recommended PC Board Pattern</p> <table border="1"> <thead> <tr> <th>ORDER CODE</th> <th>FINISH</th> </tr> </thead> <tbody> <tr> <td>S0961-46R</td> <td>Tin </td> </tr> </tbody> </table>	ORDER CODE	FINISH	S0961-46R	Tin	<p>Recommended PC Board Pattern</p> <table border="1"> <thead> <tr> <th>ORDER CODE</th> <th>FINISH</th> </tr> </thead> <tbody> <tr> <td>S0991-46R</td> <td>Tin </td> </tr> </tbody> </table>	ORDER CODE	FINISH	S0991-46R	Tin
ORDER CODE	FINISH								
S0961-46R	Tin								
ORDER CODE	FINISH								
S0991-46R	Tin								
<p>MICRO</p>	<p>CORNER</p>								
<p>Recommended PC Board Pattern</p> <table border="1"> <thead> <tr> <th>ORDER CODE</th> <th>FINISH</th> </tr> </thead> <tbody> <tr> <td>S1001-46R</td> <td>Tin </td> </tr> </tbody> </table>	ORDER CODE	FINISH	S1001-46R	Tin	<p>Recommended PC Board Pattern</p> <table border="1"> <thead> <tr> <th>ORDER CODE</th> <th>FINISH</th> </tr> </thead> <tbody> <tr> <td>S0981-46R</td> <td>Tin </td> </tr> </tbody> </table>	ORDER CODE	FINISH	S0981-46R	Tin
ORDER CODE	FINISH								
S1001-46R	Tin								
ORDER CODE	FINISH								
S0981-46R	Tin								

All dimensions in mm.