

Airflow 3[™]

SACHET 600ml

A single component pneumatic bead applicator for sachets



Floating plunger system to minimise waste of material.

Ergonomically designed handle for comfort.

Variable speed regulator for precise control and smooth material flow.

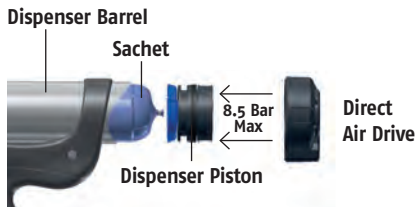

PRODUCT FEATURES:

- 6.8bar (100psi) regulator as standard (others available).

Standard: 6.8 bar (100 psi) ●
Options available: 3.4 bar (50 psi) ●
 5.2 bar (75 psi) ●
 8.5 bar (125 psi) ○

- Tool for larger volume materials.

- Built-in silencer (less than 70dB) for user-friendly environment.

COMPRESSOR GUIDE



The **Cox Airflow 3** is part of a range of mid-powered pneumatic applicators. Designed for use with low to medium viscosity sealants and adhesives, the Airflow 3 is ideal for professional and semi-professional users.

For more information call +44(0)1635 264500
Or visit www.pccox.co.uk



The original

TECHNICAL DATASHEET

Airflow 3™ SACHET 600ml



A single component pneumatic bead applicator for sachets

APPLICATIONS:

- For low to medium viscosity
- Sachet volumes: 310ml, 400ml, 600ml

SPECIFICATIONS:

- Max Pneumatic Pressure: 6.8bar (100psi) (others available)
- Barrel Length: 436.2mm
- Maximum Thrust: 1.5kN
- Tool Weight: 820g
- Tool Material: Glass filled nylon handle, anodised aluminium barrel
- Certificates: ISO, REACH, CE, EN
- Packaging Options: 1 per box

WEB LINKS:

- Academy video
www.pccox.co.uk/en/cox-academy
- Spare parts diagram
www.pccox.co.uk/en/exploded-diagrams

OTHER MODELS AVAILABLE:

- Airflow 3 Compact Combi
- Airflow3 Cartridge
- Airflow 3 Combi
- Airflow 3 Combi HP

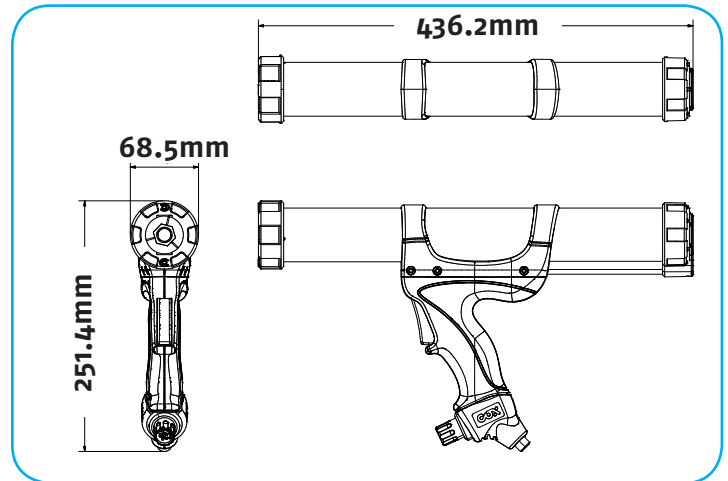

SACHETS:

310ml:



400ml:



600ml:



PRODUCT RANGE BY POWER:



PC Cox Ltd., Turnpike Road, Newbury, Berkshire, RG14 2LR
 T Sales +44 (0) 1635 264500 F +44 (0) 1635 264555
 E sales@pccox.co.uk
 www.pccox.co.uk



©PC Cox Ltd. 2014. Cox is a trademark of PC Cox Ltd. Every effort has been made to ensure that the information contained in this leaflet was correct at the time of going to press. However, the company retains the right to change any specification without notice, in line with the company's policy of continual product development.