

NOTES:

- 1. MATERIALS OF CONSTRUCTION:
 SHELL, BODY/FLANGE, & CONTACT BODY = BRASS, SILVER PLATED
 CONTACT PIN = BRASS, GOLD PLATED
 RETAINER RING = STAINLESS STEEL, NATURAL
 INSULATOR = TEFLON PER MIL-P-19468
 GASKET = SILICONE RUBBER, COLOR RED

49000-SRFX		REVISIONS			
DRAWING NO.	REV	DESCRIPTION	DATE	ECO	APPR
THIRD ANGLE PROJ.	A	RELEASE TO MFG.	4/13/00	43308	CPM

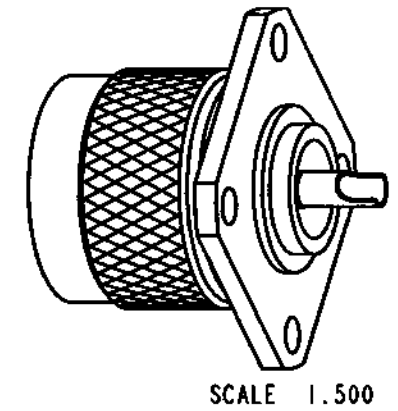
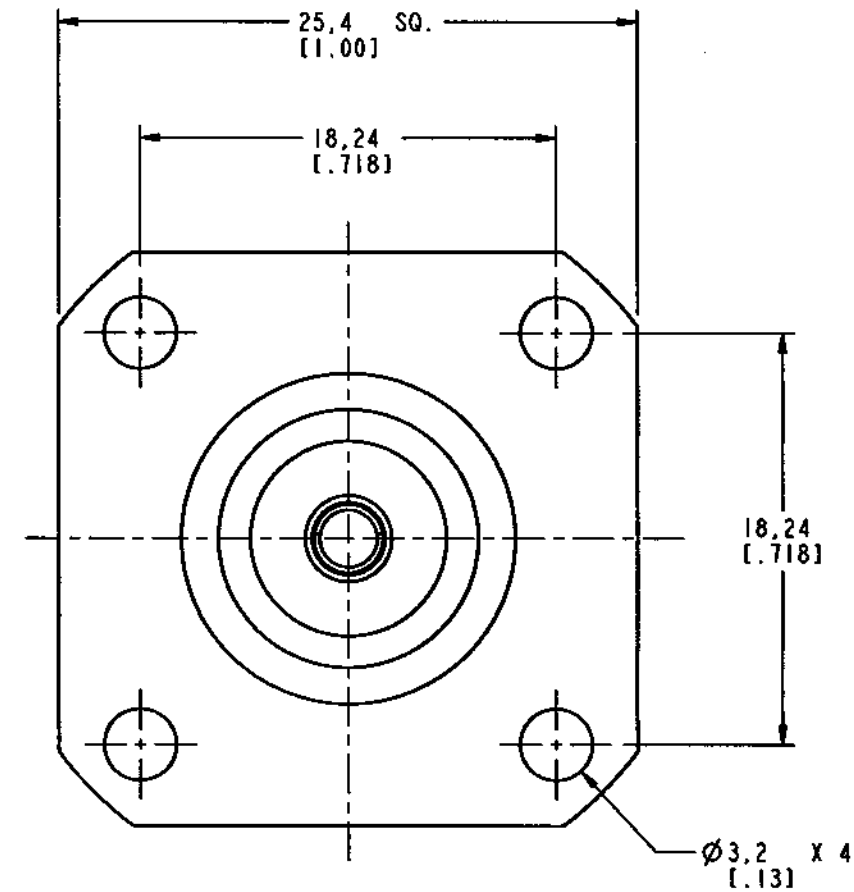
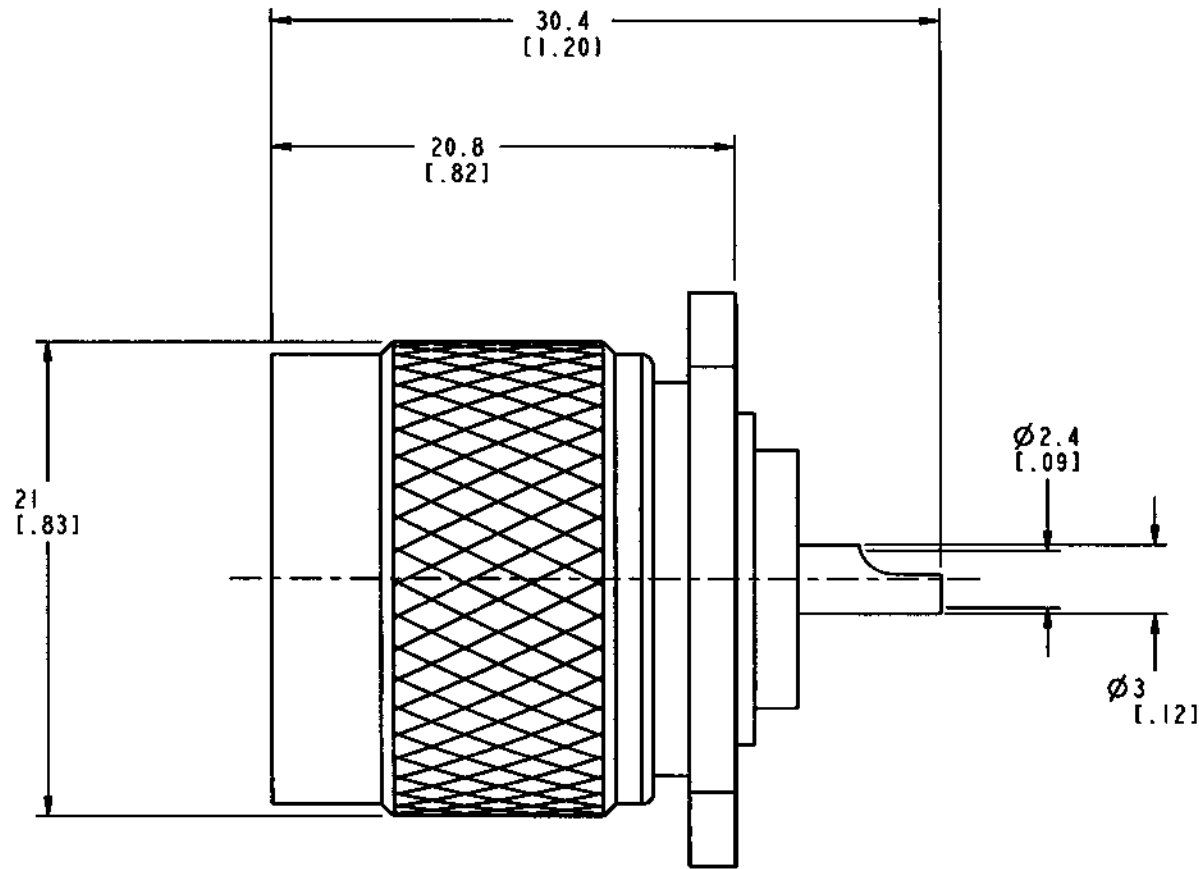

CUSTOMER OUTLINE DRAWING
FOR REFERENCE ONLY

UNLESS OTHERWISE SPECIFIED, DIMENSIONS ARE IN INCHES AND TOLERANCES ARE: 0.5 - 6mm ±0.2mm 6 - 30mm ±0.4mm 30 - 120mm ±0.6mm	MATERIAL	DRAWN C. McGRATH	DATE 30-Mar-00	TITLE 'N' PANEL RECEPTACLE PLUG	Amphenol Amphenol Corporation Communication and Network Products Division Danbury, CT U.S.A. 06810
	REFERENCE EAR 967457-0 GEN# 49000-SRFX_ASSY	ENGINEER T. AUBIN	DATE 30-Mar-00		
NOTICE - These drawings, specifications, or other data (1) are, and remain the property of Amphenol Corp. (2) must be returned upon request; and (3) are confidential and not to be disclosed to any person other than those to whom they are given by Amphenol Corp. The furnishing of these drawings, specifications, or other data by Amphenol Corp., or to any other person to anyone for any purpose is not to be regarded by implication or otherwise in any manner licensing, granting rights or permitting such holder or any other person to manufacture, use or sell any product, process or design, patented or otherwise, that may in any way be related to or disclosed by said drawings, specifications, or other data.		APPROVED <i>T. Aubin</i>	DATE 4/12/00	CODE ID 74868	DWG SIZE B
		CAD FILE I:\N\49000-SRFX	DRAWING NO. 49000-SRFX	REV A	