

W Union elbow

EO 24° cone end

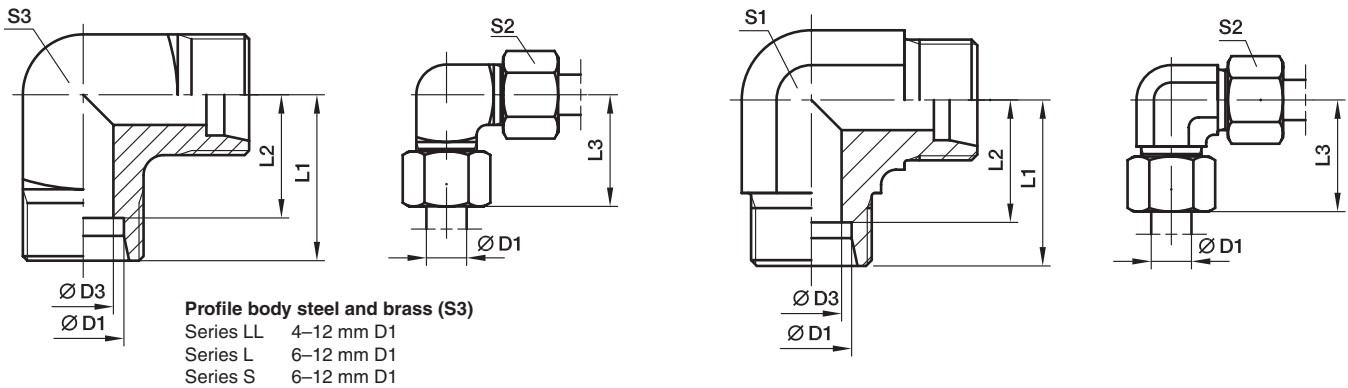

Series	D1	D3	L1	L2	L3	S1	S2	S3	Weight g/1 piece	Order code*	PN (bar) ¹⁾		
											CF	71	MS
LL ²⁾	04	3.0	15	11.0	21	9	10	9	13	W04LL	100	100	63
	06	4.5	15	9.5	21	9	12	11	15	W06LL	100	100	63
	08	6.0	17	11.5	23	12	14	12	23	W08LL	100	100	63
	10	8.0	18	12.5	24	12	17	14	32	W10LL	100	100	63
	12	10.0	19	13.0	25	14	19	17	41	W12LL	100	100	63
L ³⁾	06	4.0	19	12.0	27	12	14	12	29	W06L	500	315	200
	08	6.0	21	14.0	29	12	17	14	43	W08L	500	315	200
	10	8.0	22	15.0	30	14	19	17	54	W10L	500	315	200
	12	10.0	24	17.0	32	19	22		80	W12L	400	315	200
	15	12.0	28	21.0	36	19	27		81	W15L	400	315	200
	18	15.0	31	23.5	40	24	32		140	W18L	400	315	200
	22	19.0	35	27.5	44	27	36		178	W22L	250	160	100
	28	24.0	38	30.5	47	36	41		340	W28L	250	160	100
	35	30.0	45	34.5	56	41	50		458	W35L	250	160	100
	42	36.0	51	40.0	63	50	60		776	W42L	250	160	100
S ⁴⁾	06	4.0	23	16.0	31	12	17	14	52	W06S	800	630	400
	08	5.0	24	17.0	32	14	19	17	74	W08S	800	630	400
	10	7.0	25	17.5	34	19	22		97	W10S	800	630	400
	12	8.0	29	21.5	38	17	24	22	137	W12S	630	630	400
	14	10.0	30	22.0	40	19	27		145	W14S	630	630	400
	16	12.0	33	24.5	43	24	30		162	W16S	630	400	250
	20	16.0	37	26.5	48	27	36		221	W20S	420	400	250
	25	20.0	42	30.0	54	36	46		424	W25S	420	400	250
	30	25.0	49	35.5	62	41	50		603	W30S	420	400	250
	38	32.0	57	41.0	72	50	60		1010	W38S	420	315	200

¹⁾ Pressure shown = item deliverable

²⁾ LL = very light series; ³⁾ L = light series; ⁴⁾ S = heavy series

$$\frac{\text{PN (bar)}}{10} = \text{PN (MPa)}$$

Delivery without nut and ring. Information on ordering complete fittings see page I7.

*Please add the **suffixes** below according to the material/surface required.

Order code suffixes		
Material	Suffix surface and material	Example
Steel, zinc plated, Cr(VI)-free	CFX	W16SCFX
Stainless Steel	71X	W16S71X
Brass	MSX	W16SMSX