

Classic OPzS blocks / 6V 6 OPzS 300 LA

INDUSTRIAL BATTERIES / NETWORK POWER

Classic OPzS batteries have been proven energy suppliers for decades, which convince in robustness, reliability and extremely long design- or cycle life.

Part Number: NVZS060300WC0FB

APPLICATIONS



SPECIFICATIONS

- Very high operational reliability under rough operating conditions
- Low maintenance due to optimised alloy and large electrolyte reserve
- 20 years design life at 20 °C ambient temperature (80 % remaining capacity from C₁₀)
- Container made from high quality translucent plastics
- Also available in dry charged condition with separate electrolyte
- Low gassing acc. to EN 50272-2 thanks to the low antimony alloy (< 3%)
- Designed in accordance with IEC 60896-11, DIN 40736 and DIN 40737 T3
- Electrolyte: diluted sulphuric acid dN = 1.24 kg/l
- Manufactured in Europe in our ISO 9001 certified production plants



Design life
20 years



Block battery



Tubular plate



Recyclable



Low
maintenance

RECYCLE WITH EXIDE.



Exide Technologies takes pride in its commitment to a better environment. An integrated approach to manufacturing, distributing and recycling of lead-acid batteries has been developed to ensure a safe and responsible life cycle for all of its products.



For more information please
[contact your local dealer](#)

TECHNICAL CHARACTERISTICS AND DATA

Nominal voltage	6 V
Float charge	2,23 V/C @ 20 °C
Capacity	CC 10h 1,8V/C 20°C 300Ah
Short circuit current	3106 A (IEC60896-21/22)
Internal resistance	1,96 mΩ (IEC60896-21/22)
Electrolyte density	1,24 kg/l

Terminal	F-M8
Terminal Torque	12 Nm
Container	PP (Polypropylene)
Temperature range	-20°C to 55°C
Dimensions (l x b/w x h)	380 x 206 x 347 mm
Weight	63 kg
Acid weight	20 kg
Origin	La Cartuja, Spain

CONSTANT CURRENT DISCHARGE

A @ 20 °C	5 min	10 min	15 min	30 min	1 h	2 h	3 h	4 h	5 h	6 h	8 h	10 h
1,900 V/C	160	147	136	118	91	66	53	45,3	39	34	28	24,5
1,870 V/C	195	176	160	135	104	76,5	59,2	51	44	38	32	27
1,850 V/C	216	195	177	147	114	79	62	54	46	40,5	33,7	28
1,830 V/C	237	213	195	160	123	85,7	66,3	56,5	48,3	42,5	34,8	29
1,800 V/C	260	240	218	177	135	89,3	70,4	59,5	51	44,5	35,8	30,3
1,750 V/C	340	295	260	200	143	98,3	76,7	62	52,5	45,8	36,8	30,6
1,700 V/C	380	333	295	220	159	103	77	63,6	53,5	46,4	37,3	31,2
1,670 V/C	417	355	315	231	163	105	78	64,1	54	46,6	37,5	31,3
1,650 V/C	435	369	326	237	165	106	78,5	64,4	54,2	46,8	37,6	31,3

Technical drawing

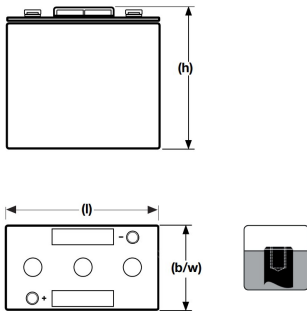

Float Voltage vs Temperature

