

## 3.5W CONVECTION COOLED

DC-DC CONVERTER

The JMR03 family of ultra-compact, medically approved, 4:1 input devices provide 2 x MOPP and can be used in BF and CF rated applications with just 2µA leakage current. The ultra-small DIP16 module saves 45% of PCB area and the no load input idle current is greatly reduced giving longer run time in portable battery powered applications.



### Features

- Regulated Single & Dual Outputs
- World Wide Medical Certification
- 4:1 Input Range
- Compact DIP16 Package
- 5.0kVAC Isolation
- 2 x MOPP at 250VAC Working Voltage
- Remote On/Off
- -40°C to +100°C Operation
- 3 Year Warranty

### Applications



Healthcare



Home Healthcare



Medical Diagnostics

### Dimensions

0.96 x 0.58 x 0.43" (24.4 x 14.7 x 10.8mm)

### Models & Ratings

Model Number	Input Voltage	Output Voltage <sup>(1)</sup>	Output Current	Input Current		Maximum Capacitive Load
				No Load	Full Load	
JMR0312S05	12V (4.5-18V)	5V	700mA	25mA	374mA	1470µF
JMR0312S12		12V	292mA	50mA	352mA	470µF
JMR0312S15		15V	234mA	45mA	352mA	330µF
JMR0312D12		±12V (24V)	±146mA	50mA	356mA	±220µF
JMR0312D15		±15V (30V)	±117mA	60mA	356mA	±160µF
JMR0324S05	24V (9.0-36.0V)	5V	700mA	20mA	185mA	1470µF
JMR0324S12		12V	292mA	25mA	174mA	470µF
JMR0324S15		15V	234mA	30mA	176mA	330µF
JMR0324D12		±12V (24V)	±146mA	30mA	174mA	±220µF
JMR0324D15		±15V (30V)	±117mA	30mA	176mA	±160µF
JMR0348S05	48V (18.0-75.0V)	5V	700mA	15mA	94mA	1470µF
JMR0348S12		12V	292mA	15mA	89mA	470µF
JMR0348S15		15V	234mA	20mA	89mA	330µF
JMR0348D12		±12V (24V)	±146mA	20mA	92mA	±220µF
JMR0348D15		±15V (30V)	±117mA	20mA	91mA	±160µF

#### Notes:

1. Dual output models can be used to provide a single output of 24V or 30V.
2. Specifications noted using nominal input voltage and full load at 25°C unless otherwise stated.

## Input

Characteristic	Minimum	Typical	Maximum	Units	Notes & Conditions
Input Voltage Range	4.5		18	VDC	12V nominal
	9		36		24V nominal
	18		75		48V nominal
Inrush Current			28	A	
Input Reflected Ripple		20		mA pk-pk	Through 12μH inductor and 47μF capacitor
Input Surge			25	VDC for 100ms	12V nominal
			50		24V nominal
			100		48V nominal
Input Current Remote On/Off		2.5	3.0	mA	Idle current using remote "Off". See models and ratings table for no load input current with module "On"
Recommended Input Fuse (Slow blow)		2.0		A	12V nominal
		1.0			24V nominal
		0.8			48V nominal

## Output

Characteristic	Minimum	Typical	Maximum	Units	Notes & Conditions
Output Voltage	5		30	VDC	See Models & Ratings table
Initial Set Accuracy			±1	%	At full load
Minimum Load	0			%	No minimum load required
Line Regulation			±0.5	%	From min to max input voltage
Load Regulation			±1.0	%	From 0-100% load
Cross Regulation			±5	%	Dual output, when one output at 25% load other is varied from 10% to full load
Transient Response Deviation	3		5	%	Deviation recovering to within 1% in 500μs for 25% load change at 0.1A/μs
Ripple & Noise			75	mV pk-pk	20MHz bandwidth. Measured using 0.1μF ceramic capacitor
Short Circuit Protection	Continuous, with auto recovery				
Maximum Capacitive Load	See Models & Ratings table				
Temperature Coefficient			0.02	%/°C	
Overload Protection	115		165	%	Of output current at nominal input voltage
Remote On/Off	Output is on if remote on/off (pin 2) is open Output turns off if 2-4mA is applied to remote On/Off (pin 2). See application note				

## General

Characteristic	Minimum	Typical	Maximum	Units	Notes & Conditions
Efficiency		82		%	See Models & Ratings table
Isolation: Input to Output	5000			VAC	Reinforced insulation, 2 x MOPP, 60s
Working Voltage			250/400	VAC/VDC	
Creepage and Clearance	8			mm	
Isolation Resistance	10 <sup>9</sup>			Ω	Input to output
Isolation Capacitance		10	20	pF	Input to output
Leakage Current			2	μA	264VAC, 60Hz
Power Density			14.6	Win <sup>3</sup>	
Mean Time Between Failure	776			khrs	MIL-HDBK-217F, +25°C GB
Switching Frequency	100		600	kHz	
Weight		0.016 (7.27)		lb (g)	
Solder Profile			260	°C	Waveflow. 0.05" (1.5mm) from case, 10 seconds max.
Case Material	Non conductive black plastic UL94V-0 rated				
Potting Material	Silicone, UL94V-0 rated				
Pin Material	Solder coated brass dia. 0.5mm				
Water Wash	Use deionized water. Dry thoroughly				

## Environmental

Characteristic	Minimum	Typical	Maximum	Units	Notes & Conditions
Operating Temperature	-40		+90	°C	See derating curve
Storage Temperature	-55		+125	°C	
Case Temperature			+105	°C	
Humidity Operating & Storage	5		95	%RH	Non-condensing
Cooling	Natural convection				
Operating Altitude			5000	m	Transport altitude 10km
Temperature Coefficient		±0.03		%/°C	

## Safety Approvals

Safety Agency	Standard	Notes & Conditions
UL	ANSI/AAMI ES60601-1, UL62368-1	
CSA	CSA C22.2 No. 60601-1	
TUV	EN60601-1	
CB	IEC/EN60601-1	
CE	Meets all applicable directives	
UKCA	Meets all applicable legislation	

## EMC: Emissions

Phenomenon	Standard	Test Level	Notes & Conditions
Conducted	EN55011	Class B	See application notes
Radiated	EN55011	Class B	

## EMC: Immunity

Phenomenon	Standard	Test Level	Criteria	Notes & Conditions
Medical Device EMC	EN60601-1-2: 2015			
ESD Immunity	EN61000-4-2	±8kV	A	Air
		±15kV		Contact
Radiated Immunity	EN61000-4-3	10V/m	A	
EFT/Burst	EN61000-4-4	±2kV	A	External input capacitor required 330µF/100V
Surge	EN61000-4-5	±2kV	A	External input capacitor required 330µF/100V
Conducted Immunity	EN61000-4-6	10Vrms	A	
Magnetic Fields	EN61000-4-8	100A/m	A	

## Mechanical Details

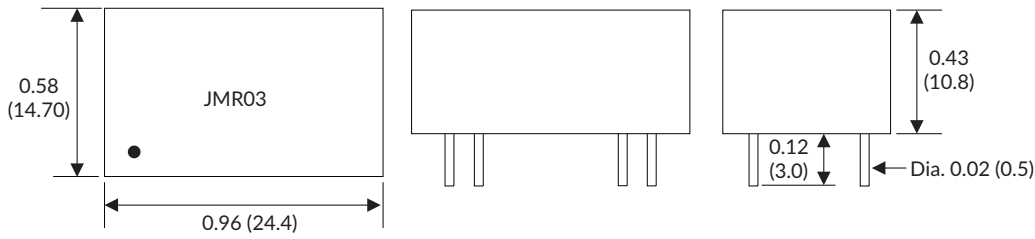

Pin Connections		
Pin	Single	Dual
1	-Vin	-Vin
2	CTRL	CTRL
8	NC	Common
9	+Vout	+Vout
10	-Vout	-Vout
16	+Vin	+Vin

### Recommended PCB Footprint

There should be at least 8mm distance between primary and secondary circuit.

- Through hole diameter 0.031" (0.8mm)
- Pad diameter top side 0.039" (1.0mm)
- Pad diameter bottom side 0.079" (2.0mm)

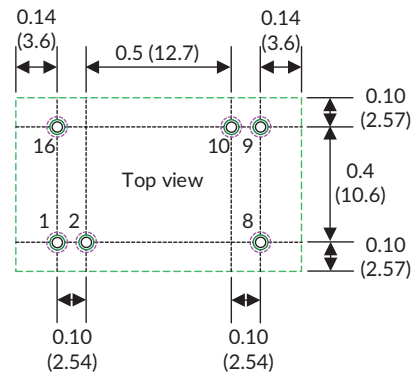
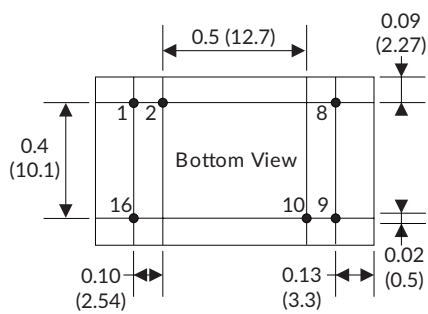

### Notes:

- All dimensions are in inches (mm)
- Weight: 0.016 (7.27) lbs (g) approx.
- Pin diameter: 0.02±0.002 (0.5±0.05)
- Pin pitch tolerance: ±0.014 (±0.35)
- Case tolerance: ±0.02 (±0.5)

## Application Notes

### EFT and EMC Class B Circuitry

Circuit **1** for Surge & EFT, **2** for EMC class B.

#### Single Output

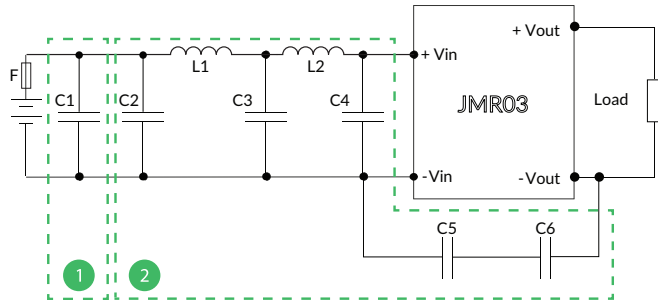

#### Dual Output

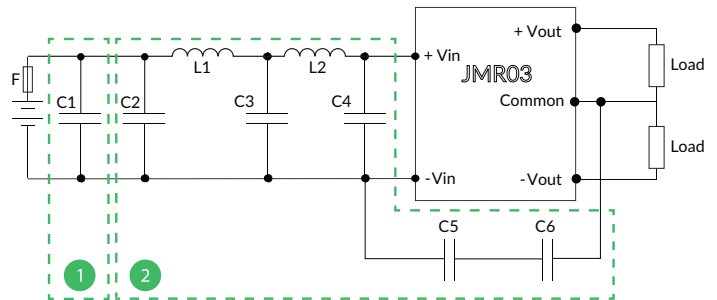

Model Number	Fuse (Slow Blow)	C1	C2, C3, C4	C5	C6	L1	L2
JMR0312XXX	2.0A	NIPPON chemi-con KY series 220µF, 100V	MLCC, 22µF, 35V	68pF/400 VAC Y1	68pF/400 VAC Y1	2.2µF	2.2µF
JMR0324XXX	1.0A		MLCC, 10µF, 50V			33µF	33µF
JMR0348XXX	0.8A		MLCC, 4.7µF, 100V			4.7µF	4.7µF

### Remote On/Off

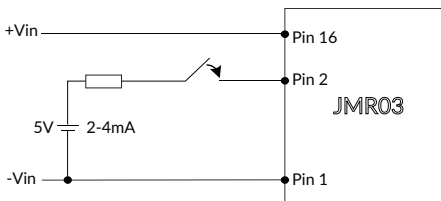

Module "On" if pin 2 is open circuit  
Module "Off" if connected to current source of 2-4mA

### Derating Curves

JMR0312S05, JMR0324S05, JMR0348S05,  
JMR0348D12, JMR0348D15

JMR0312S12, JMR0312S15, JMR0312D12, JMR0312D15,  
JMR0324S12, JMR0324S15, JMR0324D12, JMR0324D15,  
JMR0348S12, JMR0348S15

