

- 1
- 2
- 3
- 4
- 5
- 6
- 7
- 8
- 9
- 10
- 11
- 12
- 13
- 14
- 15
- 16
- 17
- 18

COVERING

Elastic rubber, hardness 70 Shore A

WHEEL CENTRE BODY

Pressure die-cast aluminium.

ROLLING ACTION

Hub with ball bearings. Ideal solution for heavy loads and continuous moving.

FIXED PLATE BRACKET

Yellow zinc-plated steel sheet. The bracket is designed to withstand loads up to 5000 N. It ensures capacities that make it suitable for heavy industrial applications.

TURNING PLATE BRACKET

Yellow zinc-plated steel sheet.

The presence of a double ball race and direct contact between the plate and the ball race ring with built-in pin ensure excellent manoeuvrability. Does not require maintenance. The bracket is designed to withstand loads up to 5000 N. It ensures capacities that make it suitable for heavy industrial applications.

It consists of (see Fig.1):

1. fitting plate: yellow zinc-plated steel sheet;
2. fork: yellow zinc-plated steel sheet;
3. ball race ring: yellow zinc-plated steel sheet;
4. central pin: class 8.8 steel screw and steel nut;
5. rotation system: dual grease-lubricated ball race;
6. dust seal: RAL 7015 dark grey technopolymer.

BRAKE

Dual-effect rear brake with simultaneous locking of wheel and bracket. The brake is simple and effective to use: it is actuated and released by a simple action from the top downward at the tip of two separate pedals, thus ensuring the utmost manoeuvring comfort. On wheels with a rear brake, the braking efficacy may be adjusted with a socket head screw M8.

STANDARD EXECUTIONS

- **PSL-H**: fixed plate bracket, without brake.
- **SSL-H**: turning plate bracket, without brake.
- **SSF-H**: turning plate bracket, with brake.

APPLICATIONS

Wear and tearing resistance. For further information see wheel technical data sheet RE.G2 (see page 1281).

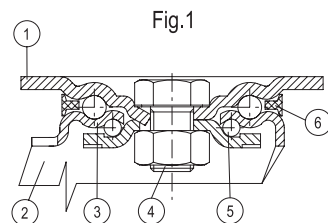

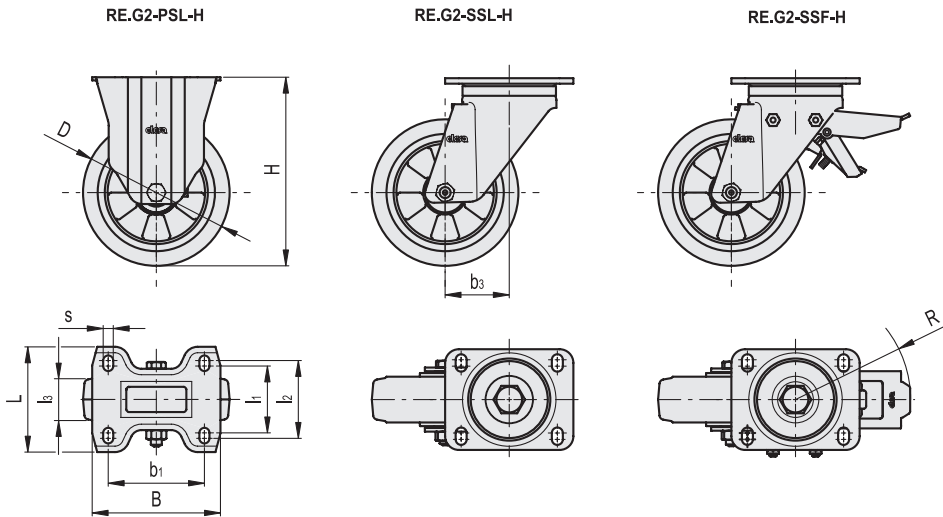

Code	Description	D	b1	l1	l2	l3	H	B	L	s	b3	R	Rolling resistance# [N]	Dynamic carrying capacity# [N]	
452785	RE.G2-100-PSL-H	100	80	60	-	40	138	100	85	9	-	-	1800	1800	810
452786	RE.G2-125-PSL-H	125	105	73	85	50	170	140	110	11	-	-	2300	2300	1660
452787	RE.G2-160-PSL-H	160	105	73	87	50	205	140	110	11	-	-	3000	3000	2080
452788	RE.G2-200-PSL-H	200	105	73	87	50	250	140	110	11	-	-	3000	5000	3000
452775	RE.G2-100-SSL-H	100	80	60	-	40	138	100	85	9	46	-	1800	1800	1310
452776	RE.G2-125-SSL-H	125	105	73	85	50	170	140	110	11	70	-	2300	2300	2300
452777	RE.G2-160-SSL-H	160	105	73	87	50	205	140	110	11	70	-	3000	3000	3570
452778	RE.G2-200-SSL-H	200	105	73	87	50	250	140	110	11	70	-	3000	5000	4460
452781	RE.G2-160-SSF-H	160	105	73	87	50	205	140	110	11	70	126	3000	3000	4140
452782	RE.G2-200-SSF-H	200	105	73	87	50	250	140	110	11	70	126	3000	5000	5060

For rolling resistance and dynamic carrying capacity see Technical data (on page 1296).