

T-Stutzen

EO 24° Anschluss

Profilkörper Stahl und Messing (S3)

Reihe LL 4–10 mm D1

Reihe L 6 + 8 mm D1

Reihe S 6 mm D1

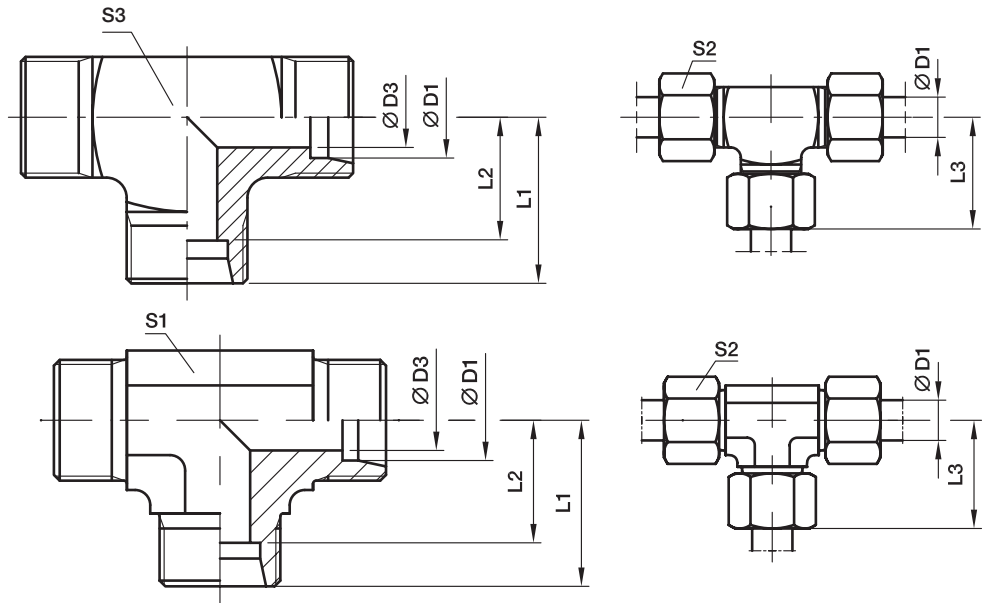

Bau- reihe	D1 	D3	L1	L2	L3	S1	S2	S3	Gewicht g/St.	Bestellzeichen*	PN (bar) ¹⁾		
											CF	71	MS
LL ²⁾	04	3,0	15	11,0	21	9	10	9	19	T04LL	100	100	63
	06	4,5	15	9,5	21	9	12	11	20	T06LL	100	100	63
	08	6,0	17	11,5	23	12	14	12	27	T08LL	100	100	63
	10	8,0	18	12,5	24	12	17	14	39	T10LL	100	100	63
	12	10,0	21	15,0	27	14	19		45	T12LL	100	100	63
L ³⁾	06	4,0	19	12,0	27	12	14	12	37	T06L	500	315	200
	08	6,0	21	14,0	29	12	17	14	53	T08L	500	315	200
	10	8,0	22	15,0	30	14	19		48	T10L	500	315	200
	12	10,0	24	17,0	32	17	22		65	T12L	400	315	200
	15	12,0	28	21,0	36	19	27		106	T15L	400	315	200
	18	15,0	31	23,5	40	24	32		179	T18L	400	315	200
	22	19,0	35	27,5	44	27	36		225	T22L	250	160	100
	28	24,0	38	30,5	47	36	41		396	T28L	250	160	100
	35	30,0	45	34,5	56	41	50		567	T35L	250	160	100
	42	36,0	51	40,0	63	50	60		905	T42L	250	160	100
S ⁴⁾	06	4,0	23	16,0	31	12	17	14	68	T06S	800	630	400
	08	5,0	24	17,0	32	14	19		70	T08S	800	630	400
	10	7,0	25	17,5	34	17	22		91	T10S	800	630	400
	12	8,0	29	21,5	38	17	24		117	T12S	630	630	400
	14	10,0	30	22,0	40	19	27		136	T14S	630	630	400
	16	12,0	33	24,5	43	24	30		202	T16S	630	400	250
	20	16,0	37	26,5	48	27	36		289	T20S	420	400	250
	25	20,0	42	30,0	54	36	46		545	T25S	420	400	250
	30	25,0	49	35,5	62	41	50		758	T30S	420	400	250
	38	32,0	57	41,0	72	50	60		1264	T38S	420	315	200

¹⁾ Druckwert genannt = Artikel lieferbar

²⁾ LL = Sehr leichte Baureihe; ³⁾ L = Leichte Baureihe;

⁴⁾ S = Schwere Baureihe

$\frac{PN(\text{bar})}{10} = PN(\text{MPa})$

Lieferung ohne Mutter und Schneidring. Hinweise zum Bestellen von Komplettverschraubungen siehe Seite 17.

*Ergänzen Sie bitte die Bestellzeichen mit den Kennbuchstaben für das gewünschte Material.

Bestellzeichen-Ergänzungen		
Material	Kennbuchstaben Oberfläche und Material	Beispiel
Stahl, verzinkt, Cr(VI)-frei	CFX	T16SCFX
Edelstahl	71X	T16S71X
Messing	MSX	T16SMSX