

ETA-Danmark A/S
Kollegievej 6
DK-2920 Charlottenlund
Tel. +45 72 24 59 00
Fax +45 72 24 59 04
Internet www.eta danmark.dk



Authorised and notified according to Article 10 of the Council Directive 89/106/EEC of 21 December 1988 on the approximation of laws, regulations and administrative provisions of Member States relating to construction products

MEMBER OF EOTA

European Technical Approval ETA-09/0104

Trade name:

Purlin Tie 170 right/left
Purlin Tie 210 right/left
Purlin Tie 250 right/left
Purlin Tie 290 right/left

Holder of approval:

Gutzeit Verbindungssysteme GmbH & Co.
Rudolf-Diesel-Strasse 1
D-58730 Fröndenber, Industriegebiet
Tel. +49 2373 - 979261
Fax +49 2373 - 979266
Internet www.gutzeit-holzverbinder.de

Generic type and use of construction product:

Three-dimensional nailing plate (Purlin tie for timber-to-timber connections)

Valid from:
to:

2009-05-29
2014-05-29

Manufacturing plant:

Gutzeit Verbindungssysteme GmbH & Co.
Rudolf-Diesel-Strasse 1
D-58730 Fröndeberg, Industriegebiet

This European Technical Approval contains:

15 pages including 2 annexes which form an integral part of the document



European Organisation for Technical Approvals

Europæisk Organisation for Tekniske Godkendelser

I LEGAL BASIS AND GENERAL CONDITIONS

1 This European Technical Approval is issued by ETA-Danmark A/S in accordance with:

- Council Directive 89/106/EEC of 21 December 1988 on the approximation of laws, regulations and administrative provisions of Member States relating to construction products¹⁾, as amended by Council Directive 93/68/EEC of 22 July 1993²⁾.
- Bekendtgørelse 559 af 27-06-1994 (afløser bekendtgørelse 480 af 25-06-1991) om ikrafttræden af EF direktiv af 21. december 1988 om indbyrdes tilnærmelse af medlemsstaternes love og administrative bestemmelser om byggevarer.
- Common Procedural Rules for Requesting, Preparing and the Granting of European Technical Approvals set out in the Annex to Commission Decision 94/23/EC³⁾.
- EOTA Guideline ETAG 015 *Three-dimensional nailing plates*, September 2002 edition.

2 ETA-Danmark A/S is authorized to check whether the provisions of this European Technical Approval are met. Checking may take place in the manufacturing plant. Nevertheless, the responsibility for the conformity of the products to the European Technical Approval and for their fitness for the intended use remains with the holder of the European Technical Approval.

3 This European Technical Approval is not to be transferred to manufacturers or agents of manufacturers other than those indicated on page 1, or manufacturing plants other than those indicated on page 1 of this European Technical Approval.

4 This European Technical Approval may be withdrawn by ETA-Danmark A/S pursuant to Article 5(1) of Council Directive 89/106/EEC.

- 1) Official Journal of the European Communities N° L40, 11 Feb 1989, p 12.
- 2) Official Journal of the European Communities N° L220, 30 Aug 1993, p 1.
- 3) Official Journal of the European Communities N° L 17, 20 Jan 1994, p 34.

5 Reproduction of this European Technical Approval including transmission by electronic means shall be in full. However, partial reproduction can be made with the written consent of ETA-Danmark A/S. In this case partial reproduction has to be designated as such. Texts and drawings of advertising brochures shall not contradict or misuse the European Technical Approval.

6 This European Technical Approval is issued by ETA-Danmark A/S in English. This version corresponds fully to the version circulated within EOTA. Translations into other languages have to be designated as such.

I SPECIAL CONDITIONS OF THE EUROPEAN TECHNICAL APPROVAL

1 Definition of product and intended use

Definition of the product

Gutzeit purlin ties right/left 170, 210, 250 and 290 are one-piece non-welded, face-fixed purlin ties to be used in timber to timber connections. They are connected to the timber elements by ringed shank nails.

The purlin ties are made from pre-galvanized steel DX 51 D / Z 275 according to EN 10327:2004 with $R_e \geq 295 \text{ N/mm}^2$, $R_m \leq 360 \text{ N/mm}^2$ and $A_{80} \geq 22\%$. Dimensions, hole positions and typical installations are shown in Annex A. Purlin ties are made from steel with tolerances according to EN 10143.

Intended use

The purlin ties are intended for use in making connections in load bearing timber structures, as a connection between a beam and a purlin, where requirements for mechanical resistance and stability and safety in use in the sense of the Essential Requirements 1 and 4 of Council Directive 89/106/EEC shall be fulfilled.

The connection always contains two purlin ties (see Annex A).

The static and kinematic behaviour of the timber members or the supports shall be as described in Annex B.

The wood members may be of solid timber, glued laminated timber and similar glued members, or wood-based structural members with a characteristic density from 290 kg/m^3 to 420 kg/m^3 . This requirement to the material of the wood members may be fulfilled by using the following materials:

- Structural solid timber classified to C14-C40 according to EN 338 / EN 14081,
- Glulam classified to GL24-GL36 according to EN 1194 / EN 14080,
- LVL according to EN 14374,
- Parallam PSL,
- Intrallam LSL,
- Duo- and Triobalken,
- Layered wood plates,
- Plywood according to EN 636

Annex B states the load-carrying capacities of the purlin tie connections for a characteristic density of 350 kg/m^3 . For timber or wood based material with a lower characteristic density than 350 kg/m^3 the load-carrying capacities of the nailed connection shall be modified by the k_{dens} factor:

$$k_{\text{dens}} = \sqrt{\frac{\rho_k}{350}}$$

where ρ_k is the characteristic density of the timber in kg/m^3 .

The design of the connections shall be in accordance with Eurocode 5 or a similar national Timber Code. The wood members shall have a thickness which is larger than the penetration depth of the nails into the members.

The purlin ties are primarily for use in timber structures subject to the dry, internal conditions defined by service class 1 and 2 of Eurocode 5 and for connections subject to static or quasi-static loading.

The purlin ties can also be used in outdoor timber structures, service class 3, when a corrosion protection in accordance with Euro Code 5 is applied, or when stainless steel with similar or better characteristic yield and ultimate strength is employed.

Assumed working life

The assumed intended working life of purlin ties for the intended use is 50 years, provided that they are subject to appropriate use and maintenance.

The information on the working life should not be regarded as a guarantee provided by the manufacturer or ETA Danmark. An "assumed intended working life" means that it is expected that, when this working life has elapsed, the real working life may be, in normal use conditions, considerably longer without major degradation affecting the essential requirements.

2 Characteristics of product and assessment

ETAG paragraph	Characteristic	Assessment of characteristic
2.1 Mechanical resistance and stability*)		
6.1.1	Characteristic load-carrying capacity	See Annex B
6.1.2	Stiffness	No performance determined
6.1.3	Ductility in cyclic testing	No performance determined
2.2 Safety in case of fire		
6.2.1	Reaction to fire	The purlin ties are made from steel classified as Euroclass A1 in accordance with EN 1350-1 and EC decision 96/603/EC, amended by EC Decision 2000/605/EC
2.3 Hygiene, health and the environment		
6.3.1	Influence on air quality	No dangerous materials **)
2.4 Safety in use		
2.5 Protection against noise		
2.6 Energy economy and heat retention		
2.7 Related aspects of serviceability		
6.7.1	Durability	The purlin ties have been assessed as having satisfactory durability and serviceability when used in timber structures using the timber species described in Eurocode 5 and subject to the conditions defined by service class 1 and 2
6.7.2	Serviceability	
6.7.3	Identification	

*) See page 5 of this ETA

**) In accordance with <http://europa.eu.int/-/comm/enterprise/construction/internal/dangsub/dangmain.htm> In addition to the specific clauses relating to dangerous substances contained in this European Technical Approval, there may be other requirements applicable to the products falling within its scope (e.g. transposed European legislation and national laws, regulations and administrative provisions). In order to meet the provisions of the EU Construction Products Directive, these requirements need also to be complied with, when and where they apply.

Safety principles and partial factors

2.1 Mechanical resistance and stability

The characteristic load-carrying capacities are based on the characteristic values of the nail connections, the timber components and the steel plates. To obtain design values the capacities have to be divided by different partial factors for the material properties, the nail connection and the timber components in addition multiplied with the coefficient k_{mod} .

According to EN 1990 (Eurocode – Basis of design) paragraph 6.3.5 the design value of load-carrying capacity can be determined by reducing the characteristic values of the load-carrying capacity with different partial factors.

Thus, the characteristic values of the load-carrying capacity are determined also for timber failure $F_{Rk,N}$ (reaching the embedment strength of nails subjected to shear), $F_{90,Rk}$ (reaching the transverse tensile strength of the timber components) as well as for steel plate failure $F_{Rk,S}$. The design value of the load-carrying capacity is the smaller value of both load-carrying capacities.

$$F_{Rd} = \min \left\{ \frac{k_{mod} \cdot F_{Rk,N}}{\gamma_{M,H}}; \frac{F_{Rk,S}}{\gamma_{M,S}}; \frac{k_{mod} \cdot F_{90,Rk}}{\gamma_{M,H}} \right\}$$

Therefore, for timber failure and the nails connection the load duration class and the service class are included. The different partial factors γ_M for steel or timber, respectively, are also correctly taken into account.

See annex B for the characteristic load-carrying capacity in the direction F_1 .

The characteristic capacities of the purlin ties are determined by calculation assisted by testing as described in the EOTA Guideline 015 clause 5.1.2. They should be used for designs in accordance with Eurocode 5 or a similar national Timber Code.

Threaded nails (ringed shank nails) in accordance to EN 14592

In the formulas in Annex B the capacities for threaded nails calculated from the formulas of Eurocode 5 are used assuming a thick steel plate when calculating the lateral nail load-carrying-capacity.

The load bearing capacities of the brackets has been determined based on the use of connector nails 4,0 x 40 mm in accordance with the German national approval for the nails.

The characteristic withdrawal capacity of the nails has to be determined by calculation in accordance with EN 1995-1-

1: 2004, paragraph 8.3.2 (head pull-through is not relevant):

$$F_{ax,Rk} = f_{ax,k} \times d \times t_{pen}$$

Where:

$f_{ax,k}$	Characteristic value of the withdrawal parameter in N/mm^2
d	Nail diameter in mm
t_{pen}	Penetration depth of the profiles shank including the nail point in mm, $t_{pen} \geq 31$ mm

Based on tests by Versuchsanstalt für Stahl, Holz und Steine, University of Karlsruhe, the characteristic value of the withdrawal resistance for the threaded nails used can be calculated as:

$$f_{ax,k} = 50 \times 10^{-6} \times \sigma_k^2$$

Where:

σ_k	Characteristic density of the timber in kg/m^3
------------	--

The shape of the nail directly under the head shall be in the form of a truncated cone with a diameter under the nail head which exceeds the hole diameter.

No performance has been determined in relation to ductility of a joint under cyclic testing. The contribution to the performance of structures in seismic zones, therefore, has not been assessed.

No performance has been determined in relation to the joint's stiffness properties - to be used for the analysis of the serviceability limit state.

2.7 Related aspects of serviceability

2.7.1 Corrosion protection in service class 1 and 2.

In accordance with ETAG 015 the purlin ties are made from pre-galvanized steel DX 51 D / Z 275 according to EN 10327:2004 with $R_e \geq 295 N/mm^2$, $R_m \leq 360 N/mm^2$ and $A_{80} \geq 22\%$.

3 Attestation of Conformity and CE marking

3.1 Attestation of Conformity system

The system of attestation of conformity is 2+ described in Council Directive 89/106/EEC (Construction Products Directive) Annex III.

- a) Tasks for the manufacturer:
 - (1) Factory production control,
 - (2) Initial type testing of the product,
- b) Tasks for the notified body:
 - (1) Initial inspection of the factory and the factory production control,
 - (2) Continuous surveillance

3.2 Responsibilities

3.2.1 Tasks of the manufacturer

3.2.1.1 Factory production control

The manufacturer has a factory production control system in the plant and exercises permanent internal control of production. All the elements, requirements and provisions adopted by the manufacturer are documented in a systematic manner in the form of written policies and procedures. This production control system ensures that the product is in conformity with the European Technical Approval.

The manufacturer shall only use raw materials supplied with the relevant inspection documents as laid down in the control plan⁴. The incoming raw materials shall be subject to controls and tests by the manufacturer before acceptance. Check of materials, such as sheet metal, shall include control of the inspection documents presented by suppliers (comparison with nominal values) by verifying dimension and determining material properties, e.g. chemical composition, mechanical properties and zinc coating thickness.

The manufactured components are checked visually and for dimensions.

The control plan, which is part of the technical documentation of this European Technical Approval,

⁴ The control plan has been deposited at ETA-Danmark and is only made available to the approved bodies involved in the conformity attestation procedure.

includes details of the extent, nature and frequency of testing and controls to be performed within the factory production control and has been agreed between the approval holder and ETA Danmark.

The results of factory production control are recorded and evaluated. The records include at least the following information:

- Designation of the product, basic material and components;
- Type of control or testing;
- Date of manufacture of the product and date of testing of the product or basic material and components;
- Result of control and testing and, if appropriate, comparison with requirements;
- Signature of person responsible for factory production control.

The records shall be presented to ETA Danmark on request.

3.2.1.1 Initial type testing of the product

For initial type-testing the results of the tests performed as part of the assessment for the European Technical Approval shall be used unless there are changes in the production line or plant. In such cases the necessary initial type testing has to be agreed between ETA Danmark and the notified body.

3.2.2. Tasks of notified bodies

3.2.2.1 Initial inspection of the factory and the factory production control

The approved body should ascertain that, in accordance with the control plan, the factory, in particular the staff and equipment, and the factory production control, are suitable to ensure a continuous and orderly manufacturing of the angle brackets with the specifications given in part 2.

3.2.2.2 Continuous surveillance

The approved body shall visit the factory at least twice a year for routine inspections. It shall be verified that the system of factory production control and the specified manufacturing processes are maintained, taking account of the control plan.

The results of product certification and continuous surveillance shall be made available on demand by the certification body to ETA Danmark. Where the provisions of the European Technical Approval and the control plan are no longer fulfilled, the certificate

of conformity shall be withdrawn by the approved body.

3.3 CE marking

The CE marking shall be affixed on each packaging of angle brackets. The initials "CE" shall be followed by the identification number of the notified body and shall be accompanied by the following information:

- Name or identifying mark of the manufacturer
- The last two digits of the year in which the marking was affixed
- Number of the European Technical Approval
- Name and size of product
- Number of the ETA Guideline (ETAG no. 015)
- Number of the EC Certificate of Conformity

4 Assumptions under which the fitness of the product for the intended use was favourably assessed

4.1 Manufacturing

Gutzeit Purlin Ties are manufactured in accordance with the provisions of this European Technical Approval using the manufacturing processes as identified in the inspection of the plant by the notified inspection body and laid down in the technical documentation.

4.2 Installation

The execution of the connection shall be in accordance with the following:

A purlin tie connection is deemed fit for its intended use provided:

- The structural members to which the purlin ties are fixed shall be:
 - Restrained against rotation.
 - Strength class C14 or better, see section 1 of this ETA
 - Free from wane under the purlin tie.
- The tensile perpendicular to the grain capacity of the timber member to be used in conjunction with the purlin tie is to be checked by the designer of the structure to ensure it is not less than the purlin tie capacity and, if necessary, the purlin tie capacity reduced accordingly.
- The gap between the timber members does not exceed 3 mm.
- There are no specific requirements relating to preparation of the timber members.

4.3 Maintenance and repair

Maintenance is not required during the assumed intended working life. Should repair prove necessary, it is normal to replace the purlin tie.



Thomas Bruun
Manager, ETA-Danmark

Annex A
Product details and definitions

Table A.1 Materials specification

Purlin Ties Type	Thickness (mm)	Steel specification	Coating specification
right/left (170-290)	2,0	DX 51 D ¹⁾	Z275
¹⁾ $R_e \geq 295 \text{ N/mm}^2$, $R_m \leq 360 \text{ N/mm}^2$ and $A_{80} \geq 22\%$			

Table A.2 Dimensions

Purlin Ties Type	Length (mm)		Width (mm)	
	min	max	min	max
right/left	169	172	33,5	35,0
right/left	209	212	33,5	35,0
right/left	249	252	33,5	35,0
right/left	289	292	33,5	35,0

Table A.3 Fastener specification

Nail type	Nail size (mm)		Finish
	Diameter	Length	
According to prEN 14592			
Threaded nail	4,0	40	Electroplated zinc
<p>In the load-carrying-capacities of the nailed connection the capacities for threaded nails calculated from the formulas of Eurocode 5 are used assuming a thick steel plate when calculating the lateral nail load-carrying-capacity.</p> <p>The load-carrying-capacities of the purlin ties have been determined based on the use of connector nails 4,0 x 40 mm in accordance with the German national specification for the nails.</p> <p>The characteristic withdrawal capacity of the nails has to be determined by calculation in accordance with EN 1995-1-1:2004, paragraph 8.3.2 (head pull-through is not relevant):</p> $F_{ax,Rk} = f_{ax,k} \times d \times t_{pen}$ <p>Where:</p> <p>$f_{ax,k}$ Characteristic value of the withdrawal parameter in N/mm^2</p> <p>d Nail diameter in mm</p> <p>t_{pen} Penetration depth of the profiled shank including the nail point in mm, $t_{pen} \geq 31 \text{ mm}$</p> <p>Based on tests by Versuchsanstalt für Stahl, Holz und Steine, University of Karlsruhe, the characteristic value of the withdrawal resistance for the threaded nails used can be calculated as:</p> $f_{ax,k} = 50 \times 10^{-6} \times \rho_k^2$ <p>Where:</p> <p>ρ_k Characteristic density of the timber in kg/m^3</p> <p>The shape of the nail directly under the head shall be in the form of a truncated cone with a diameter under the nail head which exceeds the hole diameter.</p>			

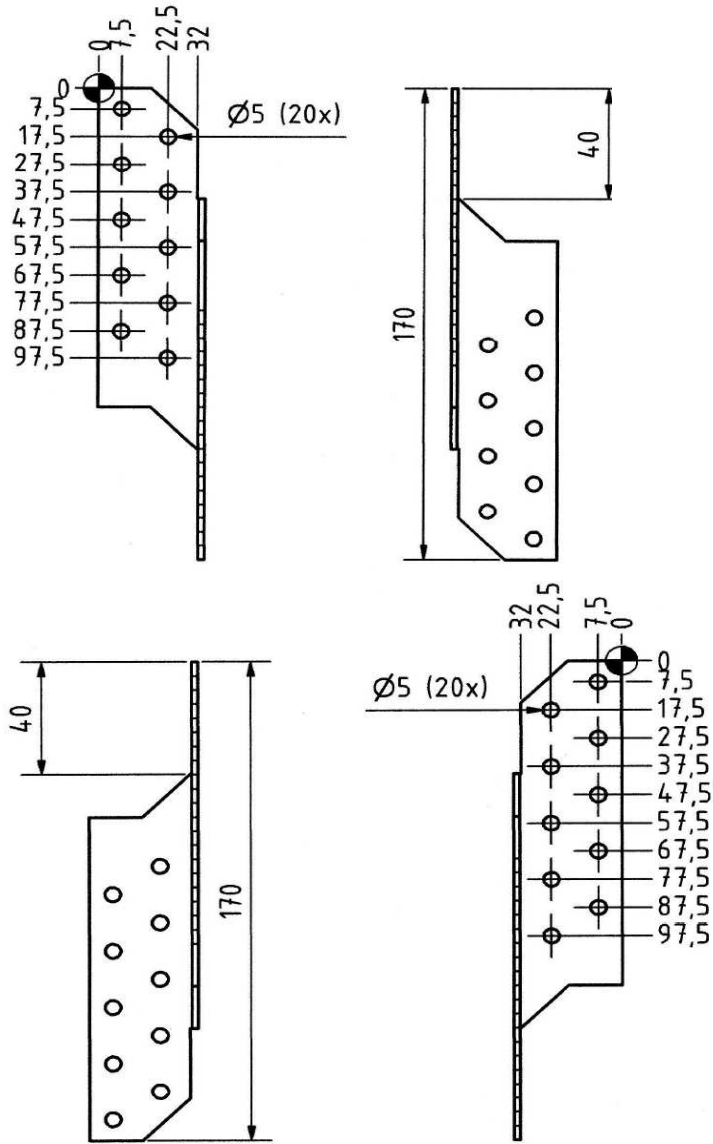

Figure A.1 Dimensions of Purlin Ties 170 right/left

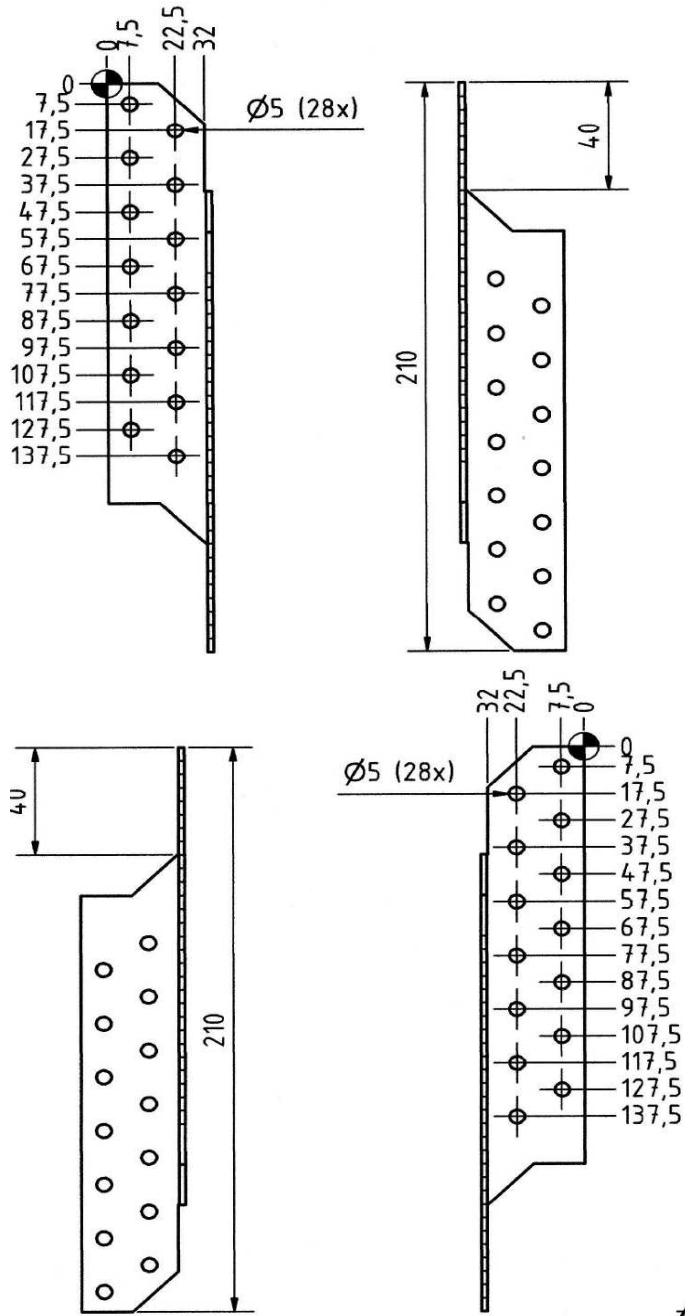

Figure A.2 Dimensions of Purlin Ties 210 right/left

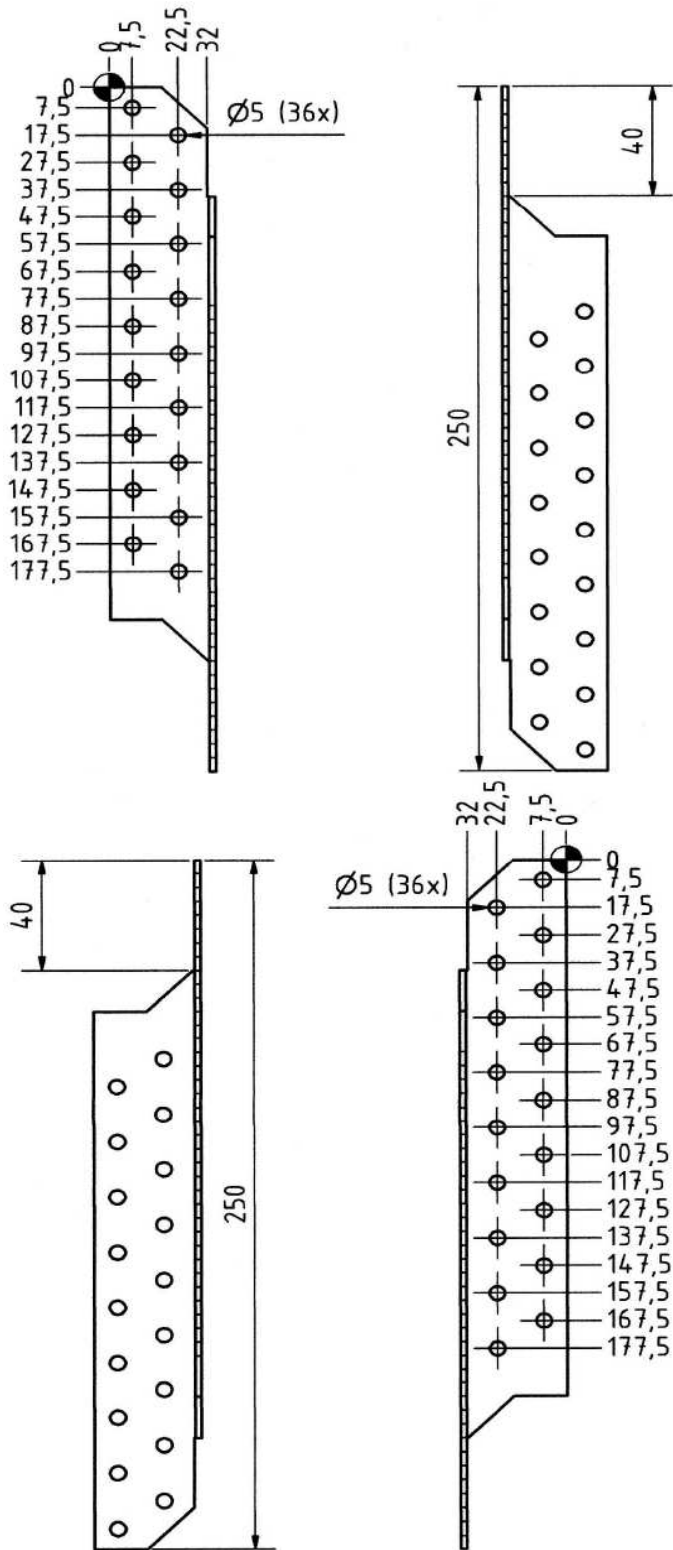

Figure A.3 Dimensions of Purlin Ties 250 right/left

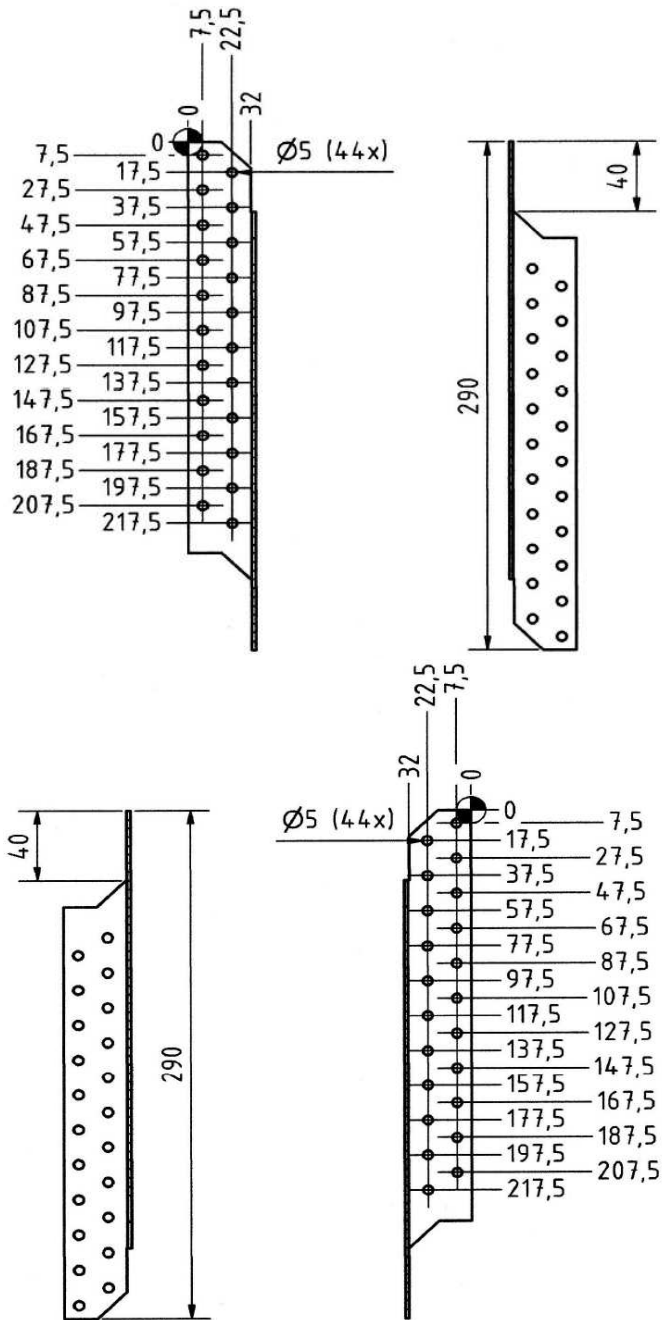

Figure A.4 Dimensions of Purlin Ties 290 right/left

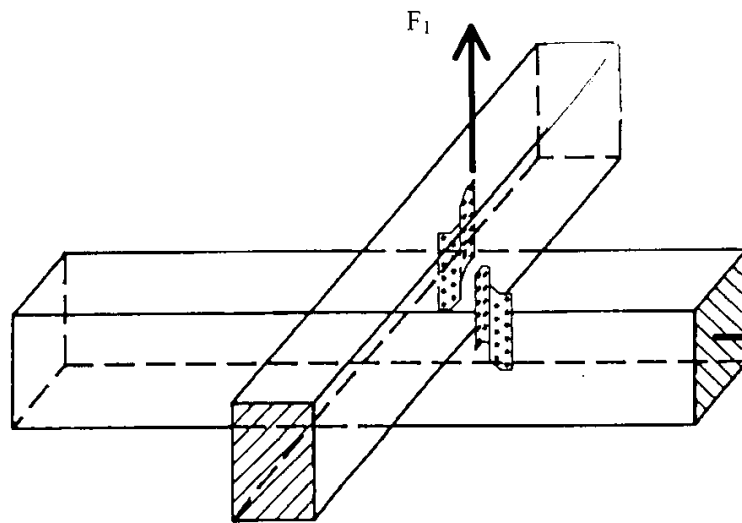

Figure A.5 Typical installation

Annex B

Characteristic load-carrying capacities

Support conditions

The distance between the timber elements in the area of the connection must not exceed 3 mm. The timber members are prevented from rotation.

Fastener specification

The holes are to be nailed beginning at the end of the purlin tie.

Wane

Wane is not allowed, the timber has to be sharp-edged in the area of the purlin ties.

Characteristic load-carrying capacities 2 purlin ties

Table B.1: Characteristic load-carrying capacities Load F_1 – 2 Purlin Ties / connection

Purlin Ties	Number of nails	Nail failure FRk,N [kN]	Steel failure FRk,S [kN]	Transverse tensile failure
right/left 170, 210, 250, 290	2 x 2	2,2	11,9	Design according to equation (B.1)
	2 x 3	3,4	11,9	
	2 x 4	5,5	11,9	
	2 x 5	8,5	11,9	
	2 x 6	9,9	11,9	
	2 x 7	13,9	11,9	
	2 x 8	15,3	11,9	
	2 x 9	19,7	11,9	
	2 x 10	21,4	11,9	
	2 x 11	26,0	11,9	
	2 x 12	27,9	11,9	

Splitting

For a lifting force F_1 splitting has to be proved, when necessary, for both timber elements. The capacity of a connection with two purlin ties on both sides of the timber element is calculated according to the general splitting design for connections with mechanical fasteners in EN 1995:2004.

$$F_{90,Rk} = 14 \cdot b \cdot \sqrt{\frac{h_e}{\left(1 - \frac{h_e}{h}\right)}} \quad (B.1)$$

Where:

- $F_{90,Rk}$ the characteristic splitting capacity in N
- b the member thickness, in mm
- h_e is the loaded edge distance to the centre of the most distant fastener in mm
- h the timber member height in mm

The design value of the force component perpendicular to the structural member's axis has to be lower than the design capacity $F_{90,Rd}$.