

Order Number
213309-7700

molex

Application Tooling Specification

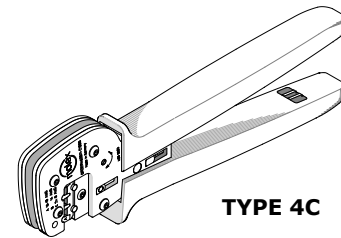

TYPE 4C

FEATURES

- A full cycle ratcheting hand tool ensures complete crimps.
- Ergonomically designed soft handles.
- Precisely designed crimping profiles with simple contact positioning.
- Easy handling due to outstanding force ratio.
- Tooling can be installed in the 63816-1915 Power Crimp Adapter, which is installed into the 63816-0270 (110 V) or 63816-0280 (220 V) Battery Powered Tools and the 63816-1900 Electric Crimp Machine.
- This tool is IPC/WHMA-A-620 and RoHS compliant.

SCOPE

Products: High Temperature VersaBlade Male and Female Crimp Terminals, 14-18 AWG UL3321 wires

Terminal Series No.	Terminal Order No. (2)	Wire Size and Type		Insulation Diameter IPC/WHMA-A-620 (1)		Strip Length	
		AWG	Type	mm	In.	mm	In.
217347	217347-8000	14	UL3321	3.40-3.70	.134-.146	4.0-4.8	.16-.19
		16		2.80-3.30	.110-.130		
		18		2.60-2.90	.102-.114		
217348	217348-8000	14	UL3321	3.40-3.70	.134-.146	4.0-4.8	.16-.19
		16		2.80-3.30	.110-.130		
		18		2.60-2.90	.102-.114		

(1) To achieve IPC/WHMA-A-620 insulation crimps, use this insulation OD range.
(2) Reeled terminals; user must cut terminals from reel; 0.50mm (.020") max cutoff tab.

Insulation Crimp Note

Due to the terminal's insulation grip design or insulation diameter range, this tool uses overlap form geometry in the insulation punch. This produces an overlap insulation crimp (A-620-compliant). Although the insulation punch profile may appear lopsided, this is a normal condition for this tool. See figure to the right.

Insulation crimps from the 14 AWG, 16 AWG, and 18 AWG crimp profiles will have an overlap appearance.

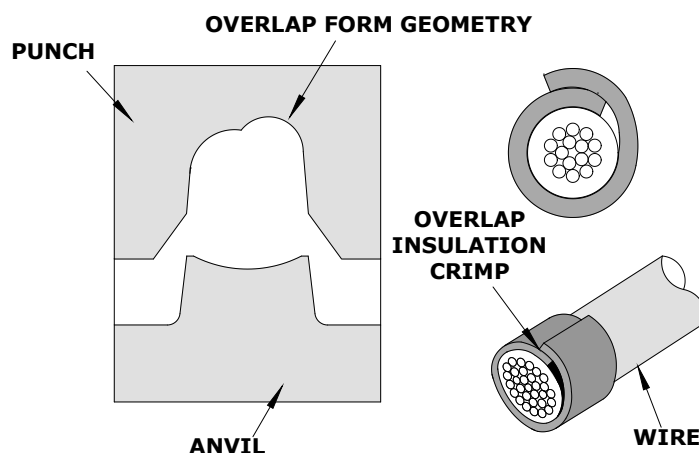

DEFINITION OF TERMS

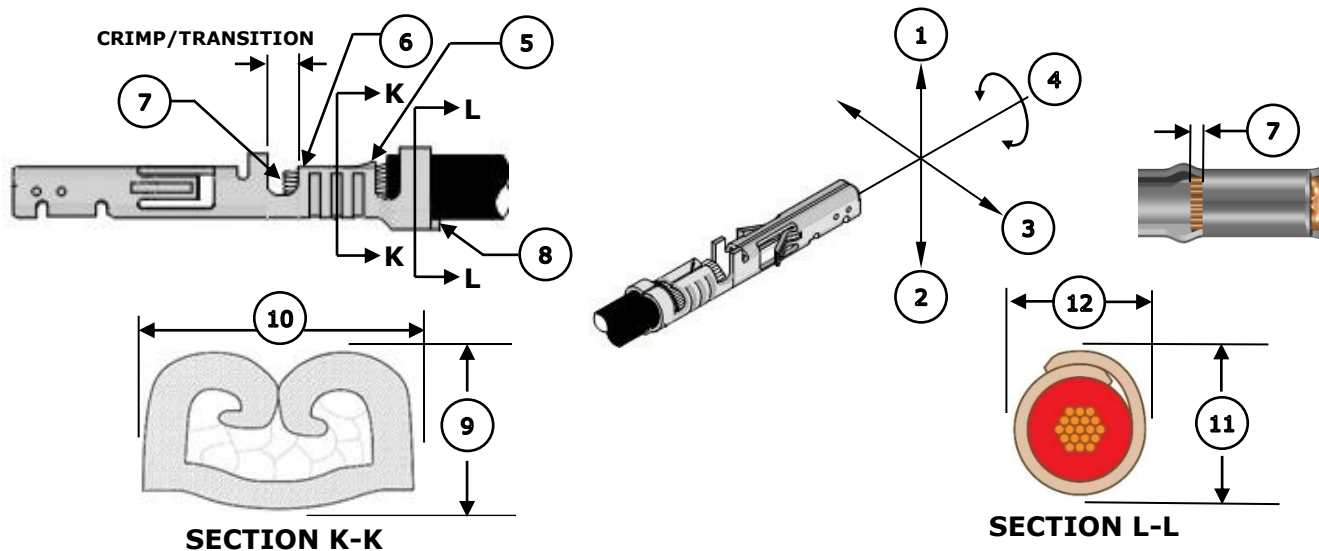

Note: Images above are a generic terminal representation. The actual terminals of the scope may look different.

CRIMP SPECIFICATION

Feature	Requirement						
1. Bend Up	3° Max						
2. Bend Down	3° Max						
3. Twist	3° Max						
4. Roll	5° Max						
5. Bell Mouth Rear	0.30-0.80mm (.012-.031")						
6. Bell Mouth Front	Not Applicable						
7. Conductor Brush	0.30-1.20mm (.012-.047")						
8. Cut-Off Tab	0.50mm (.020") Max						
Conductor Crimp	Terminal Order No.	Crimp Profile	Wire Size	9. Crimp Height		10. Crimp Width (Ref)	
	217347-8000 217348-8000	B	14 AWG	1.45-1.55mm	.057-.061"	2.40-2.60mm	.094-.102"
		C	16 AWG	1.25-1.35mm	.049-.053"	2.40-2.60mm	.094-.102"
		A	18 AWG	1.05-1.15mm	.041-.045"	2.40-2.60mm	.094-.102"
Insulation Crimp	Terminal Order No.	Wire Size		11. Crimp Height (Ref)		12. Crimp Width (Ref)	
	217347-8000 217348-8000	14 AWG		3.40-3.60mm	.134-.142"	3.90-4.10mm	.153-.161"
		16 AWG		3.40-3.60mm	.134-.142"	3.50-3.60mm	.138-.142"
		18 AWG		3.20-3.40mm	.126-.134"	3.10-3.20mm	.122-.126"
Pull Force	Terminal Order No.	Wire Size		Minimum Pull Force		To be measured with no influence from the insulation crimp.	
	217347-8000 217348-8000	14 AWG		147.1N	33 lbs.		
		16 AWG		127.5N	29 lbs.		
		18 AWG		98.1N	22 lbs.		

Tool Qualification Notes

1. Pull force should be measured with no influence from the insulation crimp.
2. The above specifications are guidelines to an optimum crimp.

Note

Crimp specifications are provided with this document as reference only. Due to the wide range of wires, stranding, insulation diameters and durometers, actual crimp height measurements may vary slightly. An occasional destructive pull force test should be performed to check hand tool crimp. Pull force value must exceed the minimum pull force specifications listed.

CAUTION: Crimp only Molex terminals listed above with this tool. Do not crimp hardened objects as damage can occur to the tool or die.

OPERATION

Open the tool by squeezing the handles together. At the end of the closing stroke, the ratchet mechanism will release the handles, and the hand tool will spring open.

Crimping the Terminal

Make sure the terminal locator is against the hand crimp tool and the lock is up. For crimping, terminals must be loaded while the locator is closed and locked. The terminal locator may need to be pushed down slightly for terminals to load easily. See Figure 2.

1. To raise the wire stop, press the tab on the wire stop as shown in Figure 2. Insert the proper terminal into the nest opening and release the wire stop to lower it. Make sure the terminal is fully seated in the nest opening.
2. Insert the proper pre-stripped wire over the terminal. Gently touch the wire stop with the end of the wire. See Figures 3 and 4.

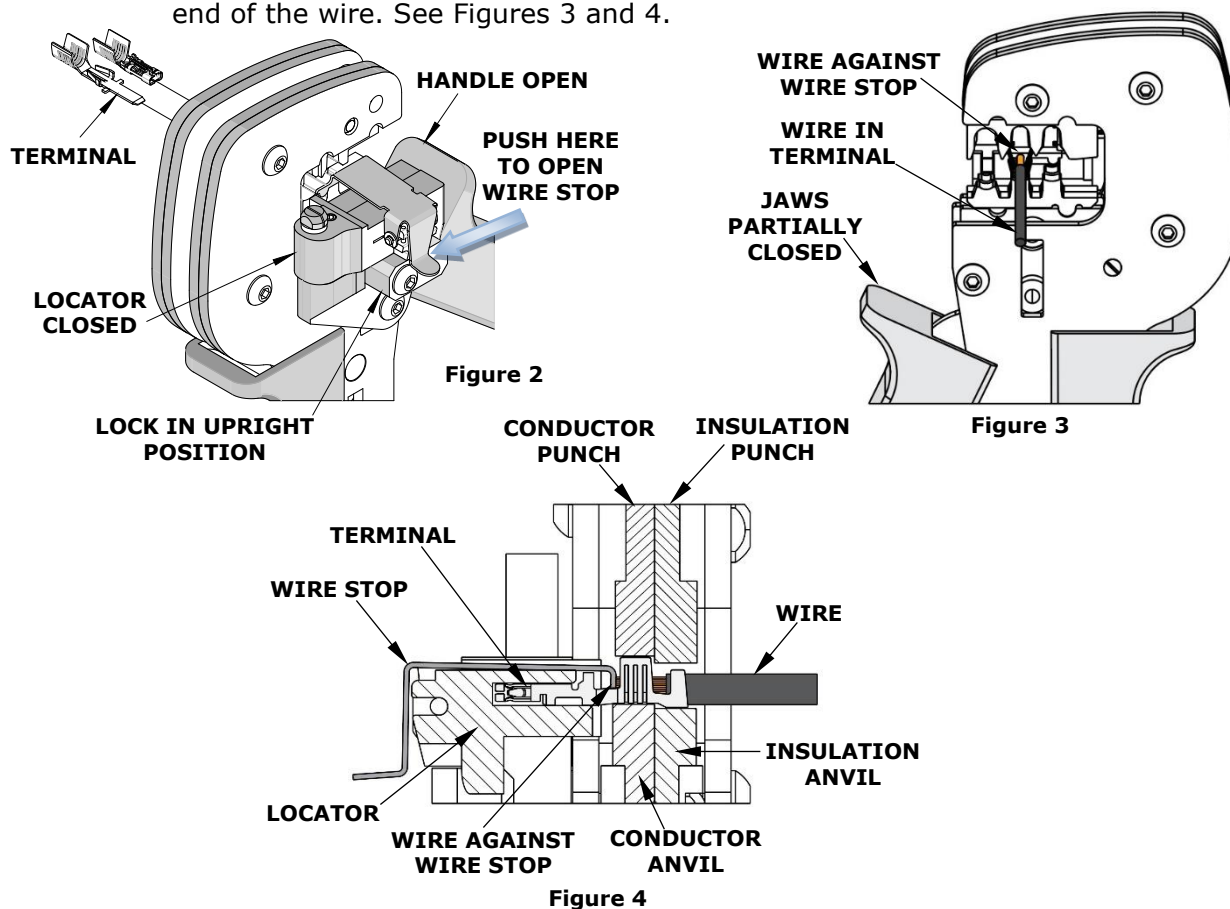

3. While keeping the wire against the wire stop, crimp the terminal by squeezing the tool handles until the ratchet mechanism releases. Release handles to open the jaws.

Note: The full-cycle ratchet action will not release the tool until it has been fully closed.

4. Remove the crimped terminal from the terminal locator by pressing the tab on the wire stop and gently pulling on the wire.
5. Visually inspect the crimped terminal for proper crimp location and crimp height.

MAINTENANCE

It is recommended that each operator of the tool be made aware of and responsible for the following maintenance steps:

1. Remove dust, moisture and other contaminants with a clean brush or a soft, lint-free cloth.
2. Do not use any abrasive materials that could damage the tool.
3. Make certain all pins, pivot points and bearing surfaces in the tool head are protected with a thin coat of high-quality machine oil. Do not oil excessively. This tool was engineered for durability, but like any fine piece of equipment, it needs cleaning and lubrication for a maximum service life of trouble-free crimping. The use of a light oil such as 30 weight automotive oil every 5,000 crimps or monthly will significantly enhance the tool life and ensure a stable calibration. See Figure 5 for lubrication points.
4. Store the tool in a clean and dry area when it is not in use.

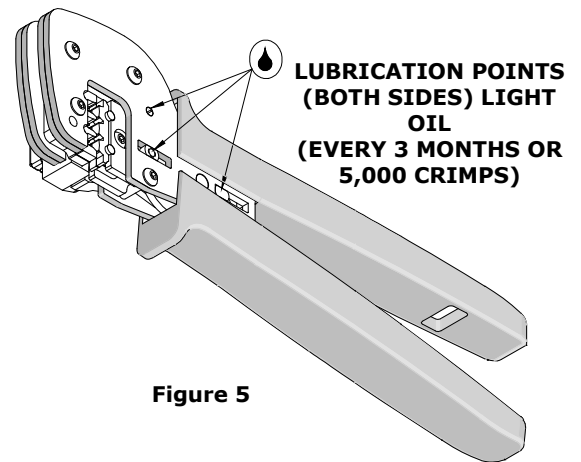

Figure 5

Miscrimps or Jams (Hand Crimp Tool Only)

Should this tool ever become stuck or jammed in a partially closed position, **do not force the handles open or closed**. The anti-backup ratchet will release by rotating the small, slotted screw marked with an arrow. See Figure 9.

Warranty

This hand tool is for electrical terminal crimping purposes only. This hand tool is made of the best quality materials. All vital components are long life tested. All tools are warranted to be free of manufacturing defects for a period of 30 days. Should such a defect occur, Molex will repair or exchange the tool free of charge. This repair or exchange will not be applicable to altered, misused or damaged tools.

CAUTION: Molex crimp specifications are valid only when used with Molex terminals and tooling.

CAUTIONS

1. Manually powered hand tools are intended for low-volume use or field repair. This tool is **NOT** intended for production use. Repetitive use of this tool should be avoided.
2. Insulated rubber handles are not protection against electrical shock.
3. Wear eye protection when operating or maintaining this tool.
4. Use only the Molex terminals specified for crimping with this tool.

CAUTION: Repetitive use of this tool should be avoided.

CERTIFICATION

Molex does not certify or re-certify commercial grade hand tools but rather supplies the following guidelines for customers to re-certify hand tools:

- This tool is qualified to pull force only. To re-certify, crimp a terminal to a wire that has been stripped 12.7mm (1/2") long so that there is no crimping of the insulation. Pull the terminal and wire at a rate no faster than 25mm (1.00") per minute. See the Molex website for the Quality Crimp Handbook for more information on pull testing.
- When the hand tool is no longer capable of achieving minimum pull force, it should be taken out of service and replaced.
- The tool frame is very difficult to disassemble and reassemble. Customer repair is not recommended.

The chart below shows all applications for this crimp tooling:

Tool Order No.	Tool Description	Adapter Order No.	Adapter Description	Figure No.
63810-1000	Hand Crimp Frame (Long)	—	—	6
63816-0270	Battery Power Tool (110 V)	63816-1915	Power Crimp Adapter	7
63816-0280	Battery Power Tool (220 V)	63816-1915	Power Crimp Adapter	7
63816-1900	Electric Crimp Machine	63816-1915	Power Crimp Adapter	8

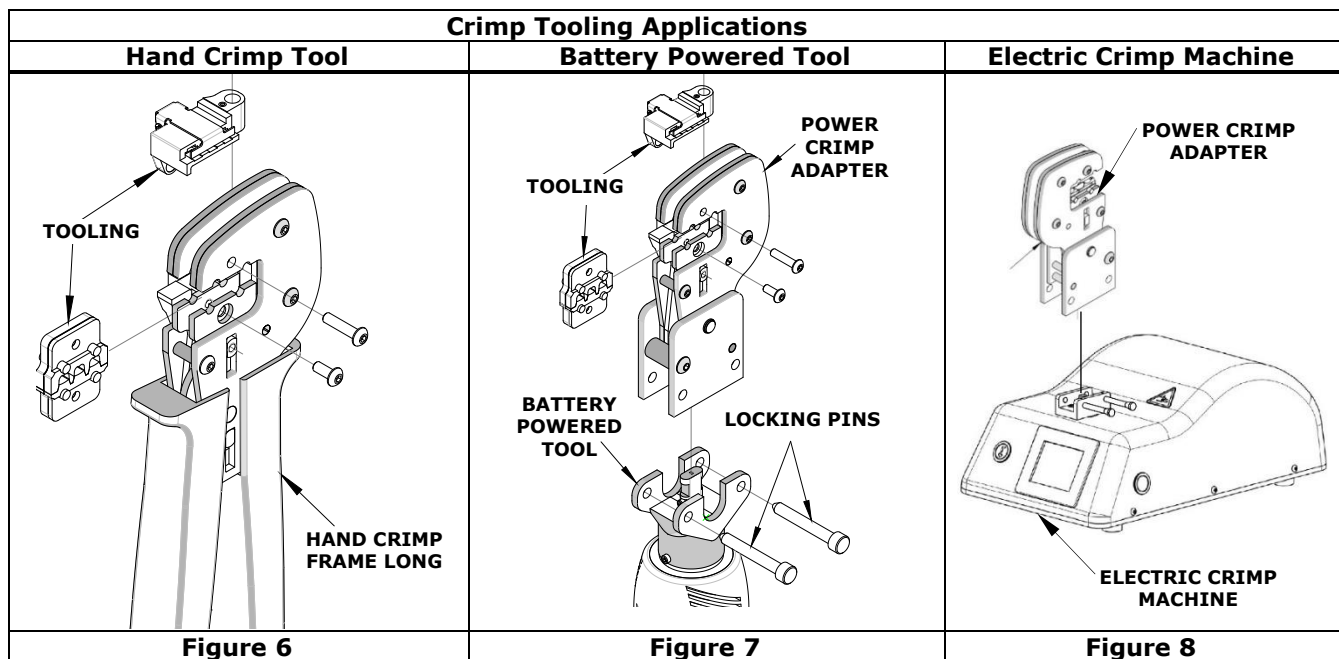

WARNING: NEVER operate, service or install tool kits or adjust the power crimp head without proper instruction and without first reading and understanding the instructions in the proper manual or specification sheet. See chart above for the correct manual or specification sheet.

WARNING: NEVER install tooling or service this tool while it is connected to any power source. Make sure the power is turned off.

CAUTION: Keep fingers away from the crimping area when operating this tool. It may cause severe injury.

CAUTION: Wear safety glasses when operating or servicing this tool.

HAND TOOL PARTS LIST

Item Number	Order Number	Description	Quantity
1	213309-7700	Hand Crimp Tool	1
2	213309-7775	Terminal Locator	1

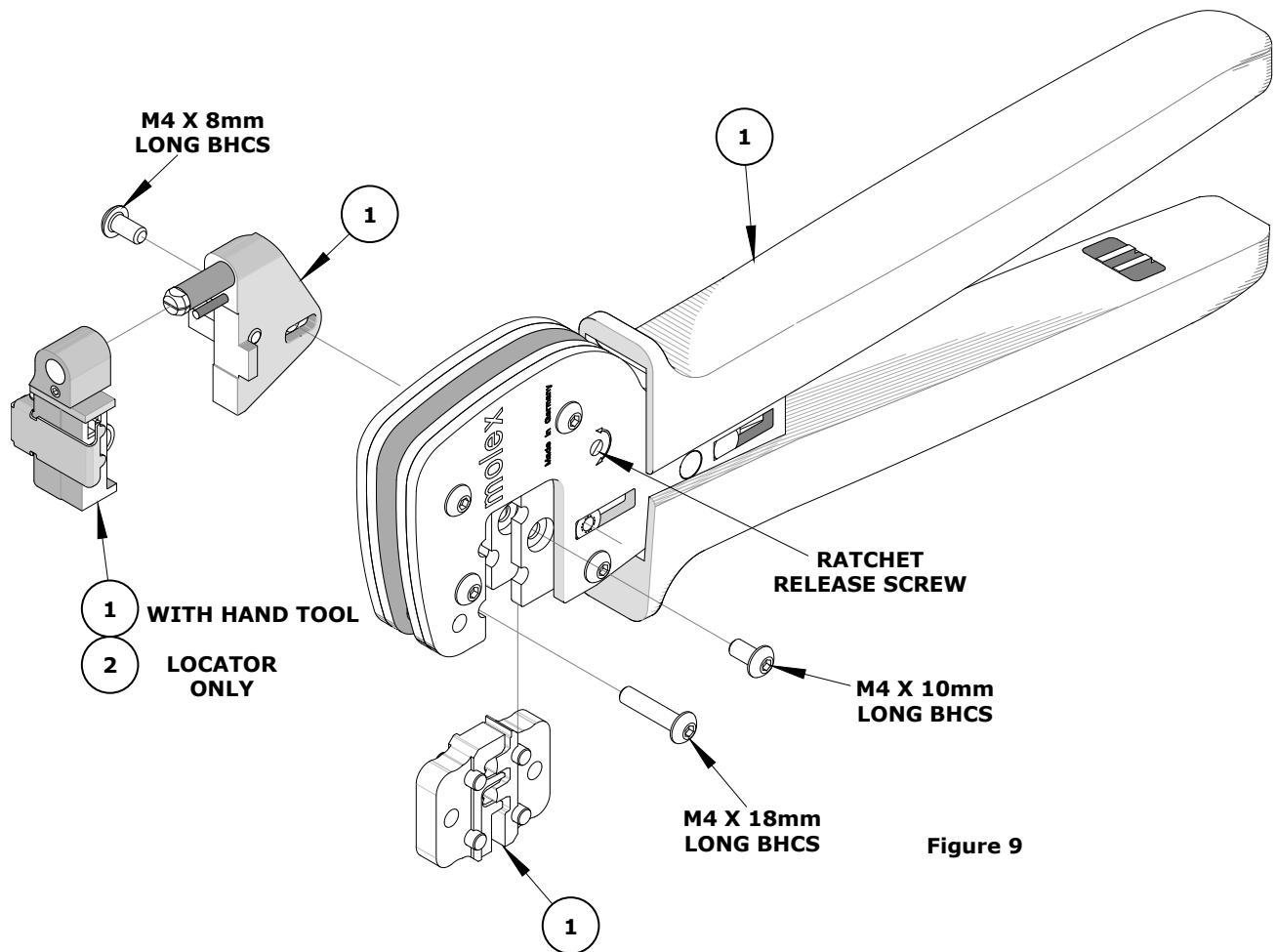

Figure 9

Application Tooling Support

Phone: (402) 458-TOOL (8665)
E-Mail: toolingsupport@molex.com
Website: www.molex.com/applicationtooling

Molex is a registered trademark of Molex, LLC in the United States of America and may be registered in other countries; all other trademarks listed herein belong to their respective owners.