

for size 52; ND 160 and 320
for size 62; ND 160

Welding nipple: Material St.52.3
Flange: Material St. 52.3

Pressure rating	up to 160 bar				up to 320 bar			
	WRD/WRZ/WRH 52 S 52, S _L 52, WEH 52, DB 52, MG 52, MK 52	S62, S _L 62, WEH 62, MG 62, MK 62	S82, S _L 82, WEH 82, DB 82, MG82, MK 82	S 102, S _L 102, WEH 102, MG 102, MK 102	WRD/WRZ/WRH 52 S52, S _L 52, WEH 52, DB 52, MG 52, MK 52	S62, S _L 62, WEH 62, MG 62, MK 62	S 82, S _L 82, WEH 82, DB 82, MG 82, MK 82	S 102, S _L 102, WEH 102, MG 102, MK 102
B1	100	120	150	180	100	120	150	180
ØD1	81	97	118	142	81	97	118	142
ØD2	45	54	73	89	40,3	51,1	69,6	79,3
ØD3	50	63	84	94	40,3	51,1	69,6	79,3
ØD4	53	66	87	98	43	54	73	83
ØD5	60,3	76,1	101,6	114,3	60,3	76,1	101,6	114,3
ØD6	17	21	25	33	17	21	25	33
D7	98	118	145	175	98	118	145	175
ØD8	76,1	101,6	114,3	139,7	76,1	101,6	114,3	139,7
ØD9	66	87	98	118	54	73	83	100
ØD10	63	84	94	115	51,1	69,6	79,3	95,5
ØD11	50	63	84	94	40,3	51,1	69,6	79,3
ØD12	53	66	87	98	43	54	73	83
ØD13	60,3	76,1	101,6	114,3	60,3	76,1	101,6	114,3
L1	90	110	130	160	90	110	130	160
L2	22	26	30	35	22	26	30	35
L3	35	45	55	65	35	45	55	65
L4	90	105	115	110	90	105	115	110
R1	-	-	5	5	-	5	5	5
R2	3	3	5	5	3	5	5	5

For ordering code see page 2

Pressure- rating	Flange for valve type	Seal- material	Conn. flange complete item 1 to 4	Weld neck item 1	Flange item 2	S.H.C.S.			O-ring item 4		Pipe reduction item 5
						item 3 Msp					
up to 160 bar	WRD/WRZ/WRH 52 S 52, S _L 52, WEH 52, DB 52, MG 52, MK 52	NBR	303901	134734	133778	M16 x 80	210 Nm	003140	50,16 x 5,33	009345	135000
		FPM	303941							009346	
	S 62, S _L 62, WEH 62, MG 62, MK 62	NBR	303903	134736	133478	M20 x 100	430 Nm	003160	59,7 x 5,33	009112	135001
		FPM	303943							009113	
	S 82, S _L 82, WEH 82, DB 82, MG 82, MK 82	NBR	303905	134738	133976	M24 x 120	730 Nm	003177	78,75 x 5,33	008035	135002
		FPM	303945							009114	
	S 102, S _L 102, WEH 102 MG 102, MK 102	NBR	303907	134741	133980	M30 x 140	1450 Nm	003182	94,6 x 5,33	009115	135003
		FPM	303947							009116	
up to 320 bar	WRD/WRZ/WRH 52 S 52, S _L 52, DB 52, WEH 52, MG 52, MK 52	NBR	303921	133779	133778	M16 x 80	210 Nm	003140	50,16 x 5,33	009345	135004
		FPM	303961							009346	
	S 62, S _L 62, WEH 62, MG 62, MK 62	NBR	303923	133784	133478	M20 x 100	430 Nm	003160	59,7 x 5,33	009112	135005
		FPM	303963							009113	
	S 82, S _L 82, WEH 82, DB 82, MG 82, MK 82	NBR	303925	133978	133976	M24 x 120	730 Nm	003177	78,75 x 5,33	008035	135006
		FPM	303965							009114	
	S 102, S _L 102, WEH 102, MG 102, MK 102	NBR	303927	133981	133980	M30 x 140	1450 Nm	003182	94,6 x 5,33	009115	135007
		FPM	303967							009116	

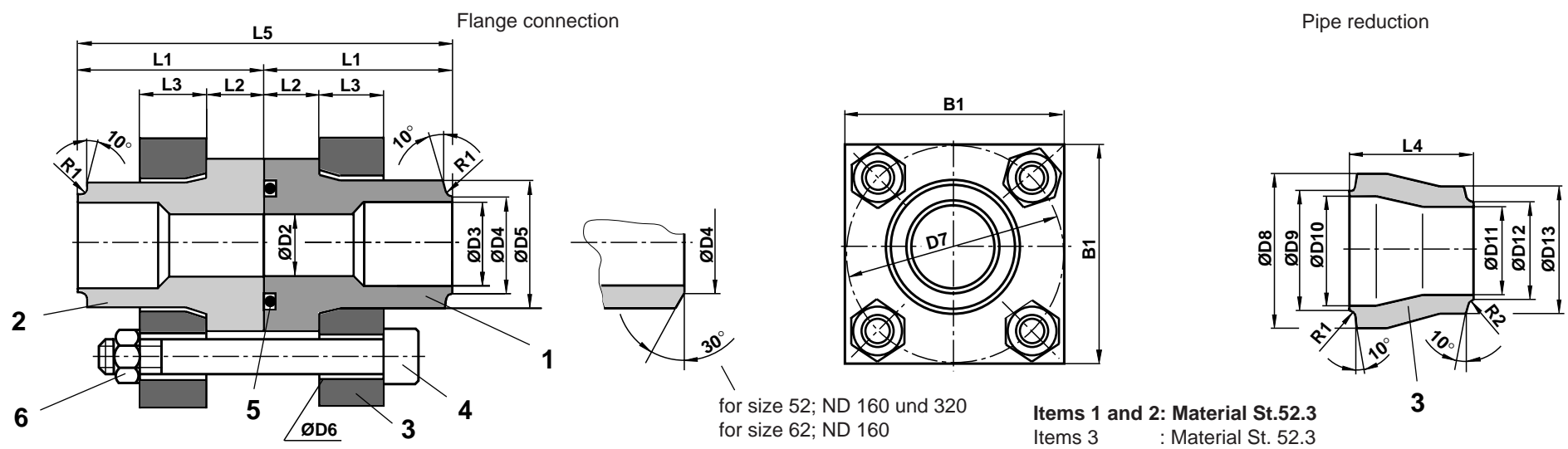

Pressure rating	up to 160 bar				up to 320 bar			
Flange for valve type	WRD/WRZ/WRH 52 S 52, S _L 52, WEH 52, DB 52, MG 52, MK 52	S62, S _L 62, WEH 62, MG 62, MK 62	S82, S _L 82, WEH 82, MG82, MK 82	S 102, S _L 102, WEH 102, MG 102, MK 102	WRD/WRZ/WRH 52 S52, S _L 52, WEH 52, DB 52, MG 52, MK 52	S62, S _L 62, WEH 62, MG 62, MK 62	S 82, S _L 82, WEH 82, DB 82, MG 82, MK 82	S 102, S _L 102, WEH 102, MG 102, MK 102
B1	100	120	150	180	100	120	150	180
ØD2	45	54	73	89	40,3	51,1	69,6	79,3
ØD3	50	63	84	94	40,3	51,1	79,3	79,3
ØD4	53	66	87	98	43	54	73	83
ØD5	60,3	76,1	101,6	114,3	60,3	76,1	101,6	114,3
ØD6	17	21	25	33	17	21	25	33
D7	98	118	145	175	98	118	145	175
ØD8	76,1	101,6	114,3	139,7	76,1	101,6	114,3	139,7
ØD9	66	87	98	118	54	73	83	100
ØD10	63	84	94	115	51,1	69,6	79,3	95,5
ØD11	50	63	84	94	40,3	51,1	69,6	79,3
ØD12	53	66	87	98	43	54	73	83
ØD13	60,3	76,1	101,6	114,3	60,3	76,1	101,6	114,3
L1	90	110	130	160	90	110	130	160
L2	22	26	30	35	22	26	30	35
L3	35	45	55	65	35	45	55	65
L4	90	105	115	110	90	105	115	110
L5	180	260	260	320	180	220	260	320
R1	-	-	5	5	-	5	5	5
R2	3	3	5	5	3	5	5	5

For ordering code see 4

Pressure-rating	Flange for valve type	Seal-material	Flange union compl.	Weld neck item 1	Weld neck item 2	Flange item 3	S.H.C.S.			O-ring item 5		Hexagon nut item 6		Pipe reduct. item 7	
							item 4	Msp							
up to 160 bar	WRD/WRZ/WRH 52 S 52, S _L ^V 52, WEH 52, DB 52, MG 52, Mk 52	NBR	303900	134734	134735	133778	M16 x 140	210 Nm	009108	50,16 x 5,33	009345	M16	003755	135000	
		FPM	303940								009346				
	S 62, S _L ^V 62, WEH 62, MG 62, MK 62	NBR	303902	134736	134737	133478	M20 x 180	430 Nm	003168	59,7 x 5,33	009112	M20	003756	135001	
		FPM	303942								009113				
	S 82, S _L ^V 82, WEH 82, DB 82, MG 82, MK 82	NBR	303904	134738	134739	133976	M24 x 200	730 Nm	003180	78,75 x 5,33	008035	M24	003757	135002	
		FPM	303944								009114				
	S 102, S _L ^V 102, WEH 102 MG 102, MK 102	NBR	303906	134741	134740	133980	M30 x 250	1450 Nm	005582	94,6 x 5,33	009115	M30	003758	135003	
		FPM	303946								009116				
	up to 320 bar	WRD/WRZ/WRH 52 S 52, S _L ^V 52, WEH 52, DB 52, MG 52, MK 52	NBR	303920	133779	133993	133778	M16 x 140	210 Nm	009108	50,16 x 5,33	009345	M16	003755	135004
			FPM	303960								009346			
		S 62, S _L ^V 62, WEH 62, MG 62, MK 62	NBR	303922	133784	133999	133478	M20 x 180	430 Nm	003168	59,7 x 5,33	009112	M20	003756	135005
			FPM	303962								009113			
S 82, S _L ^V 82, WEH 82, DB 82, MG 82, MK 82		NBR	303924	133978	133990	133976	M24 x 200	730 Nm	003180	78,75 x 5,33	008035	M24	003757	135006	
		FPM	303964								009114				
S 102, S _L ^V 102, WEH 102 MG 102, MK 102		NBR	303926	133981	133987	133980	M30 x 250	1450 Nm	005582	94,6 x 5,33	009115	M30	003758	135007	
		FPM	303966								009116				



Mannesmann Rexroth GmbH
D-97813 Lohr am Main
Jahnstraße 3-5 • D-97816 Lohr am Main
Telefon 0 93 52 / 18-0 • Telefax 0 93 52 / 18-10 40
Telex 6 89 418

G.L.Rexroth Ltd.,
Cromwell Road, St. Neots,
Cambridgeshire, PE19 2ES.
Tel: 0480 476041
Fax: 0480 219052