

O6T304

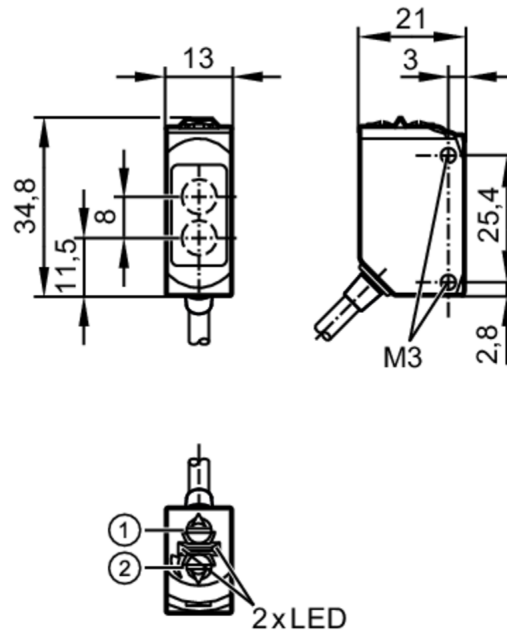

Diffuse reflection sensor

O6T-FNKG



- 1 output function switch
- 1 potentiometer sensitivity
- receiver in upper lens
- transmitter in lower lens



Product characteristics

Type of light	red light
Housing	rectangular

Application

Function principle	Diffuse reflection sensor
--------------------	---------------------------

Electrical data

Operating voltage	[V]	10...30 DC
Current consumption	[mA]	16; ((24 V))
Protection class		III
Reverse polarity protection		yes
Type of light		red light
Wave length	[nm]	633

Outputs

Electrical design		NPN
Output function		light-on/dark-on mode; (selectable)
Max. voltage drop switching output DC	[V]	2.5
Permanent current rating of switching output DC	[mA]	100
Switching frequency DC	[Hz]	1000
Short-circuit protection		yes
Type of short-circuit protection		pulsed

O6T304



Diffuse reflection sensor

O6T-FNKG

Detection zone		
Range	[mm]	5...500; (white paper 200 x 200 mm 90% remission)
Range adjustable		yes
Max. light spot diameter	[mm]	15
Light spot dimensions refer to		at maximum range
Monitoring range final value	[mm]	100...500
Operating conditions		
Ambient temperature	[°C]	-25...80
Protection		IP 65; IP 67; IP 68; IP 69K
Tests / approvals		
EMC		EN 60947-5-2
MTTF	[years]	910
UL approval	voltage supply	Class 2
	UL Approval no.	E003
Mechanical data		
Weight	[g]	80.9
Housing		rectangular
Materials		housing: stainless steel (1.4404 / 316L); plastics: PPSU; Sealing: EPDM
Lens material		PMMA
Lens alignment		side lens
Displays / operating elements		
Display	switching status	1 x LED, yellow
	operation	1 x LED, green
Remarks		
Pack quantity		1 pcs.

O6T304



Diffuse reflection sensor

O6T-FNKG

Electrical connection

Cable: 2 m, PVC; 3 x 0.25 mm²

Connection

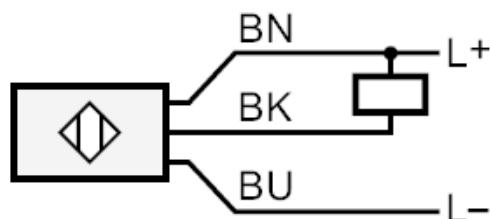

Core colours :

BN = brown
BK = black
BU = blue

Diagrams and graphs

excess gain graph

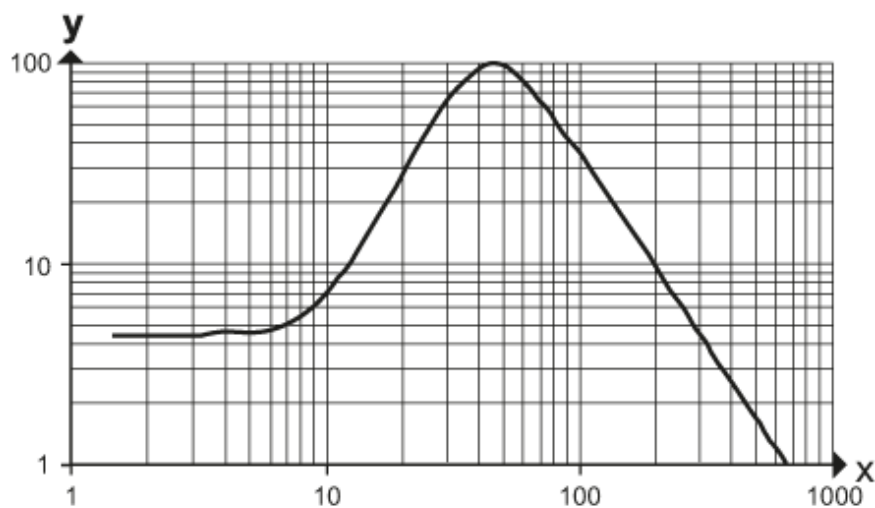

x: distance [mm]

y: excess gain factor