

TELUX™

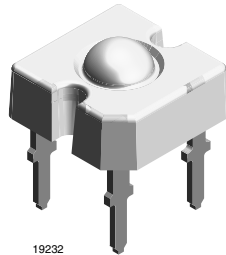

19232

DESCRIPTION

The VLWTG9600 is a clear, non diffused LED for applications where supreme luminous flux is required. It is designed in an industry standard 7.62 mm square package utilizing highly developed InGaN technology. The supreme heat dissipation of VLWTG9600 allows applications at high ambient temperatures. All packing units are binned for luminous flux, forward voltage and color to achieve the most homogenous light appearance in application.

FEATURES

- Utilizing one of the world's brightest InGaN technologies
- High luminous flux
- Supreme heat dissipation: R_{thJP} is 90 K/W
- High operating temperature:
 $T_{amb} = - 40$ to $+ 110$ °C
- Meets SAE and ECE color requirements for the automobile industry for color red
- Packed in tubes for automatic insertion
- Luminous flux, forward voltage and color categorized for each tube
- Small mechanical tolerances allow precise usage of external reflectors or lightguides
- Lead (Pb)-free device - RoHS-COMPLIANT
- ESD-withstand voltage up to 1 kV acc. to JESD22-A114-B



APPLICATIONS

- Exterior lighting
- Replaces small incandescent lamps
- Traffic signals and signs

PARTS TABLE			
PART	COLOR, LUMINOUS INTENSITY	ANGLE OF HALF INTENSITY ($\pm \varphi$)	TECHNOLOGY
VLWTG9600	True green, $\phi_V = 2500$ mlm (typ.)	30°	InGaN on SiC

ABSOLUTE MAXIMUM RATINGS¹⁾ VLWTG9600				
PARAMETER	TEST CONDITION	SYMBOL	VALUE	UNIT
Reverse voltage	$I_R = 10 \mu A$	V_R	5	V
DC Forward current	$T_{amb} \leq 50$ °C	I_F	50	mA
Surge forward current	$t_p \leq 10 \mu s$	I_{FSM}	0.1	A
Power dissipation		P_V	230	mW
Junction temperature		T_j	100	°C
Operating temperature range		T_{amb}	- 40 to + 100	°C
Storage temperature range		T_{stg}	- 55 to + 100	°C



ABSOLUTE MAXIMUM RATINGS ¹⁾ VLWTG9600				
Soldering temperature	t ≤ 5 s, 1.5 mm from body preheat temperature 100 °C/ 30 sec.	T _{sd}	260	°C
Thermal resistance junction/ambient	with cathode heatsink of 70 mm ²	R _{thJA}	200	K/W
Thermal resistance junction/pin		R _{thJP}	90	K/W

¹⁾ T_{amb} = 25 °C, unless otherwise specified

OPTICAL AND ELECTRICAL CHARACTERISTICS ¹⁾ TRUE GREEN VLWTG9600						
PARAMETER	TEST CONDITION	SYMBOL	MIN	TYP.	MAX	UNIT
Total flux	I _F = 50 mA, R _{thJA} = 200 °K/W	φ _V	2000	2500		mlm
Luminous intensity/Total flux	I _F = 50 mA, R _{thJA} = 200 °K/W	I _V /φ _V		0.7		mcd/mlm
Dominant wavelength	I _F = 50 mA, R _{thJA} = 200 °K/W	λ _d	509	523	535	nm
Peak wavelength	I _F = 50 mA, R _{thJA} = 200 °K/W	λ _p		518		nm
Angle of half intensity	I _F = 50 mA, R _{thJA} = 200 °K/W	φ		± 30		deg
Total included angle	90 % of Total Flux Captured	φ		100		deg
Forward voltage	I _F = 50 mA, R _{thJA} = 200 °K/W	V _F		3.9	5.0	V
Reverse voltage	I _R = 10 μA	V _R	5	10		V
Junction capacitance	V _R = 0, f = 1 MHz	C _j		50		pF
Temperature coefficient of λ _{dom}	I _F = 30 mA	TCλ _{dom}		0.02		nm/K

¹⁾ T_{amb} = 25 °C, unless otherwise specified

LUMINOUS INTENSITY CLASSIFICATION		
GROUP	TRUE GREEN	
	LUMINOUS FLUX (MLM)	
	MIN.	MAX.
D	2000	3000
E	2500	3600
F	3000	4200

COLOR CLASSIFICATION		
GROUP	TRUE GREEN	
	DOM. WAVELENGTH (NM)	
	MIN.	MAX.
2	509	517
3	515	523
4	521	529
5	527	535

TYPICAL CHARACTERISTICS

$T_{amb} = 25\text{ }^{\circ}\text{C}$, unless otherwise specified

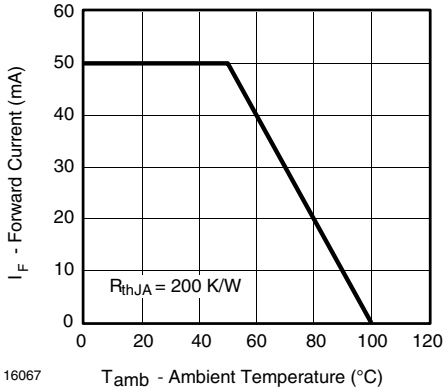

Figure 1. Forward Current vs. Ambient Temperature for InGaN

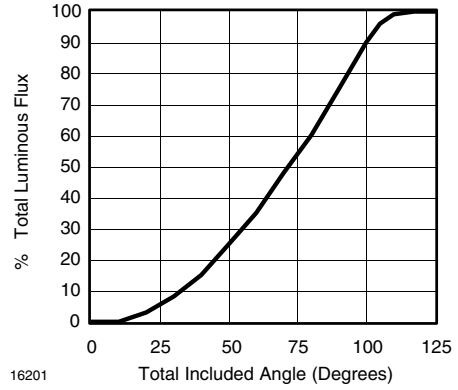

Figure 4. Percentage Total Luminous Flux vs. Total Included Angle for 90° emission angle

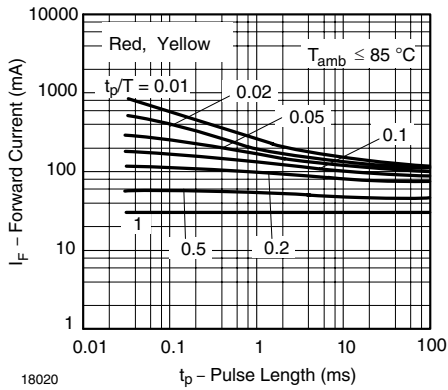

Figure 2. Forward Current vs. Pulse Length

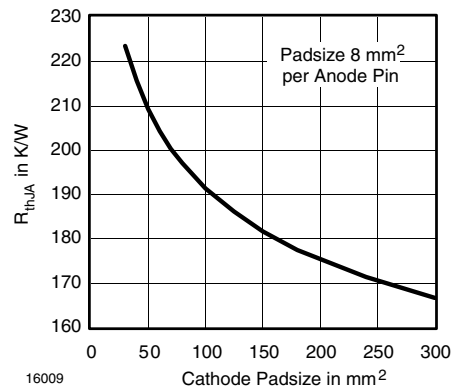

Figure 5. Thermal Resistance Junction Ambient vs. Cathode Padsize

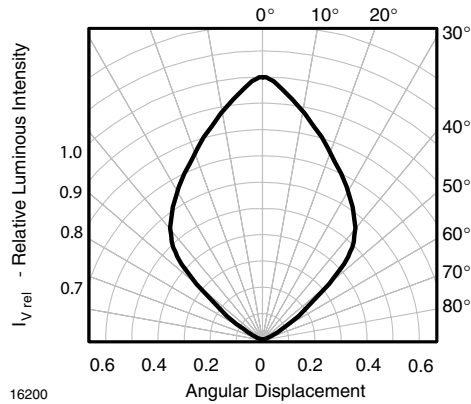

Figure 3. Rel. Luminous Intensity vs. Angular Displacement

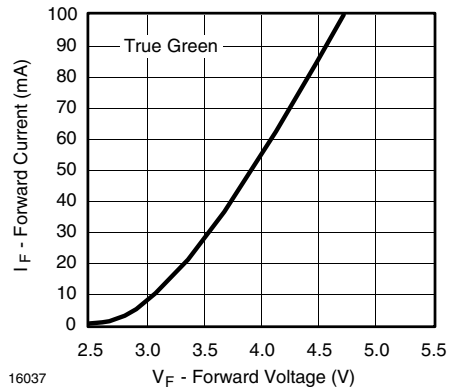

Figure 6. Forward Current vs. Forward Voltage

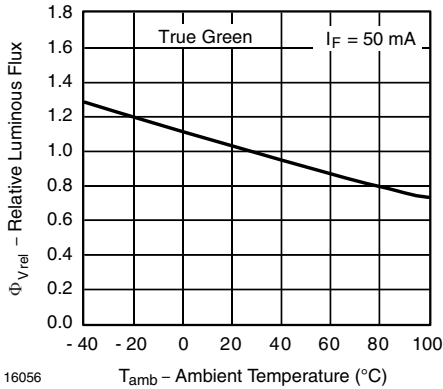

Figure 7. Rel. Luminous Flux vs. Ambient Temperature

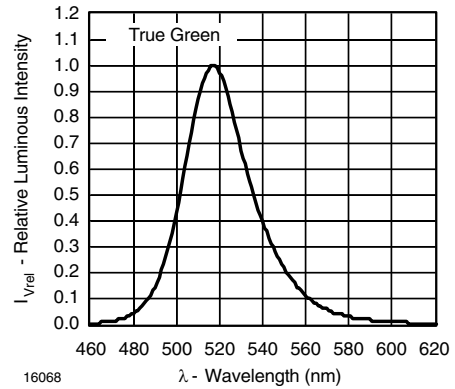

Figure 10. Relative Intensity vs. Wavelength

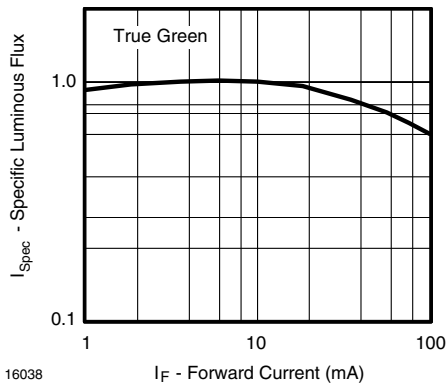

Figure 8. Specific Luminous Flux vs. Forward Current

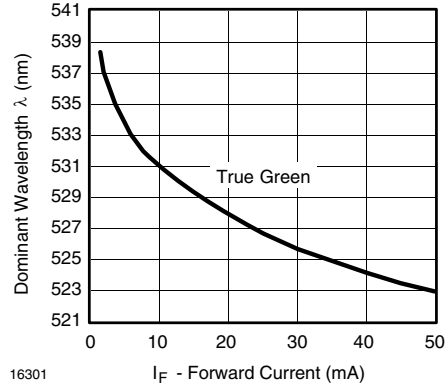

Figure 11. Dominant Wavelength vs. Forward Current

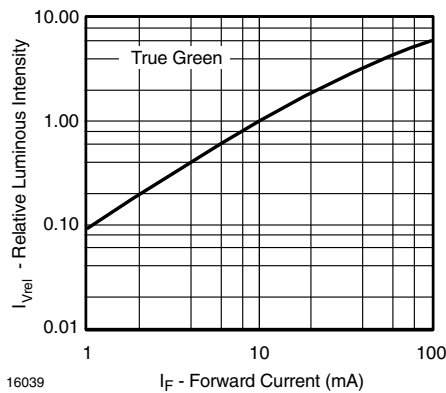
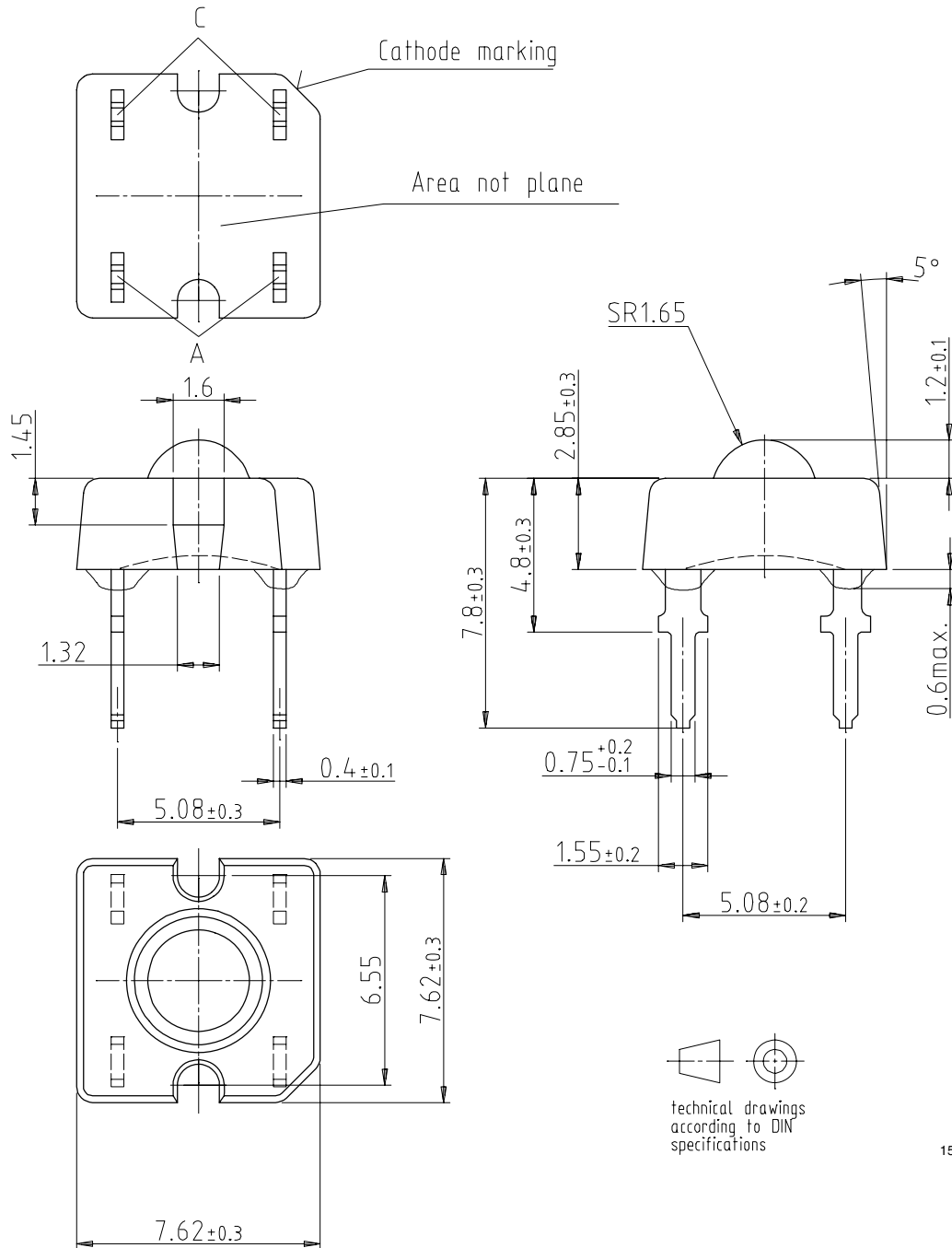

Figure 9. Relative Luminous Flux vs. Forward Current

PACKAGE DIMENSIONS IN MM



15984

FAN FOLD BOX

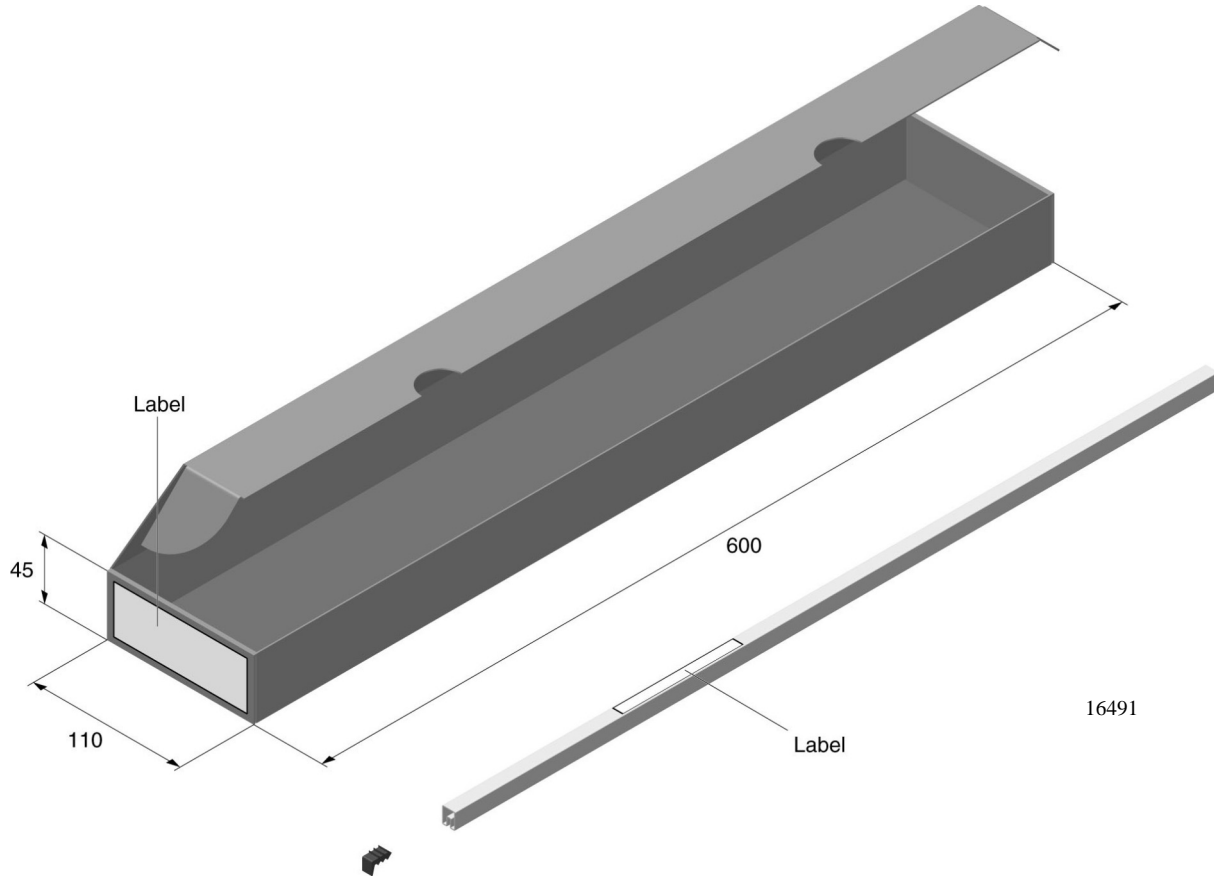

LABEL OF FAN FOLD BOX

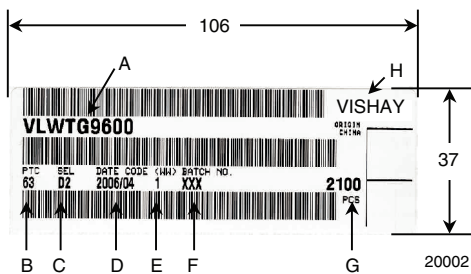

- A) Type of component
- B) Manufacturing Plant
- C) SEL - Selection Code (Bin):
e.g.: D = Code for Luminous Intensity Group
2 = Code for Color Group
- D) Date Code year/week
- E) Day Code (e.g. 1: Monday)
- F) Batch No.
- G) Total quantity
- H) Company Code

EXAMPLE FOR TELUX TUBE LABEL

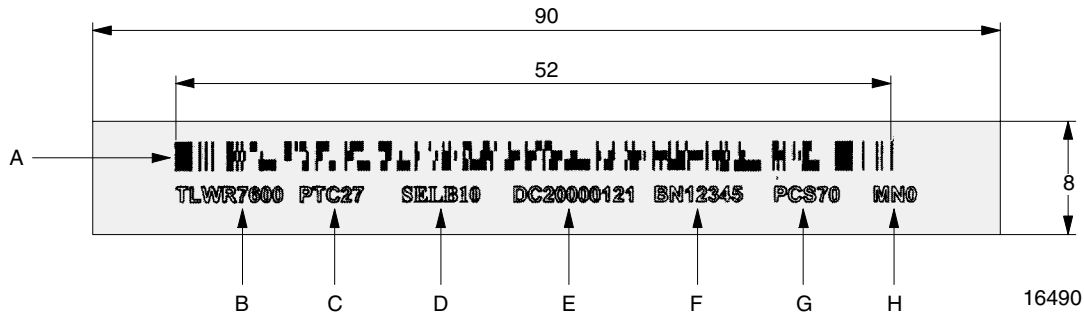

- A) Bar code
- B) Type of component
- C) Manufacturing plant
- D) SEL – Selection code (Bin)
Digit1 – code for Luminous Flux group
Digit2 – code for Dominant Wavelength group
Digit3 – code for Forward Voltage group
- E) Date code
- F) Batch No.
- G) Total quantity
- H) Company code

TUBE WITH BAR CODE LABEL

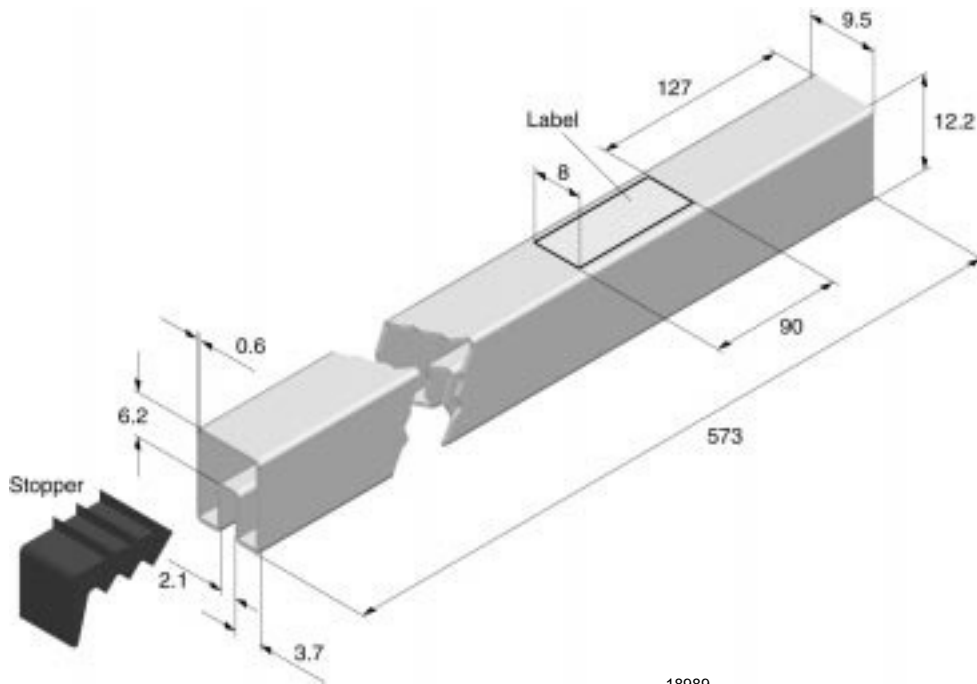

18989

Drawing proportions not scaled

OZONE DEPLETING SUBSTANCES POLICY STATEMENT

It is the policy of Vishay Semiconductor GmbH to

1. Meet all present and future national and international statutory requirements.
2. Regularly and continuously improve the performance of our products, processes, distribution and operating systems with respect to their impact on the health and safety of our employees and the public, as well as their impact on the environment.

It is particular concern to control or eliminate releases of those substances into the atmosphere which are known as ozone depleting substances (ODSs).

The Montreal Protocol (1987) and its London Amendments (1990) intend to severely restrict the use of ODSs and forbid their use within the next ten years. Various national and international initiatives are pressing for an earlier ban on these substances.

Vishay Semiconductor GmbH has been able to use its policy of continuous improvements to eliminate the use of ODSs listed in the following documents.

1. Annex A, B and list of transitional substances of the Montreal Protocol and the London Amendments respectively
2. Class I and II ozone depleting substances in the Clean Air Act Amendments of 1990 by the Environmental Protection Agency (EPA) in the USA
3. Council Decision 88/540/EEC and 91/690/EEC Annex A, B and C (transitional substances) respectively.

Vishay Semiconductor GmbH can certify that our semiconductors are not manufactured with ozone depleting substances and do not contain such substances.

We reserve the right to make changes to improve technical design
and may do so without further notice.

Parameters can vary in different applications. All operating parameters must be validated for each customer application by the customer. Should the buyer use Vishay Semiconductors products for any unintended or unauthorized application, the buyer shall indemnify Vishay Semiconductors against all claims, costs, damages, and expenses, arising out of, directly or indirectly, any claim of personal damage, injury or death associated with such unintended or unauthorized use.

Vishay Semiconductor GmbH, P.O.B. 3535, D-74025 Heilbronn, Germany



Notice

Specifications of the products displayed herein are subject to change without notice. Vishay Intertechnology, Inc., or anyone on its behalf, assumes no responsibility or liability for any errors or inaccuracies.

Information contained herein is intended to provide a product description only. No license, express or implied, by estoppel or otherwise, to any intellectual property rights is granted by this document. Except as provided in Vishay's terms and conditions of sale for such products, Vishay assumes no liability whatsoever, and disclaims any express or implied warranty, relating to sale and/or use of Vishay products including liability or warranties relating to fitness for a particular purpose, merchantability, or infringement of any patent, copyright, or other intellectual property right.

The products shown herein are not designed for use in medical, life-saving, or life-sustaining applications. Customers using or selling these products for use in such applications do so at their own risk and agree to fully indemnify Vishay for any damages resulting from such improper use or sale.