

# CX. | Lever latches with key

Safety lock, zinc alloy



## LOCK

With opposing blades and double track key with internal profile.

## STATOR

Glossy chrome-plated zinc alloy.

## ROTOR

Chrome-plated zinc alloy with drill-proof hardened steel plate and stainless steel front plate.

## NUT

M19x1 in brass.

## SPRING WASHER

Zinc-plated steel.

## CLOSING LEVER

Zinc-plated steel, thickness 2.5 mm.

## SCREW

M5x5 zinc-plated steel.

## TWO REVERSIBLE KEYS

Nickel-plated brass, removable in two positions at 180°.

## ROTATION

180°.

## IP PROTECTION

IP 65 protection class, according to EN 60529 (see page A-18).

## STANDARD EXECUTIONS

- **CXA/CXB**: lock with 15,660 different combinations: each lock has a couple of keys with different combination.
- **CXAU/CXBU**: lock with one combination. All locks have the same combination and can be opened with the same key.

## SPECIAL EXECUTIONS AND ACCESSORIES

- Closing levers in other dimensions.
- Brass threaded extension for prolonged positioning of the lever (code 421137 C.PQ M5/58).



Drilling templates

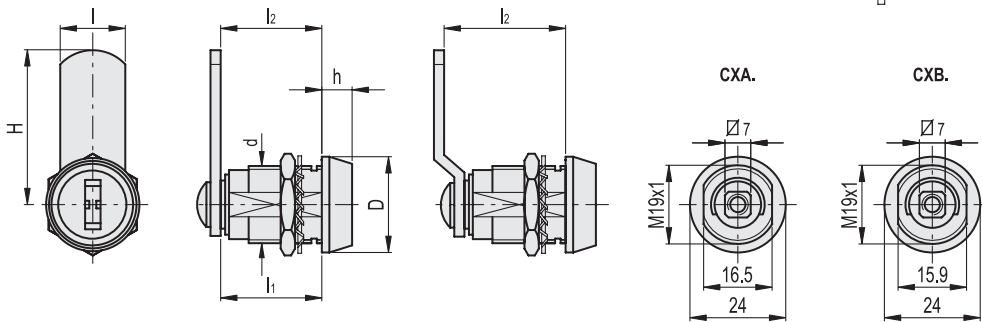
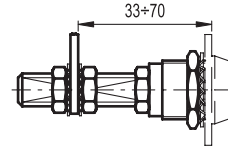
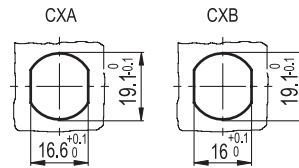

## CX.

Code	Description	D	H	d	l	l1	l2	h	△
421611	CXA.32-23	24	32	M19x1	16	22.5	22.5	7	60
421615	CXA.36-28	24	35.5	M19x1	16	22.5	27.5	7	62
421619	CXB.32-23	24	32	M19x1	16	22.5	22.5	7	60
421623	CXB.36-28	24	35.5	M19x1	16	22.5	27.5	7	62

## CXU.

Code	Description	D	H	d	l	l1	l2	h	△
421613	CXAU.32-23	24	32	M19x1	16	22.5	22.5	7	60
421617	CXAU.36-28	24	35.5	M19x1	16	22.5	27.5	7	62
421621	CXBU.32-23	24	32	M19x1	16	22.5	22.5	7	60
421625	CXBU.36-28	24	35.5	M19x1	16	22.5	27.5	7	62

