

**STANDARD EXECUTIONS**

- **TLA:** basic hook clamp.
  - **TLAL:** hook clamp with padlock hole.
  - **TLAS:** hook clamp with security stop and technopolymer push button in RAL 3000 red colour or with stainless steel spring.
- Indexes for materials and treatments to add to the above-mentioned standard executions:
- **Z:** lever body and bracket in zinc-plated steel.
  - **SST:** lever body and bracket in AISI 304 stainless steel.
  - **NH:** lever body and bracket in nickel-plated steel.

**SPECIAL EXECUTIONS ON REQUEST**

- Hook clamps in unplated steel.
- Catch brackets in different shapes and finishes.



TLA  
TLA.SST

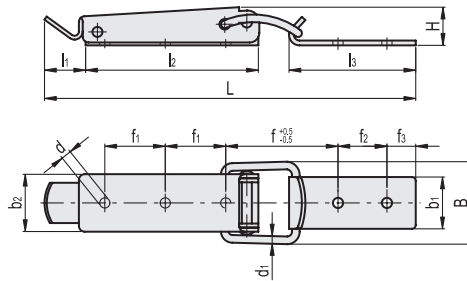

**TLA.Z**

Code	Description	b2	L	B	H	d	d1	b1	l1	l2	l3	f	f1	f2	f3	Max. working load [N]	Load at breakage [N]	Δ
420081	TLA.Z-16.4/102+R	16.4	102	23	11	3.2	2	13	16	44	30	34.5	12.5	12	5	550	1200	31
420061	TLA.Z-23/140.5+R	23	140.5	34	12.5	4.1	3	19	16	70	43	38	22.5	20	8	1500	3000	78
420051	TLA.Z-30/193.5+R	30	193.5	43	19	5.3	4	27	21.5	90	66	58.5	31.5	25.5	15	2000	4000	188

**TLA.SST**



Code	Description	b2	L	B	H	d	d1	b1	l1	l2	l3	f	f1	f2	f3	Max. working load [N]	Load at breakage [N]	Δ
420082	TLA.SST-16.4/102+R	16.4	102	23	11	3.2	2	13	16	44	30	34.5	12.5	12	5	550	1200	31
420062	TLA.SST-23/140.5+R	23	140.5	34	12.5	4.1	3	19	16	70	43	38	22.5	20	8	1500	3000	78
420052	TLA.SST-30/193.5+R	30	193.5	43	19	5.3	4	27	21.5	90	66	58.5	31.5	25.5	15	2000	4000	188

TLAL  
TLAL.SST

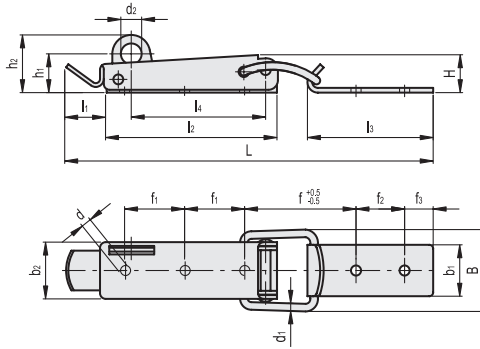

TLAL.Z

Code	Description	b2	L	B	H	d	d1	d2	b1	l1	l2	l3	l4	f	f1	f2	f3	h1	h2	Max. working load [N]	Load at breakage [N]	⚖️
420085	TLAL.Z-16.4/102+R	16.4	102	23	11	3.2	2	4	13	16	44	30	34.5	34.5	12.5	12	5	11.5	15.5	550	1200	32
420063	TLAL.Z-23/140.5+R	23	140.5	34	12.5	4.1	3	7	19	16	70	43	55	38	22.5	20	8	13	20	1500	3000	79
420053	TLAL.Z-30/193.5+R	30	193.5	43	19	5.3	4	11	27	21.5	90	66	71	58.5	31.5	25.5	15	20.5	30.5	2000	4000	189

TLAL.SST

INOX STAINLESS STEEL

Code	Description	b2	L	B	H	d	d1	d2	b1	l1	l2	l3	l4	f	f1	f2	f3	h1	h2	Max. working load [N]	Load at breakage [N]	⚖️
420086	TLAL.SST-16.4/102+R	16.4	102	23	11	3.2	2	4	13	16	44	30	34.5	34.5	12.5	12	5	11.5	15.5	550	1200	32
420064	TLAL.SST-23/140.5+R	23	140.5	34	12.5	4.1	3	7	19	16	70	43	55	38	22.5	20	8	13	20	1500	3000	79
420054	TLAL.SST-30/193.5+R	30	193.5	43	19	5.3	4	11	27	21.5	90	66	71	58.5	31.5	25.5	15	20.5	30.5	2000	4000	189

TLAS.NH-30/193.5+R  
TLAS.SST-30/193.5+R

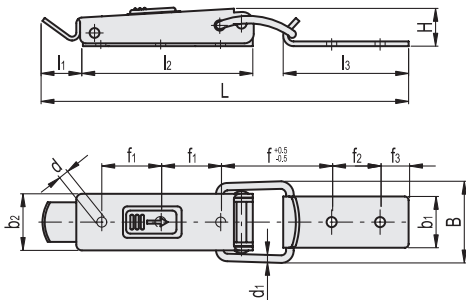

TLAS.Z-16.4/102+R  
TLAS.SST-16.4/102+R

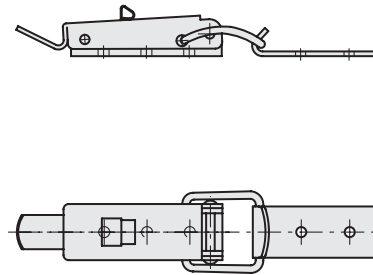

TLAS.

Code	Description	b2	L	B	H	d	d1	b1	l1	l2	l3	f	f1	f2	f3	Max. working load [N]	Load at breakage [N]	⚖️
420083	TLAS.Z-16.4/102+R	16.4	102	23	11	3.2	2	13	16	44	30	34.5	12.5	12	5	550	1200	32
420055	TLAS.NH-30/193.5+R	30	193.5	43	19	5.3	4	27	21.5	90	66	58.5	31.5	25.5	15	2000	4000	189

TLAS.SST

INOX STAINLESS STEEL

Code	Description	b2	L	B	H	d	d1	b1	l1	l2	l3	f	f1	f2	f3	Max. working load [N]	Load at breakage [N]	⚖️
420084	TLAS.SST-16.4/102+R	16.4	102	23	11	3.2	2	13	16	44	30	34.5	12.5	12	5	550	1200	32
420056	TLAS.SST-30/193.5+R	30	193.5	43	19	5.3	4	27	21.5	90	66	58.5	31.5	25.5	15	2000	4000	189



Latches