

**TOP VIEW**

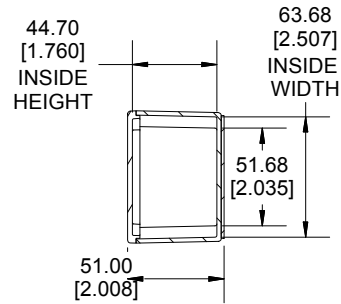

**SECTION A-A  
END VIEW**

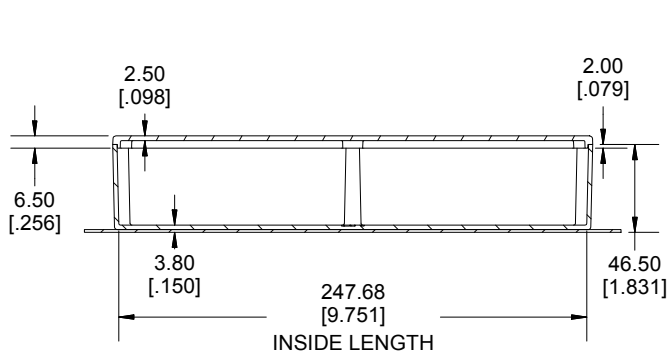
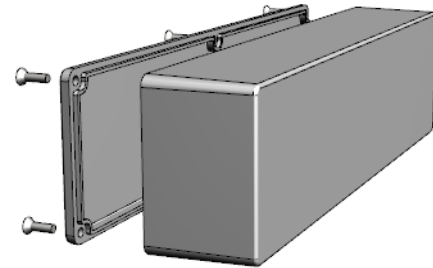
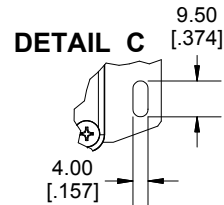

**SECTION B-B  
SIDE VIEW**

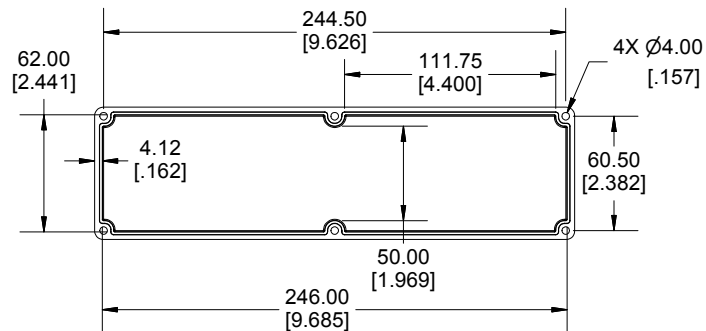
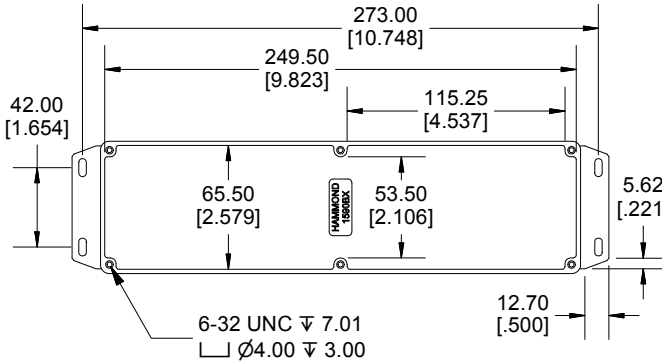

**INSIDE LID**

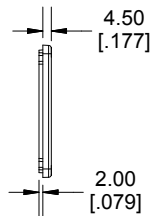

Enclosures can be Factory Modified ( Milling, Drilling, Printing etc.)  
 Contact Factory [mjm@hammondmfg.com](mailto:mjm@hammondmfg.com) for quotes  
 Solid models of this enclosure available in STEP or IGES.  
 (Part number and text placement/orientation on our products are subject to change,  
 we do not recommend using them as a locating reference for modification purposes)

**NOTE**

Purchased assembly includes box, lid and 6 cover screws.  
 Box and lid are made from Diecast Aluminum Alloy.  
 Silicone Gasket supplied with liquid resistant enclosure.

**Recommended Torque: 50-55 cN.m [71-78 ozf.in]**

**Recommended Torque with Gasket : 25-30 cN.m [36-43 ozf.in]**

**PART NUMBERS**

<b>1590BXF Enclosure</b>	
Natural Finish Enclosure	1590BXF
Black Textured Enclosure	1590BXFBK
<b>1590BXF Liquid Resistant Enclosure (Silicone Gasket)</b>	
Natural Finish Enclosure	1590WBXF
Black Textured Enclosure	1590WBXFBK

**ACCESSORIES**

**Liquid Resistant Cover Screws**

Stainless Steel Cover Screws (Pkg 100) [6-32 x 1/2" With O-Ring]	1590WMS100
Black Stainless Steel Cover Screws (Pkg 100) [6-32 x 1/2" With O-Ring]	1590WMS100BK

**Standard Cover Screws**

Plated Cover Screws (Pkg 100) [6-32 x 1/2"]	1590MS100
Black Cover Screws (Pkg 100) [6-32 x 1/2"]	1590MS100BK

Dimensions:  
mm  
[inches]

**HAMMOND  
MANUFACTURING®**

**1590BXF**

[www.hammondmfg.com](http://www.hammondmfg.com)