

DATA SHEET

GAS DISCHARGE TUBES TELEPHONE INTERFACE

2R-5-ST5 series

RoHS compliant & free



Product specification— February 02, 2021 V.1



Gas Discharge Tube (GDT) Data Sheet

Features

- Provide ultra-fast response to surge voltage from slow-rising surge of 100V/s to rapid-rising surge of 1KV/μs
- Stable breakdown voltage
- High insulation resistance
- Low capacitance (≤1.0pF)
- High holdover voltage
- Large absorbing transient current capability
- Micro-Gap Design
- Size: 5.0mm*5.0mm
- Storage and operational temperature: -40°C ~ +85°C
- Meets MSL level 1, per J-STD-020
- Safety certification: UL



Applications

- Repeaters, Modems.
- Telephone Interface, Line cards.
- Data communication equipment.
- Line test equipment

Part Number Code

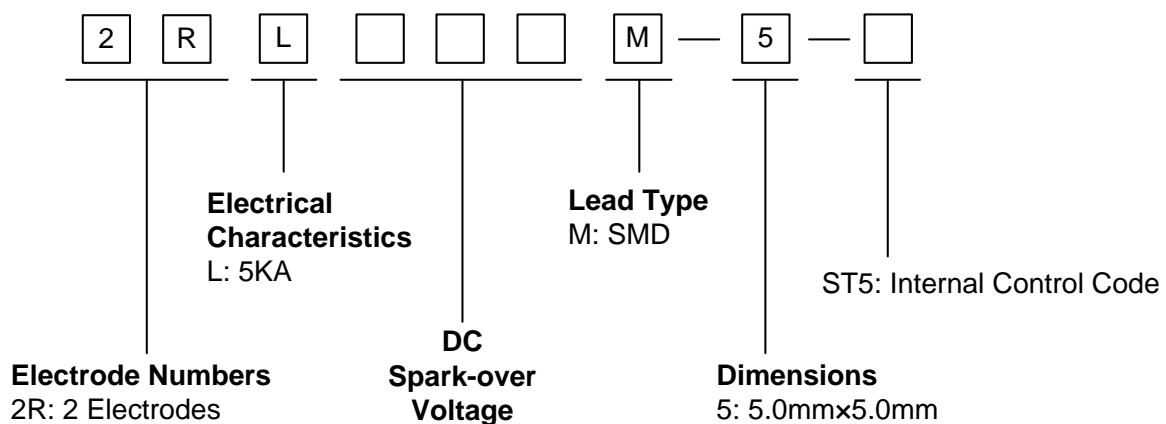

Marking

- B** : BrightKing Logo
- 2RL090-5 : Device Marking Code
- XXXX : Internal Control Code

Dimensions

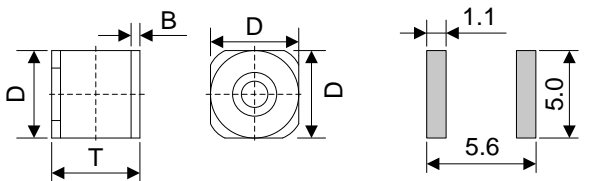
M Type 	Symbol	Dimension (mm)	
		Spec.	Tolerance
	D	5.0	±0.2
	T	5.0	±0.3
B	0.5	±0.1	

Electrical Characteristics

Part Number	Type ①	DC Spark-over Voltage	Maximum Impulse Spark-over Voltage	Nominal Impulse Discharge Current	Alternating Discharge Current	Impulse Life	Minimum Insulation Resistance		Maximum Capacitance	Device Marking Code
		100V/s	1000V/μs	8/20μs 10times	50Hz, 1sec	10/1000μs 100A	Test Voltage	(GΩ)	1MHz	
		(V)	(V)	(KA)	(A)	(times)	DC(V)		(pF)	
2RL090M-5	ST5	90±20%	650	5.0	5.0	300	50	1.0	1.0	2RL090-5
2RL150M-5	ST5	150±20%	700	5.0	5.0	300	100	1.0	1.0	2RL150-5
2RL230M-5	ST5	230±20%	700	5.0	5.0	300	100	1.0	1.0	2RL230-5
2RL250M-5	ST5	250±20%	700	5.0	5.0	300	100	1.0	1.0	2RL250-5
2RL300M-5	ST5	300±20%	900	5.0	5.0	300	100	1.0	1.0	2RL300-5
2RL350M-5	ST5	350±20%	900	5.0	5.0	300	100	1.0	1.0	2RL350-5
2RL400M-5	ST5	400±20%	1000	5.0	5.0	300	100	1.0	1.0	2RL400-5
2RL470M-5	ST5	470±20%	1100	5.0	5.0	300	250	1.0	1.0	2RL470-5

Notes: ① Specific code by request.

Electrical Ratings

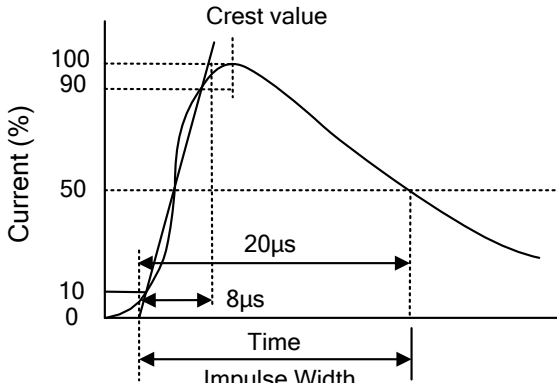
Items	Test Condition/Description	Requirement
DC Spark-over Voltage	The voltage is measured with voltage ramp $dv/dt=100V/s$.	To meet the specified value
Maximum Impulse Spark-over Voltage	The maximum impulse spark-over voltage is measured with voltage ramp $dv/dt=1000V/\mu s$.	
Impulse Discharge Current	Maximum 8/20μs surge current that can be applied between two electrodes, 5 positive and 5 negative surges, with 3 minutes interval time. 	

Alternating Discharge Current	Rated RMS value of AC current at 50Hz, 1 sec. for 10 times with interval time 3 min.
Insulation Resistance	The resistance of gas tube shall be measured between two electrodes.
Capacitance	The capacitance of gas tube shall be measured between two electrodes. Test frequency: 1MHz

Recommended Soldering Conditions

Reflow Soldering

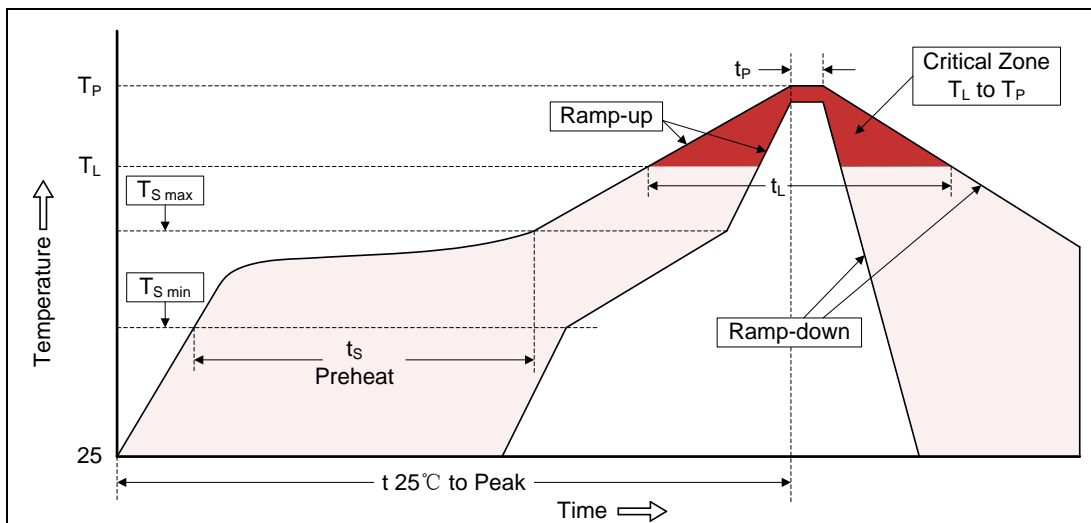

Profile Feature	Pb-Free Assembly
Average ramp-up rate (T_L to T_P)	3°C/second max.
Preheat -Temperature Min ($T_{S\ min}$) -Temperature Max ($T_{S\ max}$) -Time (min to max) (t_s)	150°C 200°C 60-180 seconds
$T_{S\ max}$ to T_L -Ramp-up Rate	3°C/second max.
Time maintained above: -Temperature (T_L) -Time (t_L)	217°C 60-150 seconds
Peak Temperature (T_P)	260°C
Time within 5°C of actual Peak Temperature (t_P)	20-40 seconds
Ramp-down Rate	6°C/second max.
Time 25°C to Peak Temperature	8 minutes max.

Packaging

Tape	Dimension (mm)	
	Symbol	Spec. / Tolerance
	W	12.00 ±0.20
	P0	4.00 ±0.10
	P	8.00 ±0.10
	P1	2.00 ±0.10
	D	1.55 ±0.10
	E	1.75 ±0.10
	F	5.50 ±0.10
	A0	5.40 ±0.10
	K0	5.40 ±0.10
	B0	5.40 ±0.10
	t	0.40 ±0.10
	D	330.00 ±1.00
		d
L		20.00 ±0.50
t		2.00 ±0.20
Quantity: 800pcs		