

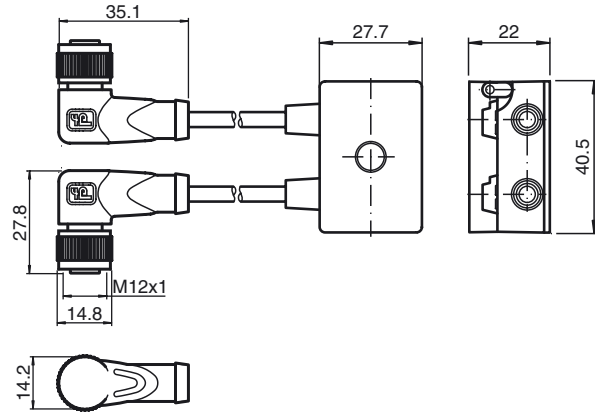

Dimensions

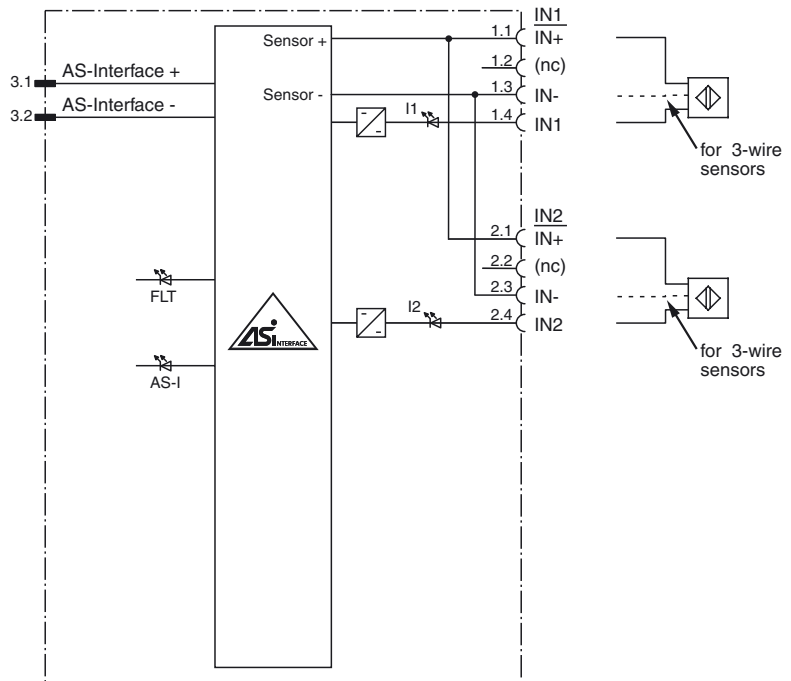

Electrical connection



Model number

VBA-2E-G10-ZEJ-1M-2V1-W

G10 ultra compact module
2 inputs, 2 x M12 socket

Features

- Ultra-compact enclosure
- Gold-plated and machined contacts
- One piece housing
- Protection degree IP68/IP69K
- Direct connection via cable outlet

Function

The AS-Interface G10 ultra-compact module is suitable for the remote connection of sensors within very limited space. The one-piece enclosure has the protection degree IP68/IP69K.

The AS-Interface flat cable is contacted via pointy, gold-plated contact pins. The exact location of the pins on the lead is ensured by the swivel mechanism. Sensors are connected to the module via M12 sockets.

Multiple LEDs indicate the current status of the AS-Interface strand and the inputs and are used for diagnosis. The ultra-compact module is powered from the AS-Interface strand.

Indicating / Operating means

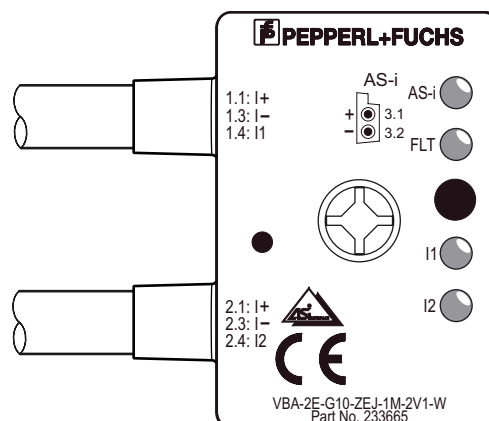

Release date: 2013-12-19 13:38 Date of issue: 2013-12-19 233665_eng.xml

Accessories

VAZ-PK-FK-0,2M-V1-W

Adapter cable G10 module/hand-held programming device

Technical data**General specifications**

Slave type	A/B slave
AS-Interface specification	V3.0
Required master specification	≥ V2.0
UL File Number	E223772 "For use in NFPA 79 Applications only"

Indicators/operating means

LED FAULT	error display; LED red red: communication error or address is 0 red flashing: overload of sensor power supply or outputs
LED AS-i	AS-Interface voltage; LED green
LED IN	switching state (input); 2 LED yellow

Electrical specifications

Rated operating voltage	U_e	18.5 ... 31.6 V from AS-Interface
Rated operating current	I_e	≤ 40 mA (without sensors) / max. 120 mA
Protection class		III

Input

Number/Type	2 inputs for 2- or 3-wire sensors (PNP), DC
Supply	from AS-Interface
Voltage	21 ... 31 V
Current loading capacity	75 mA at $T_B \leq 40^\circ\text{C}$ (104 °F) 60 mA at $T_B \leq 75^\circ\text{C}$ (167 °F) overload and short-circuit resistant
Input current	≤ 9 mA (limited internally)
Switching point	according to DIN EN 61131-2 (Type 2)
0 (unattenuated)	≤ 3 mA
1 (attenuated)	≥ 5 mA
Signal delay	< 1 ms (input/AS-Interface)

Programming instructions

Profile	S-0.A.2
IO code	0
ID code	A
ID1 code	7
ID2 code	2

Data bits (function via AS-Interface)	input	output
D0	IN1	-
D1	IN2	-
D2	-	-
D3	-	-

Parameter bits (programmable via AS-i) function

P0	not used
P1	Input filter P1 = 0 input filter on, pulse suppression ≤ 2 ms P1 = 1 input filter off (basic setting)
P2	Synchronous mode P2 = 0 synchronous mode on P2 = 1 synchronous mode off (basic setting)
P3	not used

Ambient conditions

Ambient temperature	-25 ... 70 °C (-13 ... 158 °F)
Storage temperature	-25 ... 85 °C (-13 ... 185 °F)
Shock and impact resistance	30 g, 11 ms in 6 spatial directions 3 shocks 10 g, 16 ms in 6 spatial directions 1000 shocks
Vibration resistance	0.75 mm 10 ... 57 Hz, 5 g 57 ... 150 Hz, 20 cycles

Mechanical specifications

Protection degree	IP67 IP67 / IP68 / IP69K with flat cable VAZ-FK-S*
Connection	AS-Interface: AS-Interface flat cable Inputs & matching connector: M12 round connector, 4-pin, A-coded, according to IEC 61076-2-101:2012
Material	
Contacts	CuSn / Au
Housing	PBT PC
Body	black PUR
Cable	PUR
Mounting screw	Stainless steel 1.4305 / AISI 303
Cable	
Sheath diameter	Ø4,3 mm
Color	black
Cores	4 x 0.34 mm ²
Length	L 1 m
Mass	100 g
Tightening torque, fastening screws	1.65 Nm
Tightening torque, cable gland	0.4 Nm

Compliance with standards and directives

Directive conformity	
----------------------	--

EMC Directive 2004/108/EC	EN 50295:1999
Standard conformity	
Noise immunity	EN 61000-6-2:2005, EN 61326-1:2006, EN 50295:1999
Emitted interference	EN 61000-6-4:2007
Input	EN 61131-2:2007
Protection degree	EN 60529:2000
Fieldbus standard	EN 50295:1999, IEC 62026-2:2006

Approvals and certificates

UL approval	cULus Listed, Type 1 enclosure
Maximum permissible ambient temperature	≤ 65 °C (≤ 149 °F)

Notes

Do not connect inputs and outputs, which are supplied via the module from AS-interface or via auxiliary power, with power supply and signal circuits with external potentials.

Mounting instructions

You may screw the device onto a level mounting surface using two M4 attachment screws. The attachment screws are not included.

