

## Single-Strand Roller Chains, similar to DIN ISO 606 (formerly DIN 8187), with straight plates

**Material:** Special chain steel.

High-quality simplex roller chains, pre-stretched according to DIN. Notes regarding the performance calculation on page 41. With straight link plates, to use as conveyor chain or drive chain. Chains are supplied with an uneven number of links, with inner links at both ends. Connecting links must be ordered separately.

**Temperature range:** -20°C to +120°C.  
Other temperatures are possible if special grease is used.

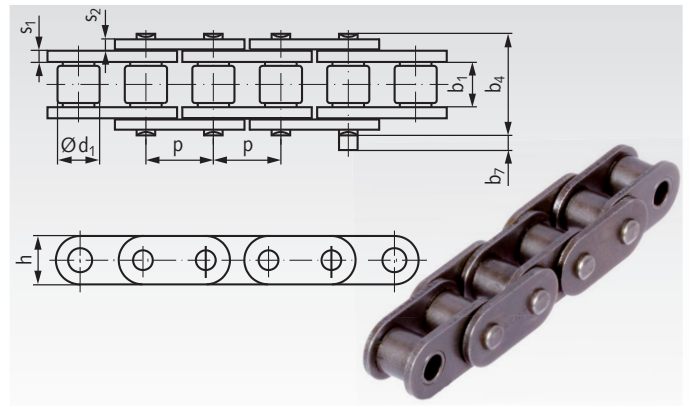

Ordering Details: e.g.:

Product No. 101 000 00, Roller Chain 06 B-1, with straight plates or  
Product No. 105 000 00GL, Roller Chain 08 B-1-GL, with straight plates

DIN ISO-No.	Product No.	Pitch x Inner Width		Plate Height h max. mm	Plate Thickness s <sub>1</sub> /s <sub>2</sub> max. mm	Roller-Ø d <sub>1</sub> mm	Pin Ø mm	Width over Pin b <sub>4</sub> mm	Projection over link b <sub>7</sub> <sup>1)</sup> mm	Breaking Load min. kN	Weight kg/m	
		mm	inch									
06 B-1	101 000 00*	9,525	x 5,72	3/8 x 7/32	8,26	1,405	6,35	3,28	13,5	3,3	8,9	0,41
08 B-1-GL	105 000 00GL	12,7	x 7,75	1/2 x 5/16	11,8	1,60	8,51	4,45	16,7	1,5	17,8	0,80
10 B-1-GL	106 000 00GL	15,875	x 9,65	5/8 x 3/8	14,7	1,70	10,16	5,08	19,5	2,4	22,2	1,06
12 B-1-GL	107 000 00GL	19,05	x 11,68	3/4 x 7/16	16,0	1,85	12,07	5,72	22,5	2,7	28,9	1,32
16 B-1-GL	108 000 00GL	25,4	x 17,02	1" x 17,02mm	21,0	4,15/3,1	15,88	8,28	36,1	3,0	60,0	3,08
16 B-1-GLH	108 000 00GLH	25,4	x 17,02	1" x 17,02mm	24,0	4,15/3,1	15,88	8,28	36,1	3,0	60,0	3,49
20 B-1-GL	109 000 00GL	31,75	x 19,56	1 1/4 x 3/4	26,4	4,50/3,5	19,05	10,19	43,2	3,7	95,0	4,16

<sup>1)</sup> Maximum value at the connecting link.

\* Standard chain DIN ISO 606.

### Attention please: Packing Unit 5m

If special lengths are needed, please tell us the length and the number of links (uneven number!). Connecting links have to be ordered separately.

## Connecting Links for Single-Strand Roller Chains similar to DIN ISO 606 (formerly DIN 8187), with straight plates

**Materials:** Special chain steel. **Attention please:** Product numbers marked with \* are in packing units of 5 pieces.

Ordering Details: e.g.: Product No. 105 003 00GL, Connecting Link No.11/E, 08 B-1-GL with straight plates



DIN ISO No.	Product No. Connect. Link No. 11/E	Weight g	Product No. Cranked No. 12/L <sup>1)</sup>	Weight g	Product No. Inner Link No. 4/B	Weight g
08 B-1-GL	105 003 00GL*	10	105 004 00	9	105 001 00GL	10
10 B-1-GL	106 003 00GL*	17	106 004 00	15	106 001 00GL	18
12 B-1-GL	107 003 00GL*	23	107 004 00	24	107 001 00GL	28
16 B-1-GL	108 003 00GL <sup>2)</sup>	72	108 004 00	80	108 001 00GL	83
16 B-1-GLH	108 003 00GLH <sup>2)</sup>	78	-	-	108 001 00GLH	93
20 B-1-GL	109 003 00GL <sup>2)</sup>	126	109 004 00	145	109 001 00GL	141

<sup>1)</sup> With cranked links power and breaking loads are reduced by 20%.

<sup>2)</sup> With cottered pin.

\* Delivery in packing units of 5 pieces.