

- High power density power supply (open frame)
- Certification according to IEC/EN/ES 60601-1 3rd edition for 2×MOPP
- Low leakage current <100 µA rated for BF applications
- EMC emission and immunity to IEC 60601-1-2 edition 4
- Risk management process according to ISO 14971 including risk management file
- Acceptance criteria for electronic assemblies according to IPC-A-610 Level 3
- Protection class I and II
- Operating up to 5000m altitude
- Ready to meet ErP directive, no load power consumption
- 5 year product warranty

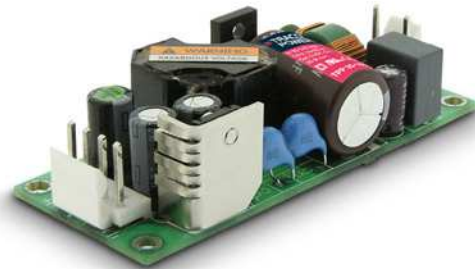

The TPP 30 AC/DC power supplies feature a reinforced double I/O isolation system according to medical safety standards IEC/EN/ES 60601-1 3rd edition for 2 × MOPP approved for an operating altitude of 5000 m. The earth leakage current is below 100 µA what makes the units suitable for BF (body floating) applications. The excellent efficiency of up to 91.5% offers a high power density in the packaging format 1.36" x 3.34". The full load operating temperature range covers -40°C to +63°C while it goes up to 85°C with 50% load derating. The units operate in compliance to the medical EMC emission and immunity levels according to latest standard IEC 60601-1-2 4th edition.

Models				
Order Code	Output Power (max.)	Output Voltage	Output Current (max.)	Efficiency (typ.)
TPP 30-103A-J	20 W	3.3 VDC	6'000 mA	84.0 %
TPP 30-105A-J	30 W	5.0 VDC	6'000 mA	87.0 %
TPP 30-109A-J		9.0 VDC	3'340 mA	88.0 %
TPP 30-112A-J		12 VDC	2'500 mA	90.5 %
TPP 30-115A-J		15 VDC	2'000 mA	90.5 %
TPP 30-124A-J		24 VDC	1'250 mA	89.5 %
TPP 30-136A-J		36 VDC	840 mA	90.0 %
TPP 30-148A-J		48 VDC	630 mA	91.5 %

### Input Specifications

Input voltage range	– AC range (universal input)	85 – 264 VAC (derating of 4%/V below 90 VAC input required)
	– DC range	120 – 370 VDC
Input frequency		47 – 63 Hz
Input current at full load	– at 115 VAC / 230 VAC	0.80 A max. / 0.40 A max.
Input protection		T1.6 A/250 VAC (internal fuse in both line & neutral)
Input inrush current	– at 230 VAC	40 A max.
Zero load power consumption		0.04 W max. (acc. ErP directive)

### Output Specifications

Voltage set accuracy		±1%
Voltage adjustment		±10%
Regulation	– Input variation – Load variation (0 - 100%)	0.2% max. 0.7% max. 0.5% max.
	3.3 & 5 VDC model: other models:	
Minimum load		not required
Temperature coefficient		0.02%/K
Hold-up time	– Vin = 115 VAC	16 ms typ.
Start-up time		1500 ms max.
Rise time		40 ms typ.
Ripple and noise (20Mhz Bandwidth)	- single output model	3.3, 5.0 & 9.0 VDC outputs: 50 mVp-p typ. w. cap. 10µF/20V 1206 X7R MLCC 12, 15, 24 & 36 VDC outputs: 50 mVp-p typ. w. cap. 1µF/50V 1206 X7R MLCC 48 VDC output: 50 mVp-p typ. w. cap. 0.1µF/50V 1206 X7R MLCC
Transiente response	– Peak deviation – Recovery time	3% max. (25% load step change) 500 µs typ.
Overvoltage protection		125 – 140% of nominal Vout
Current limitation		at 140% Iout typ.
Short circuit protection		continuous (automatic recovery), hiccup

### General Specifications

Temperature ranges	– Operating – Storage	–40°C to +85°C with derating –40°C to +85°C
Output power derating	– Temperature – Low input voltage	2.27 %/K above +63°C (up to 85°C max.) 4.0 %/V below 90 VAC
Humidity (non condensing)		5 – 95 % rel. H max.
Altitude during operation		5000 m
Switching frequency (at 230 VAC)		45 kHz typ. (±15 kHz) (pulse width modulation)
Isolation voltage	– Input / Output (60 s)	4000 VAC (2 × MOPP insulation)
Leakage current (at 264 VAC/60Hz)		100 µA max.
Isolation resistance (at 500 VDC)		100 Mohm min.
Reliability	– calculated MTBF at +25°C acc. to MIL-HDBK-217F	3'300'000 h

All specifications valid at nominal input voltage, full load and +25°C after warm-up time unless otherwise stated.

### General Specifications (continued)

EMC emission	<ul style="list-style-type: none"> <li>– Conducted &amp; Radiated input surpression</li> <li>– Harmonic current emissions</li> <li>– Voltage flicker</li> </ul>	EN 55011 limits to IEC 60601-1-2 4th edition EN 55032 class B (internal filter) IEC / EN 61000-3-2, class A IEC / EN 61000-3-3, (class tba.)
EMC immunity	<ul style="list-style-type: none"> <li>– ESD (electrostatic discharge)</li> <li>– Radiated immunity</li> <li>– Fast transient</li> <li>– Surge</li> <li>– Conducted immunity</li> <li>– Magnetic field immunity</li> <li>– Voltage dip and interruptions</li> </ul>	EN 55024, EN 60601-1-2 4th edition EN 61000-4-2, air $\pm 15$ kV, contact $\pm 8$ kV, perf. criteria A EN 61000-4-3, 20 V/m, perf. criteria A EN 61000-4-4, $\pm 2$ kV, perf. criteria A EN 61000-4-5, $\pm 1$ kV perf. criteria A EN 61000-4-6, 20 Vrms, perf. criteria A EN 61000-4-8, 30 A/m, perf. criteria A EN 61000-4-11,
Safety standards and certification	<ul style="list-style-type: none"> <li>– Certification documents</li> </ul>	UL 60950-1, IEC/EN 60950-1, IEC/EN 60601-1 3rd edition, ANSI/AAMI ES60601-1:2005(R)2012 <a href="http://www.tracopower.com/overview/tpp30">www.tracopower.com/overview/tpp30</a>
Shock and vibration		Vibration acc. IEC 60068-2-6 Shock acc. IEC 60068-2-27
Environmental compliance	<ul style="list-style-type: none"> <li>– Reach</li> <li>– RoHS</li> </ul>	<a href="http://www.tracopower.com/products/reach-declaration.pdf">www.tracopower.com/products/reach-declaration.pdf</a> RoHS directive 2011/65/EU
Protection class		class I & II prepared
Connection		pin connector

### Outline Dimensions

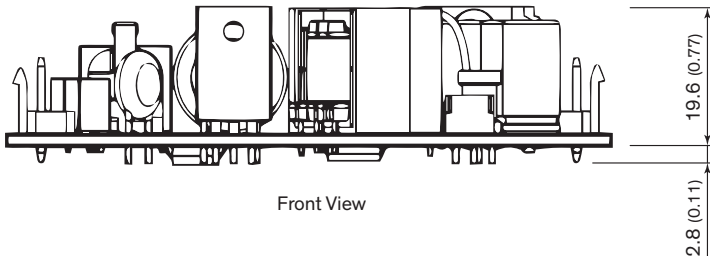

Each one of the 4 screw holes can be used as a PE connection for class I applications

Print thickness: 1.6 mm (0.06 inch)

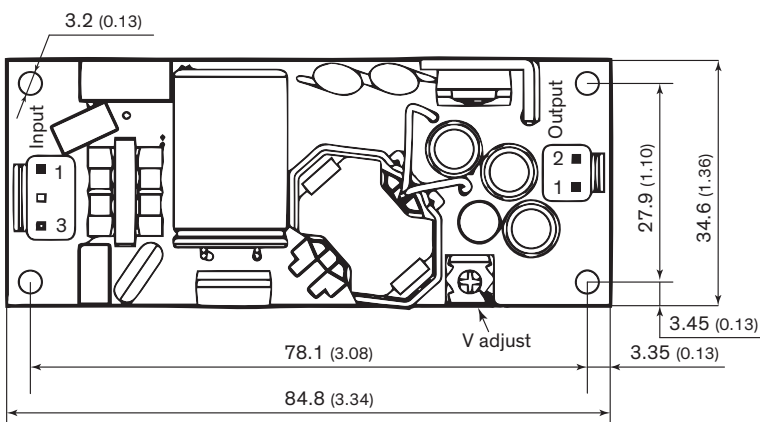

**Weight:** 60.5 g (2.13 oz)

### Pin Connector

Input		Output	
Pin	Single	Pin	Dual
1	Line	1	-Vout
3	Neutral	2	+Vout

**Input:** JST series  
 mates with JST crimp terminal: BVH-21T-P1.1  
 and terminal housing: VHR-3N

**Output:** JST series  
 mates with JST crimp terminal: BVH-21T-P1.1  
 and terminal housing: VHR-2N

Dimension in mm, ( ) = inch  
 Tolerances: x.x  $\pm 0.5$  ( $\pm 0.02$ )  
 x.xx  $\pm 0.25$  ( $\pm 0.01$ )