

MOB-SST | Horizontal toggle clamps

with straight base, stainless steel



MATERIAL

AISI 304 stainless steel.

RIVETS

AISI 304 stainless steel.

HANDLE

Polyurethane, red colour.

STANDARD EXECUTIONS

- **MOB-NX**: with open clamping lever and two folded washers.
- **MOB-PX**: with solid clamping lever and bolt retainer.

CLAMPING BOLTS

To be ordered separately.

FEATURES AND APPLICATIONS

All articulated joints are lubricated with special grease.
Main feature of MOB. toggle clamps is the low closing profile. These tools are designed to avoid that the operator's fingers may be hit by the lever while opening.
During clamping, the lever is controlled to prevent impact on functioning due to side thrust.

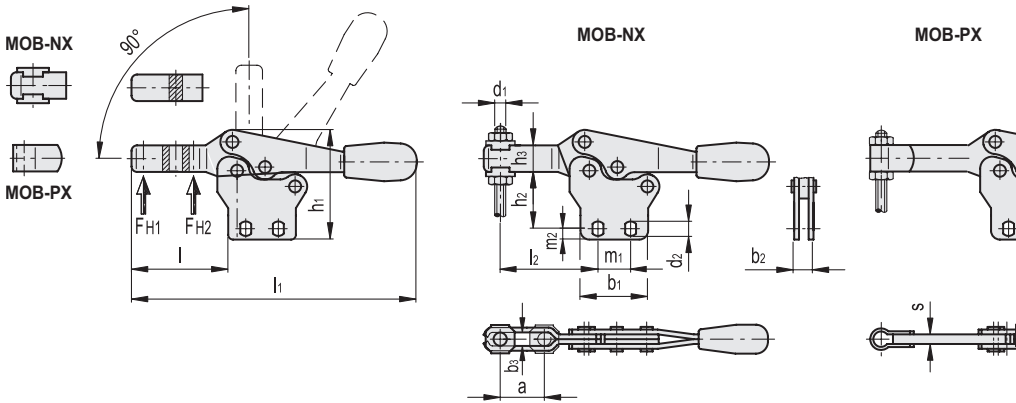
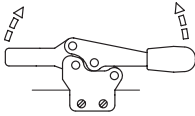

MOB-NX



Code	Description	a	b1	b2	b3	d1	d2	h1	h2	h3	l	l1	l2	m1	m2	FH1 [N]*	FH2 [N]*	⚖️
GG.DS080	MOB.75-NX	20	28	8	5.5	M5	4.5	44.5	24+25.5	11	40	118	40	13.5	4.5	900	1350	88
GG.DS140	MOB.130-NX	32	36	10	6.5	M6	5.5	64	35+38	14	56	170	53	26	7	1000	2000	200
GG.DS275	MOB.230-NX	37	44	12	8.5	M8	6.5	74.5	42+44.5	18	65	195	63.5	26	6.8	1700	3300	330

MOB-PX



Code	Description	b1	b2	d1	d2	h1	h2	h3	l	l1	m1	m2	s	FH1 [N]*	FH2 [N]*	⚖️
GG.DS090	MOB.75-PX	28	8	M5	4.5	44.5	24+25.5	11	40.5	118.5	13.5	4.5	4	900	1350	88
GG.DS150	MOB.130-PX	36	10	M6	5.5	64	35+38	14	57	171	26	7	5	1000	2000	200
GG.DS285	MOB.230-PX	44	12	M8	6.5	74.5	42+44.5	18	67	197	26	6.8	6	1700	3300	340

* Holding force.

