

SDG107

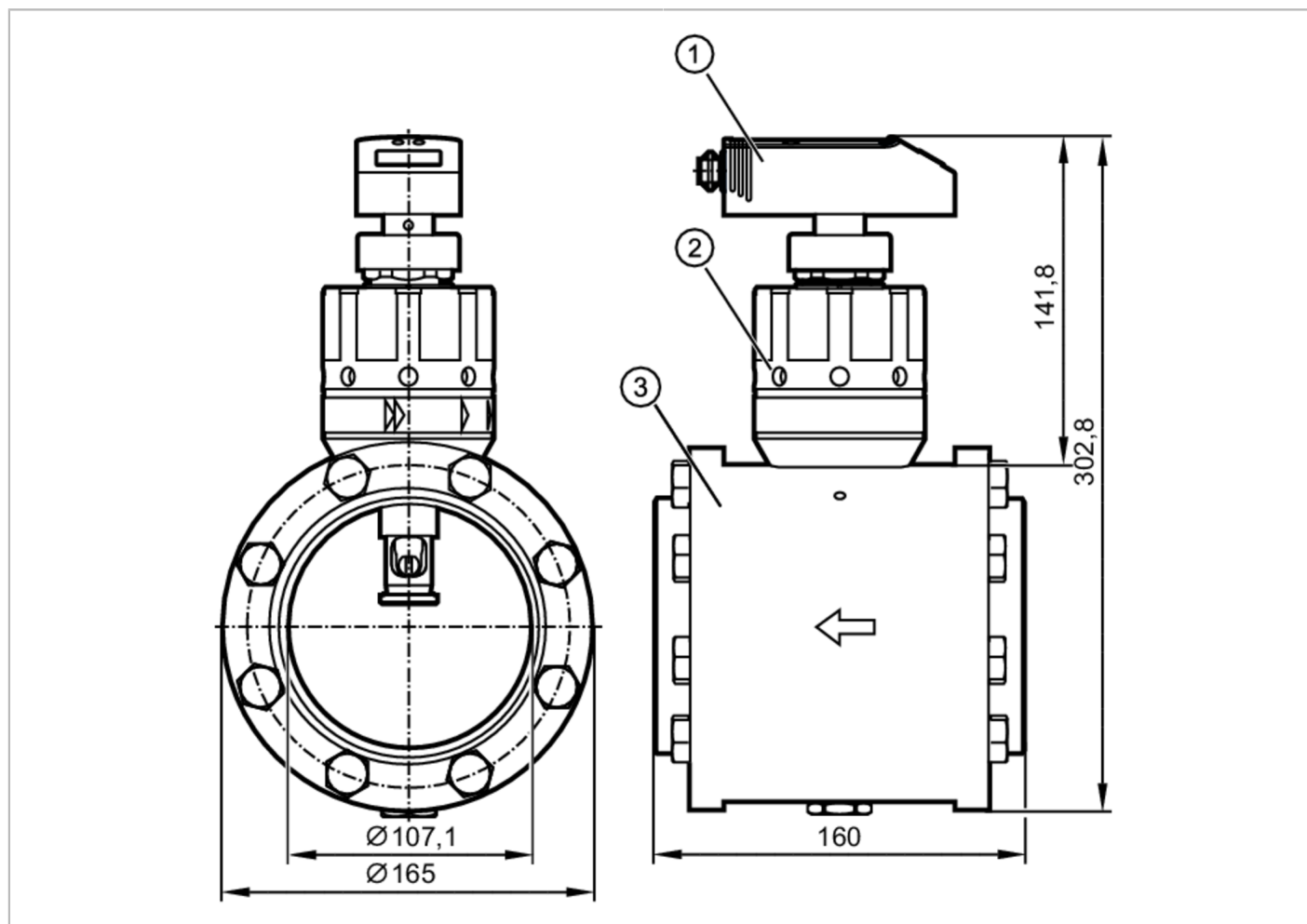

Compressed air meter

SDG4"/METRIS PB DN100 SS LM



Product characteristics	
Number of inputs and outputs	Number of digital outputs: 2; Number of analogue outputs: 1
Measuring range [m ³ /h]	15...4400
Process connection	flange DN100 according to: DIN 2448
Application	
Application	totaliser function
Media	compressed air
Note on media	air quality ISO 8573-1
	class 141
	class 344
Medium temperature [°C]	0...60
Pressure rating [bar]	16
Electrical data	
Operating voltage [V]	19...30 DC
Current consumption [mA]	< 100
Protection class	III
Reverse polarity protection	yes
Power-on delay time [s]	0.5



Compressed air meter

SDG4"/METRIS PB DN100 SS LM

Inputs / outputs		
Number of inputs and outputs	Number of digital outputs: 2; Number of analogue outputs: 1	
Outputs		
Total number of outputs	2	
Output signal	switching signal; analogue signal; pulse signal; (configurable)	
Electrical design	PNP	
Number of digital outputs	2	
Output function	normally open / normally closed; (parameterisable)	
Max. voltage drop switching output DC [V]	2	
Permanent current rating of switching output DC [mA]	250; (per output)	
Number of analogue outputs	1	
Analogue current output [mA]	4...20; (scalable)	
Max. load [Ω]	500	
Pulse output	consumed quantity meter	
Short-circuit protection	yes	
Type of short-circuit protection	pulsed	
Overload protection	yes	
Measuring/setting range		
Measuring range [m ³ /h]	15...4400	
Display range [m ³ /h]	0...5320	
Volumetric flow quantity monitoring		
Pulse value	10 Nm ³	
Pulse length [s]	0,1	
Accuracy / deviations		
Flow monitoring		
Accuracy (in the measuring range)	$\pm (3 \% MW + 0,3 \% MEW) / \pm (6 \% MW + 0,6 \% MEW)$; (class 141 / ; class 344)	
Response times		
Flow monitoring		
Response time [s]	0.1; (dAP = 0)	
Operating conditions		
Ambient temperature [°C]	0...60	
Storage temperature [°C]	-20...85	
Max. relative air humidity [%]	90	
Protection	IP 65	
Tests / approvals		
EMC	EN 61000-4-2 ESD	4 kV CD / 8 kV AD
	EN 61000-4-3 HF radiated	10 V/m
	EN 61000-4-4 Burst	2 kV
	EN 61000-4-6 HF conducted	10 V
Vibration resistance	DIN IEC 68-2-6	5 g (55...2000 Hz)
MTTF [years]		214

SDG107



Compressed air meter

SDG4"/METRIS PB DN100 SS LM

Mechanical data	
Weight [g]	16003
Materials	PBT-GF20; PC; PC; stainless steel (1.4301 / 304); FKM; pipe section: stainless steel (1.4301 / 304)
Materials (wetted parts)	stainless steel (1.4401 / 316); stainless steel (1.4301 / 304); ceramics glass passivated; PEEK; polyester; FKM; aluminium anodised; stainless steel (1.4301 / 304)
Process connection	flange DN100 according to: DIN 2448
Remarks	
Remarks	MW = measured value MEW = Final value of the measuring range Measuring, display and setting ranges refer to the standard volume flow according to DIN ISO 2533. For information about installation and operation please see the operating instructions.
Pack quantity	1 pcs.

Electrical connection

Connector: 1 x M12



Connection

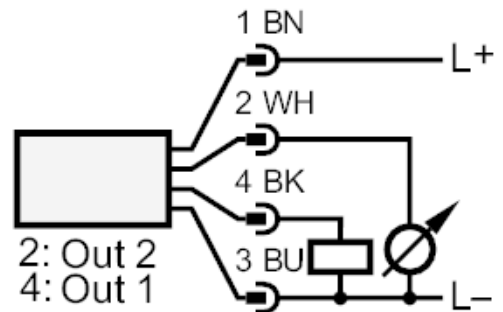
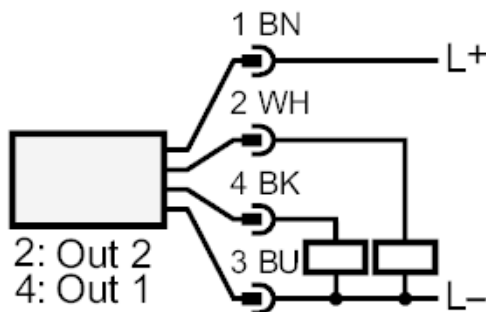

- OUT1: switching output
Pulse output quantity meter
- OUT2: switching output
input counter reset
analogue output