

DO NOT SCALE DRAWING

REVISIONS

ZONE	REV.	DESCRIPTION	DATE	APPROVED
	A	DRAWN	08-08-2013	

Body

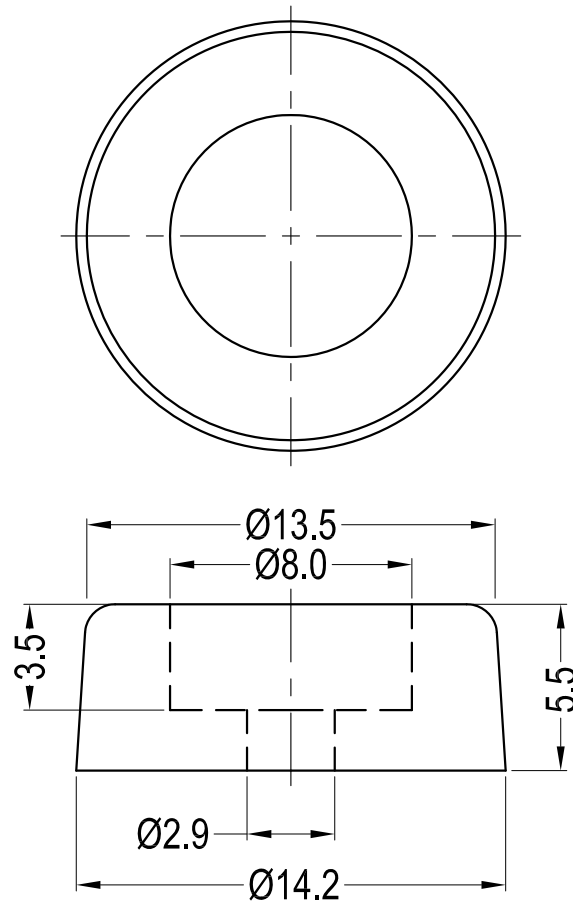

Assembly

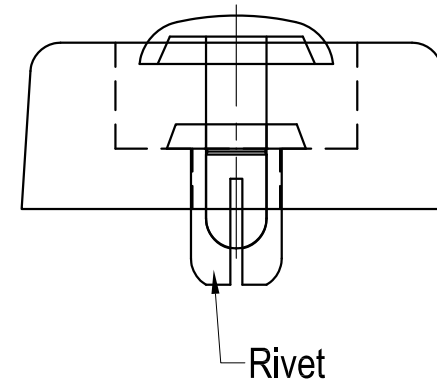

Rivet

Part No.	Panel Thickness
TRFF-003-P3x5.5B	0.8-1.8
TRFF-003-P3x6.5B	1.8-2.8

Notes:

1. Material: TPR UL94 HB (Body)  
PA6 UL94 V2 (Rivet)
2. RoHS Compliant;
3. Hole:  $\text{Ø}3.1-3.2\text{mm}$ .



DESIGN RIGHT. TR FASTENINGS LTD, 2003  
UNDER NO CIRCUMSTANCES MUST THIS  
DRAWING BE COPIED OR DISCLOSED,  
WITHOUT FIRST OBTAINING WRITTEN  
AUTHORITY.

UNLESS OTHERWISE SPECIFIED:  
DIMENSIONS ARE IN MILLIMETERS.  
SURFACE FINISH:  
TOLERANCES:  
 $L \leq 4 = \pm 0.1$   $4 < L \leq 15 = \pm 0.2$   
 $15 < L \leq 50 = \pm 0.3$   $50 < L \leq 100 = \pm 0.4$

NAME	DATE
DRAWN: MARTIN ELLIOTT	08/08/2013
CHK'D:	
APPV'D:	

MATERIAL

SEE NOTES

HEAT TREATMENT

N/A

FINISH

Black

TITLE

SOFT FAST FOOT

CUSTOMER PART NO.

DWG NO.

TRFF-003

A3

PROJECTION



SHEET 1 OF 1