

# 4/3-way servo solenoid directional control valves with electrical position feedback (Lvdt DC/DC) (ruggedized design)

**RE 29084/01.09**

Replaces: 01.05

## Type 4WRL10...25

Sizes (NG) 10, 16, 25

Unit series 3X

Maximum working pressure P, A, B 350 bar

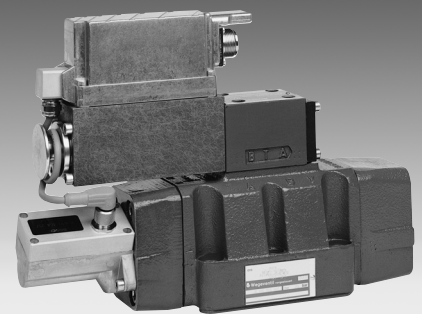
Nominal flow rate 55...370 l/min ( $\Delta p$  10 bar)

## List of contents

Contents	Page
Features	1
Ordering data	2
Symbols, accessories	3
Function, sectional diagram	4
Control oil supply	5
Technical data	6 and 7
Valve with external trigger electronics	8 and 9
Characteristics curves	10 and 11
Unit dimensions	12 to 14



## Features

- Pilot operated 4/3-way servo solenoid directional control valves NG10 to NG25
- Pilot valve NG6, with control piston and sleeve in servo quality and sturdy design, actuated on one side, 4/4 fail-safe position when switched off
- Position transducer (Lvdt DC/DC) with metal cap
- Main stage in servo quality with position feedback
- Flow characteristic
  - M = Progressive with fine metering notch
  - P = Non-linear curve
  - L = Linear
- For subplate attachment, mounting hole configuration  
NG10 to ISO 4401-05-05-0-05,  
NG16 to ISO 4401-07-07-0-05 and  
NG25 to ISO 4401-08-08-0-05
- Subplates as per Technical Data Sheet, NG10 RE 45055,  
NG16 RE 45057 and NG25 RE 45059 (order separately)
- Plug-in connectors to DIN 43563-AM6,  
see Technical Data Sheet RE 08008 (order separately)
- External trigger electronics (order separately)
  - Electric amplifier for standard curves “M” and “L”
  - Electric amplifier for non-linear curve “P”



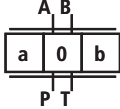

For information regarding the available spare parts see:  
[www.boschrexroth.com/spc](http://www.boschrexroth.com/spc)

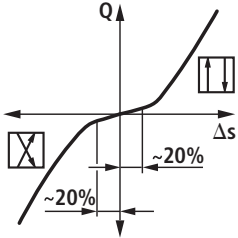
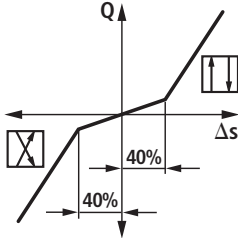
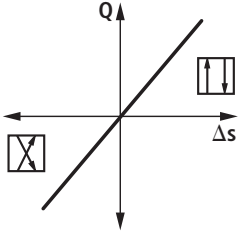

## Symbols

	M: Progressive with fine metering	P: Non-linear, linear (40%)	L: Linear
			

## Accessories, not included in delivery

Fastening bolts 	NG10	4 x ISO 4762-M6 x 40-10.9-N67F821 70	<b>2 910 151 209</b>
	NG16	2 x ISO 4762-M6 x 45-10.9-N67F821 70	<b>2 910 151 211</b>
		4 x ISO 4762-M10 x 50-10.9-N67F821 70	<b>2 910 151 301</b>
	NG25	6 x ISO 4762-M12 x 60-10.9-N67F821 70	<b>2 910 151 354</b>
 		VT-VVRA1-527-20/V0/2STV, see RE 30045	<b>0 811 405 063</b>
		VT-VVRA1-527-20/V0/K40-AGC-2STV, see RE 30043	<b>0 811 405 068</b>
 6P+PE (Pg16)		Plug-in connector not included in delivery, also see RE 08008	<b>1 834 482 024</b>

## Testing and service equipment

- Test box type VT-PE-TB2, see RE 30064
- Test adapter type VT-PA-3, see RE 30070

## Function, sectional diagram

### Construction

The valve consists of two main assemblies:

- Pilot valve (1) with control spool and sleeve, return springs, control solenoid and inductive position transducer
- Main stage (2) with centering springs and position feedback

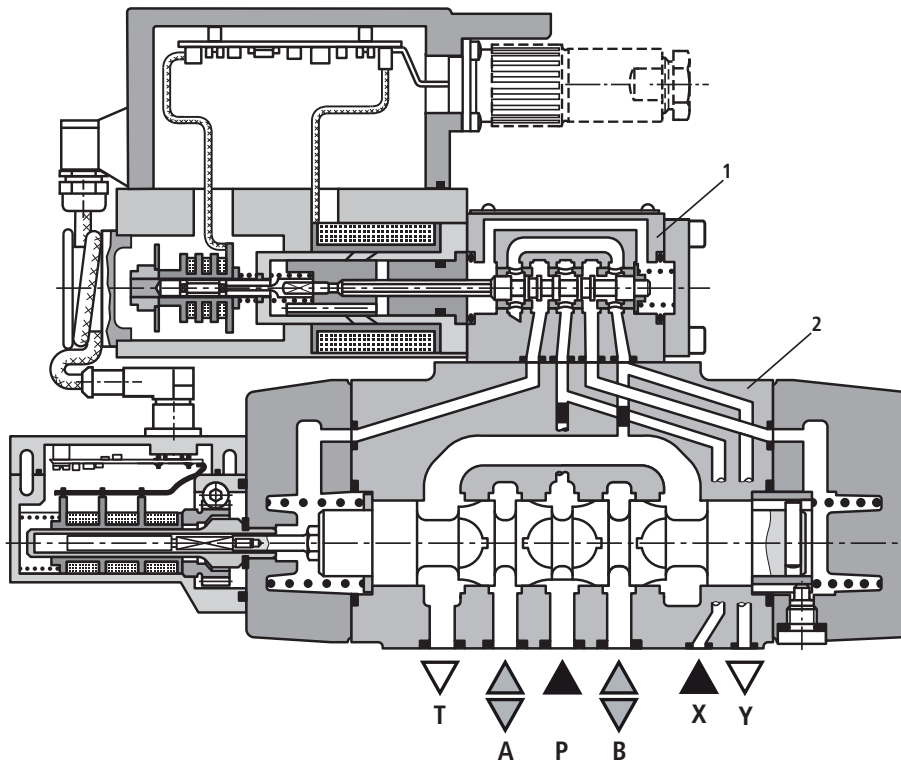

### Functional description

When the control solenoid is not actuated, the control spool is held by springs in the fail-safe position, and the main stage spool remains in spring-centered mid position at 1...6% of the stroke in the direction P-B/A-T.

In the on-board electronics, the pre-defined setpoint is compared with the actual value for the position of the main stage control spool. In the event of an error signal, the control solenoid is actuated, and the pilot spool is moved as the magnetic force changes. The flow released through the control cross-sections causes the main control spool to move. The stroke/control cross-section of the main control spool is controlled proportionately to the setpoint. If the input setpoint is 0 V, the electronics move the main stage control spool to mid position.

The control oil is conveyed to the pilot valve either internally via port P or externally via port X. The oil returns to the tank internally via port T or externally via port Y.

### Power failure

In the event of a power failure or an open circuit, the on-board electronics cut off the electricity to the control solenoid and the pilot spool moves to the "fail-safe" position, relieving the control oil chambers of the main stage. The main stage control spool is held by springs in mid position.

## Control oil supply

The pilot valve can be supplied both via ports X and Y (externally) and via the main flow channels P and T.

NG10, 25

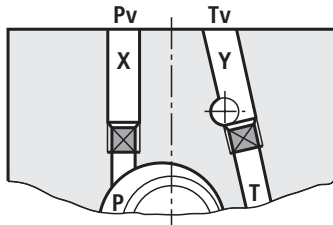

NG16

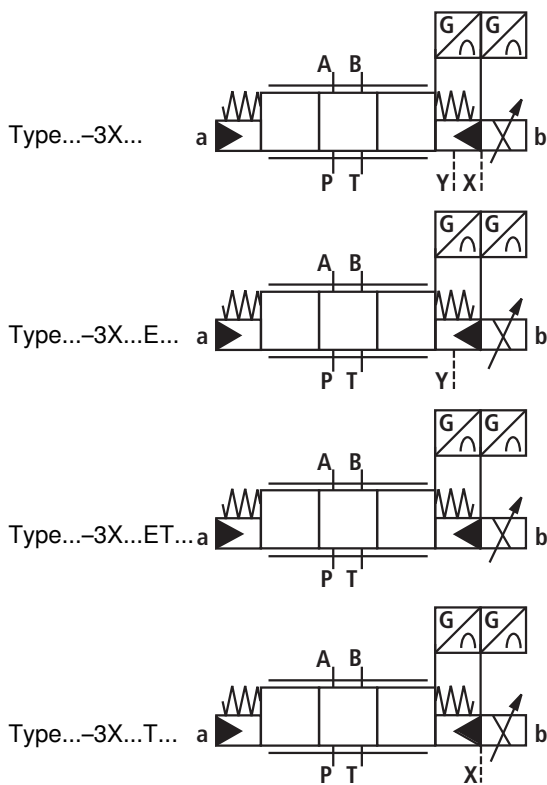
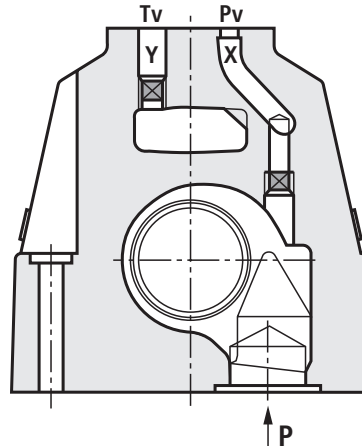

Symbol in detail  
(external control oil inlet and outlet)

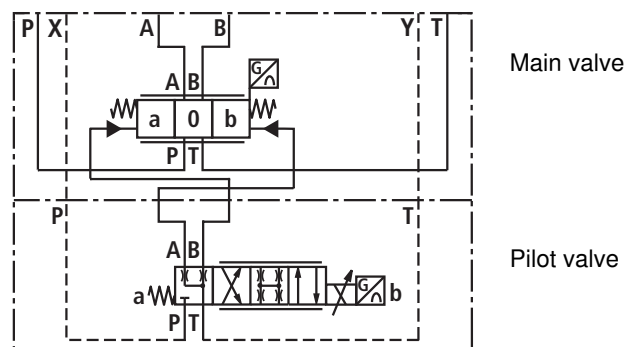

<b>No designation =</b>	"x" = external	"y" = external
<b>E =</b>	"x" = internal	"y" = external
<b>ET =</b>	"x" = internal	"y" = internal
<b>T =</b>	"x" = external	"y" = internal

### Important

Hydraulic symbols are largely derived from the symbols of the switching valves. 4/3-way servo solenoid directional control valves (pilot operated) do not have a closed mid position when switched off! They only perform their function in an active, closed control loop, even if the pilot valve features a fail-safe 4th position. See technical data for details on "switch-off behavior".

## Technical data

### General

Construction	Spool type valve, pilot operated			
Actuation	Servo solenoid directional control valve NG6, with position controller for pilot valve and main stage, external electric amplifier			
Type of mounting	Subplate, mounting hole configuration NG10...25 to ISO 4401-...			
Installation position	Optional			
Ambient temperature range	°C	-20...+60		
Weight	kg	<b>NG10</b> 8.6	<b>NG16</b> 10.3	<b>NG25</b> 18.3
Vibration resistance, test condition	Max. 40 g, shaken in 3 dimensions (24 h)			

### Hydraulic (measured with HLP 46, $\vartheta_{oil} = 40 \text{ °C} \pm 5 \text{ °C}$ )

Pressure fluid	Hydraulic oil to DIN 51524...535, other fluids after prior consultation									
Viscosity range	recommended	mm <sup>2</sup> /s	20...100							
	max. permitted	mm <sup>2</sup> /s	10...800							
Pressure fluid temperature range	°C	-20...+70								
Maximum permissible degree of contamination of pressure fluid Purity class to ISO 4406 (c)	Class 18/16/13 <sup>1)</sup>									
Flow direction	See symbol									
Nominal flow at $\Delta p = 5 \text{ bar per notch}^4)$	l/min	<b>NG10</b>				<b>NG16</b>			<b>NG25</b>	
		40 <sup>3)</sup>	55 <sup>1)</sup>	70 <sup>2)</sup>	85 <sup>3)</sup>	90 <sup>2)</sup>	120 <sup>3)</sup>	150 <sup>2)</sup>	200 <sup>3)</sup>	300 <sup>2)</sup>
Max. working pressure Ports P, A, B	bar	350								
Max. pressure Ports T, X, Y	bar	250								
Min. control oil pressure in "pilot stage"	bar	10								
$Q_{max}$	l/min	170			450			900		
$Q_N$ pilot valve	l/min	4			12			24		
Leakage of pilot valve at 100 bar	cm <sup>3</sup> /min	< 180			< 300			< 500		
Leakage of main stage at 100 bar	cm <sup>3</sup> /min	< 400	< 600	< 1000			< 1000			

### Static/Dynamic

Hysteresis	%	< 0.1 scarcely measurable								
Manufacturing tolerance for $Q_{max}$	%	≤ 10								
Response time for signal change (at X = 100 bar)	0...100 %	25			40			45		
	0...10 %	15			18			20		
Response time for signal change (at X = 10 bar)	0...100 %	85			90			150		
	0...10 %	50			40			80		
Switch-off behavior	After electrical switch-off: pilot valve in "fail-safe" Main stage moves to spring-centered "mid position": 1...6% P-B/A-T									
Thermal drift	Zero point displacement < 1 % at $\Delta T = 40 \text{ °C}$									
Zero adjustment	Adjustable ±5% via valve amplifier									

<sup>1)</sup> The purity classes stated for the components must be complied with in hydraulic systems. Effective filtration prevents problems and also extends the service life of components. For a selection of filters, see Technical Data Sheets RE 50070, RE 50076 and RE 50081.

<sup>2)</sup> Characteristic curve: P (non-linear).

<sup>3)</sup> Characteristic curve: M or L

<sup>4)</sup> Flow rate at a different  $\Delta p$   $Q_x = Q_{nom} \cdot \sqrt{\frac{\Delta p_x}{5}}$

## Technical data

---

### Electrical

Cyclic duration factor	%	100 ED
Power supply		24 V DC <sub>nom</sub> (external electric amplifier)
Degree of protection		IP 65 to DIN 40050, plug-in connector 1 834 482 024 correctly fitted
Solenoid and position transducer connector		To DIN 43563-AM6 (plug-in connector 1 834 482 024) Pg16 For pin assignment, see block diagram on pages 8 and 9
Max. solenoid current	A	2.7
Coil resistance $R_{20}$	$\Omega$	2.5
Max. power consumption at 100% load and operating temperature	VA	40
Position transducer DC/DC technology		Supply: +15 V/35 mA -15 V/25 mA Signal: 0...±10 V ( $R_L \geq 10 \text{ k}\Omega$ )

All characteristics only in connection with valve amplifier 0 811 405 063

### Important

Pilot operated 4/3-way servo solenoid directional control valves only perform their function in an active closed control loop and do not have a "fail-safe" position when switched off. For this reason, many applications require the use of "external check valves", which must be taken into account during the On/Off switching sequence.

# Valve with external trigger electronics (standard linear curve: M, L)

## Block diagram/pin assignment

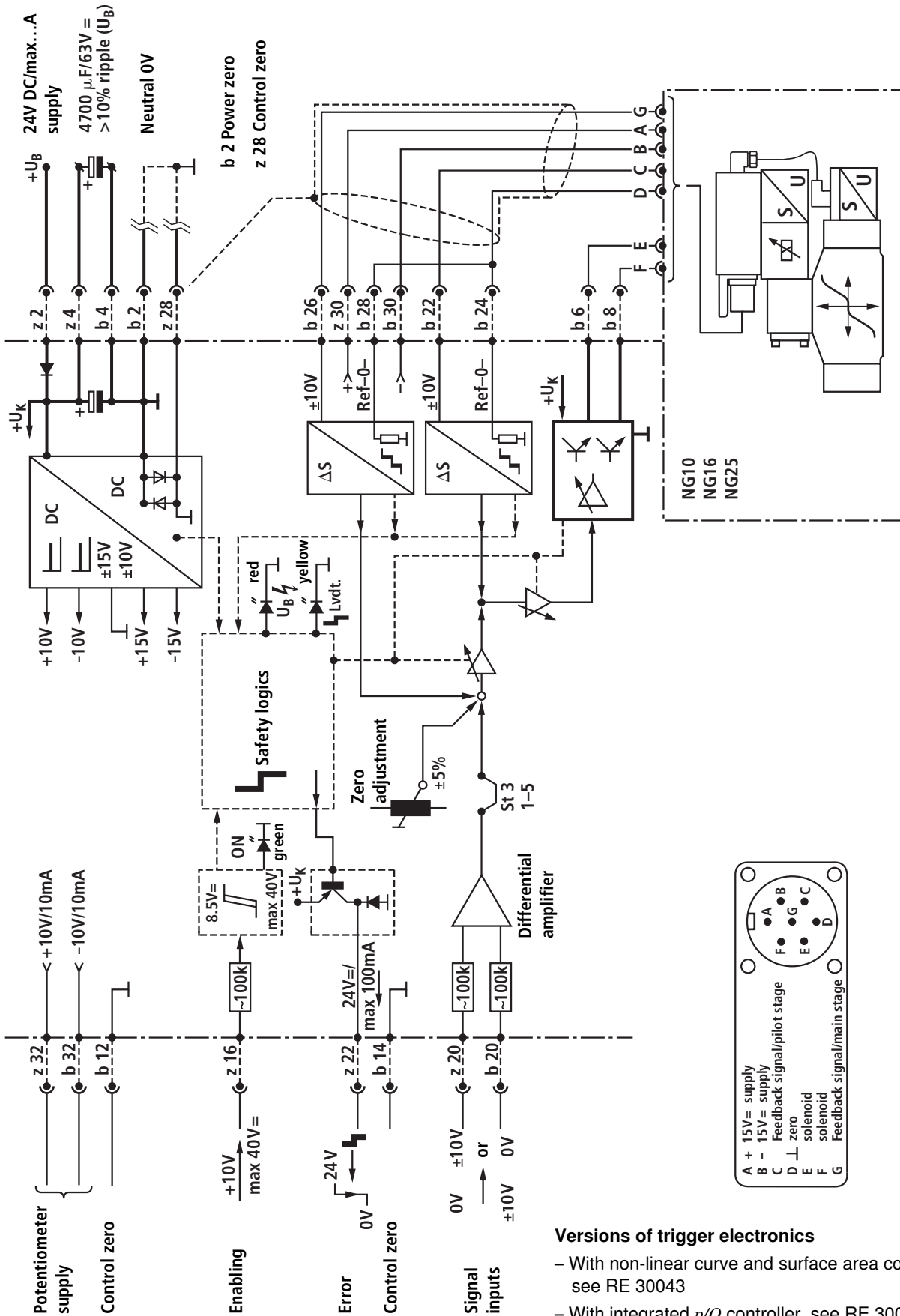

### Versions of trigger electronics

- With non-linear curve and surface area compensation, see RE 30043
- With integrated p/Q controller, see RE 30058



# Valve with external trigger electronics (non-linear curve: P)

## Block diagram/pin assignment

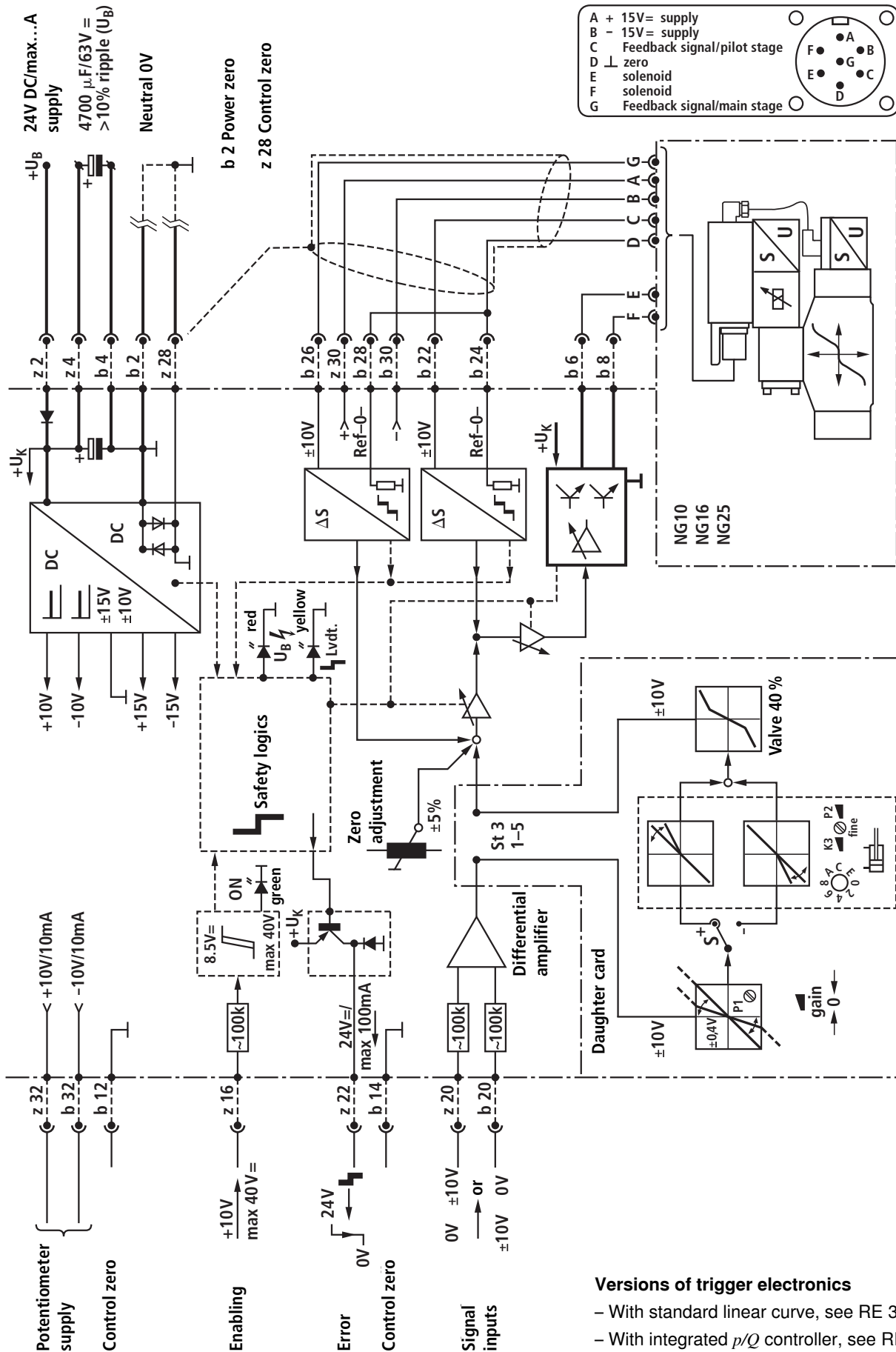

- Versions of trigger electronics**
- With standard linear curve, see RE 30045
  - With integrated p/Q controller, see RE 30058

### Characteristic curves (measured with HLP 46, $\vartheta_{oil} = 40 \text{ }^\circ\text{C} \pm 5 \text{ }^\circ\text{C}$ )

Flow rate – signal function  $Q = f(U_E)$

Flow characteristic M

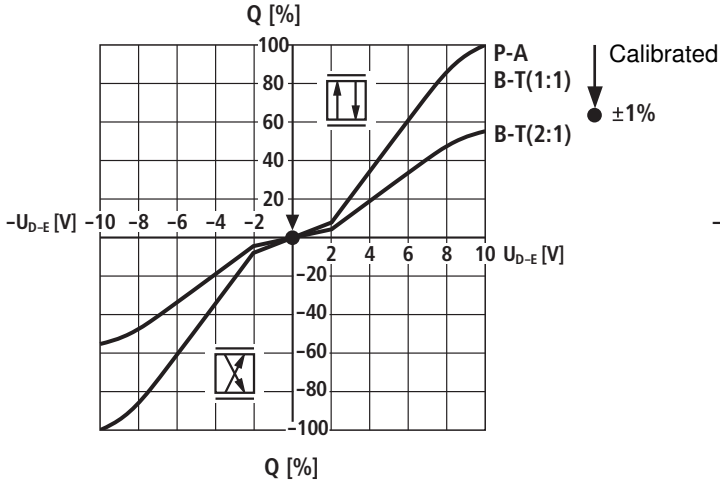

Flow characteristic P

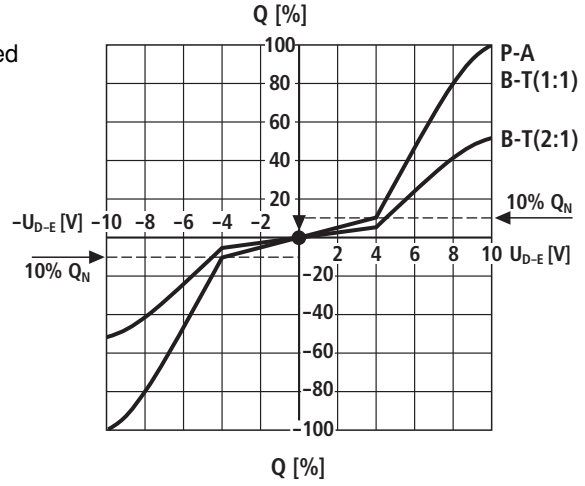

Flow characteristic L

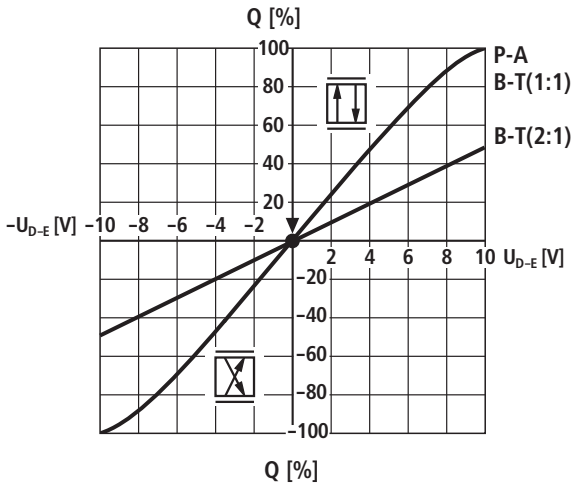

### Pressure gain

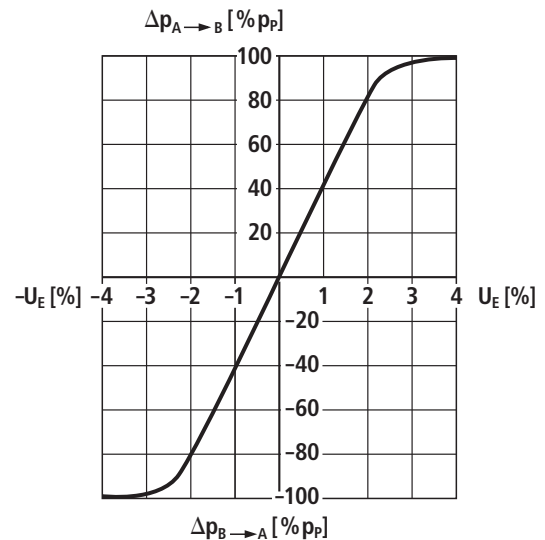
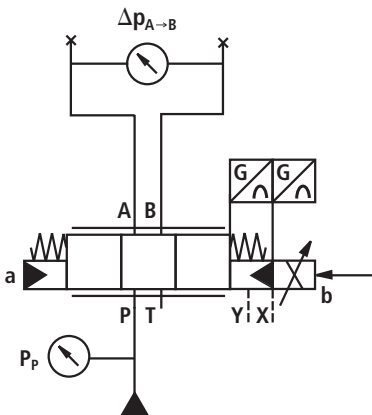

**Characteristic curves** (measured with HLP 46,  $\vartheta_{oil} = 40 \text{ }^\circ\text{C} \pm 5 \text{ }^\circ\text{C}$ )

**Bode diagram**

**NG10**

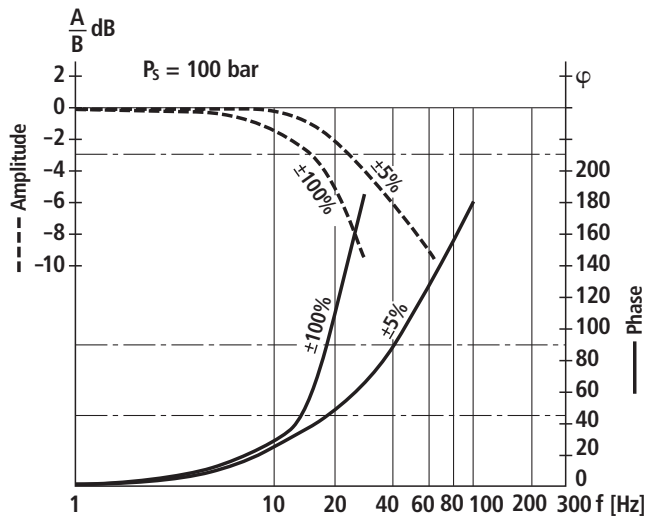

**NG16**

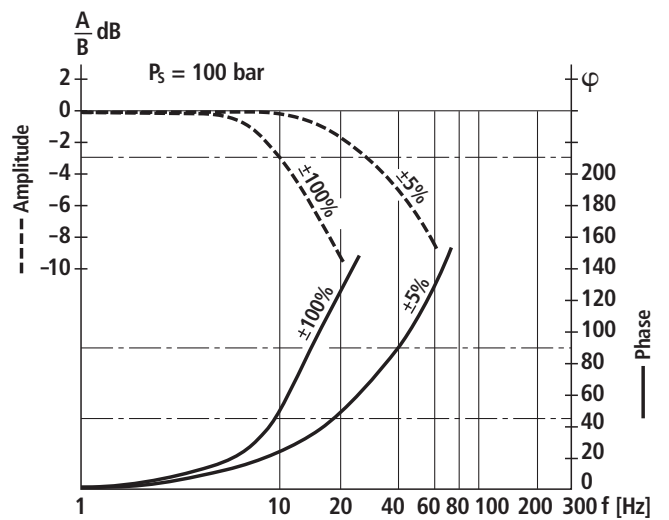

**NG25**

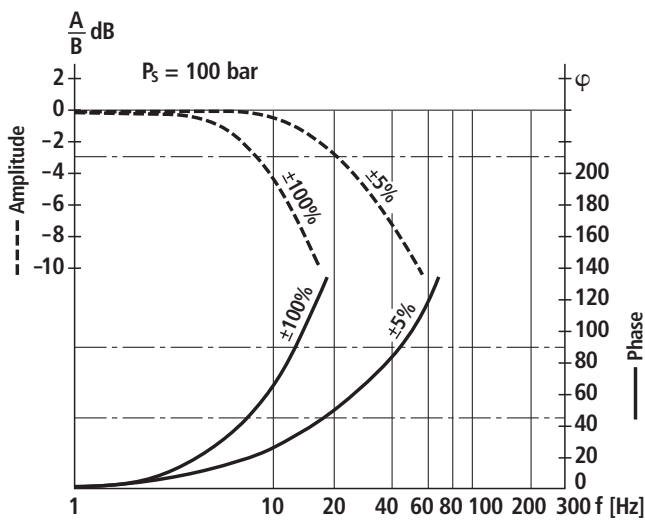

**Unit dimensions NG10 (nominal dimensions in mm)**

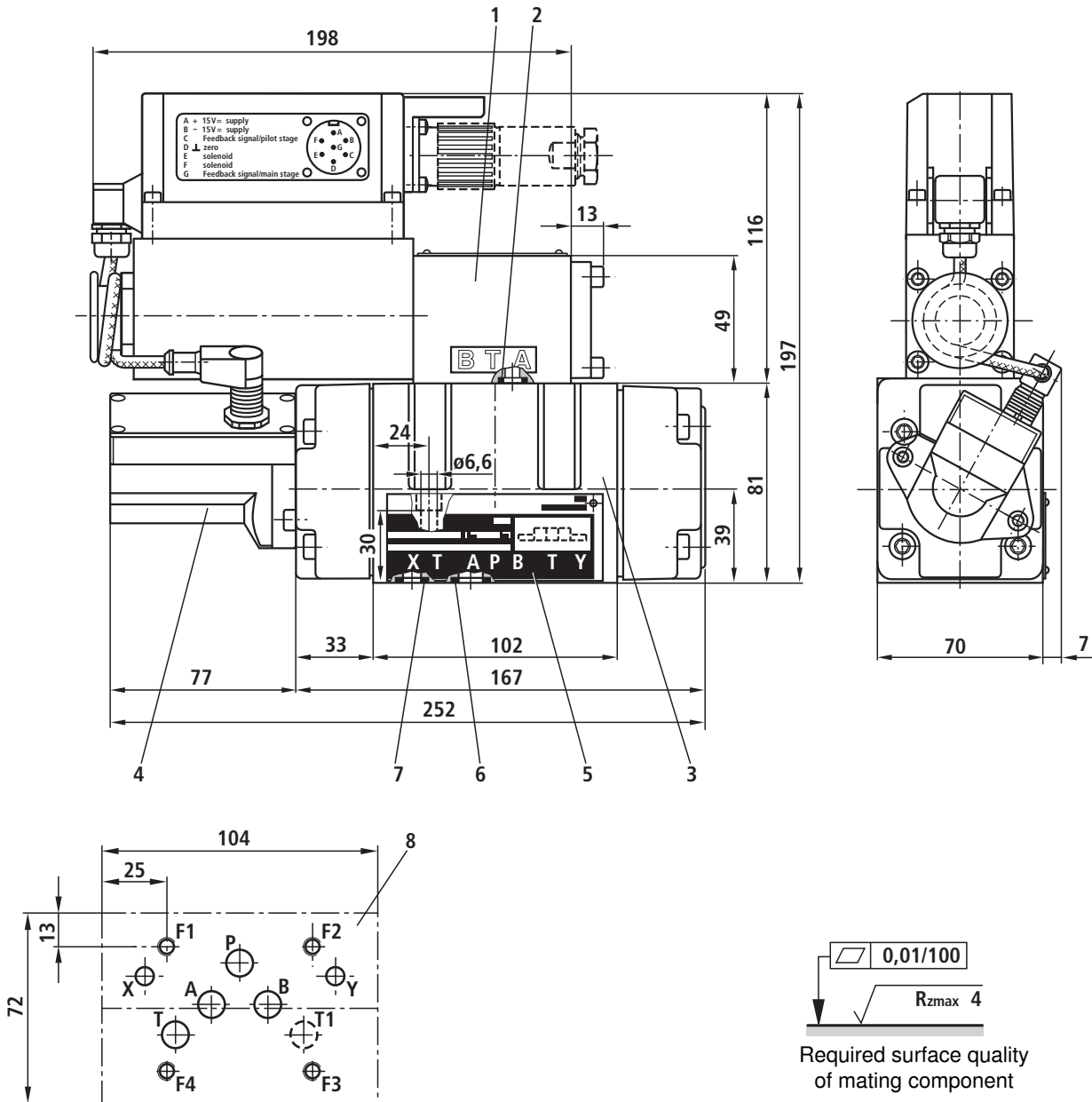

- 1 Pilot valve
- 2 O-ring 9.25 x 1.78 (ports P, A, B, T)
- 3 Main valve
- 4 Inductive position transducer (main valve)
- 5 Nameplate
- 6 O-ring 12 x 2 (ports P, A, B, T, T1)
- 7 O-ring 10 x 2 (ports X, Y)

- 8 Machined valve contact surface, mounting hole configuration according to ISO 4401-05-05-0-05  
 Deviates from standard:  
 Ports P, A, B, T, T1  $\varnothing 10.5$  mm  
 Minimum thread depth: Ferrous metal 1.5 x  $\varnothing$   
 Non-ferrous 2 x  $\varnothing$

**Subplates**, see Technical Data Sheet RE 45055

**Valve fastening bolts** (order separately)

The following valve fastening bolts are recommended:

- 4 cheese-head bolts ISO 4762-M6x40-10.9-N67F821 70**  
 (galvanized in accordance with Bosch standard N67F821 70)  
 Tightening torque  $M_A = 11+3$  Nm  
 Material no. **2910151209**

## Unit dimensions NG16 (nominal dimensions in mm)

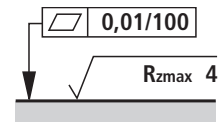
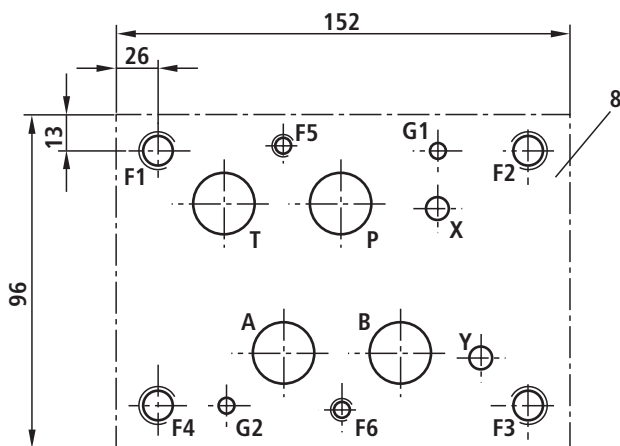
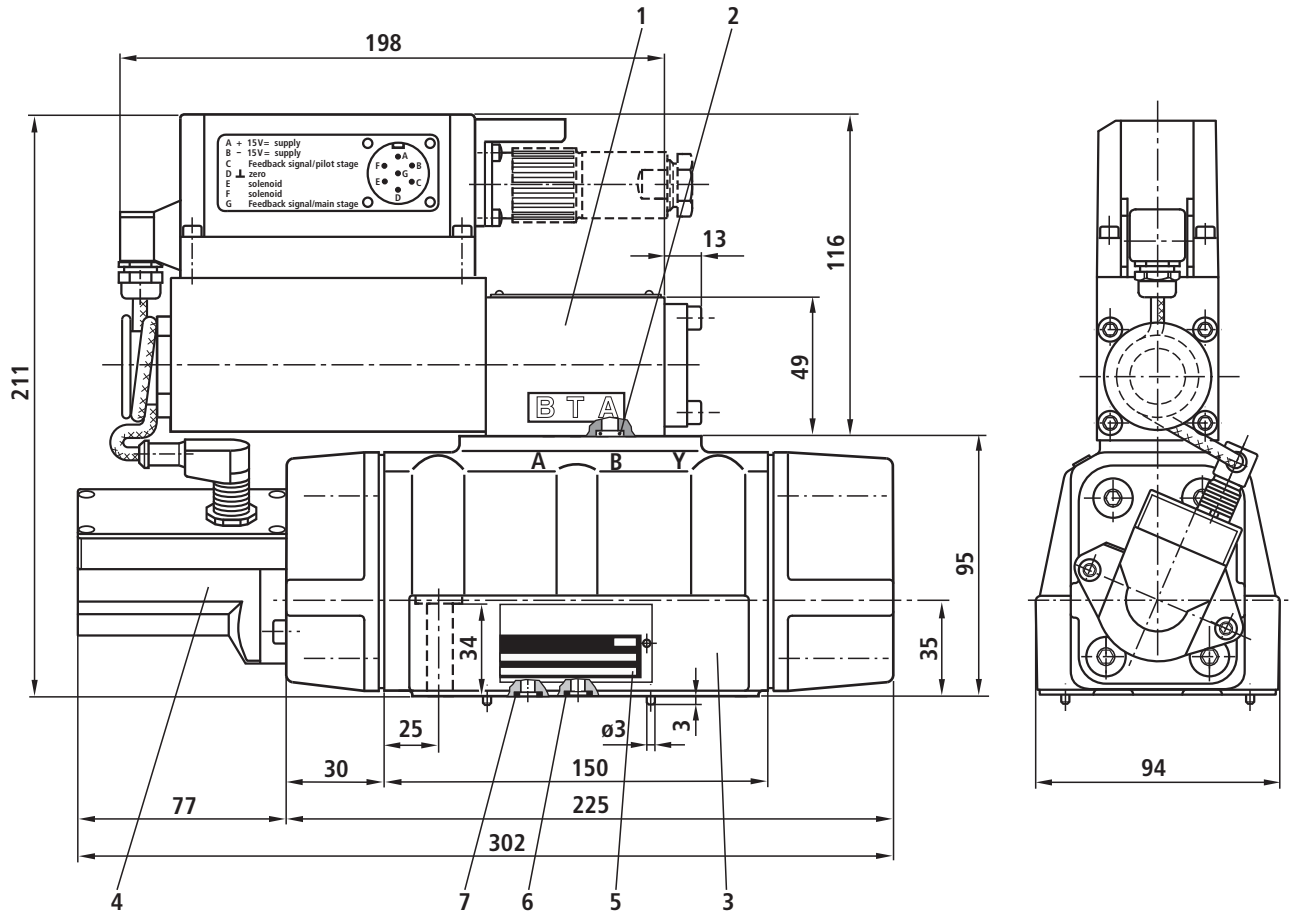

Required surface quality of mating component

- 1 Pilot valve
- 2 O-ring 9.25 x 1.78 (ports P, A, B, T)
- 3 Main valve
- 4 Inductive position transducer (main valve)
- 5 Nameplate
- 6 O-ring 23 x 2,5 (ports P, A, B, T)
- 7 O-ring 9 x 2 (ports X, Y)

**8** Machined valve contact surface, mounting hole configuration according to ISO 4401-07-07-05

Deviates from standard:

Ports P, A, B, T  $\varnothing$  20 mm

Minimum thread depth: Ferrous metal 1.5 x  $\varnothing$

Non-ferrous 2 x  $\varnothing$

**Subplates**, see Technical Data Sheet RE 45057

**Valve fastening bolts** (order separately)

The following valve fastening bolts are recommended:

**2 cheese-head bolts ISO 4762-M6x45-10.9-N67F821 70**

(galvanized in accordance with Bosch standard N67F821 70)

Tightening torque  $M_A = 11+3$  Nm

Material no. **2910151211**

**4 cheese-head bolts ISO 4762-M10x50-10.9-N67F821 70**

(galvanized in accordance with Bosch standard N67F821 70)

Tightening torque  $M_A = 50+10$  Nm

Material no. **2910151301**

**Unit dimensions NG25 (nominal dimensions in mm)**

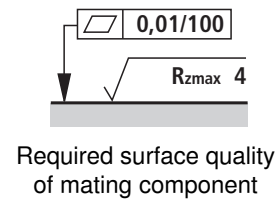
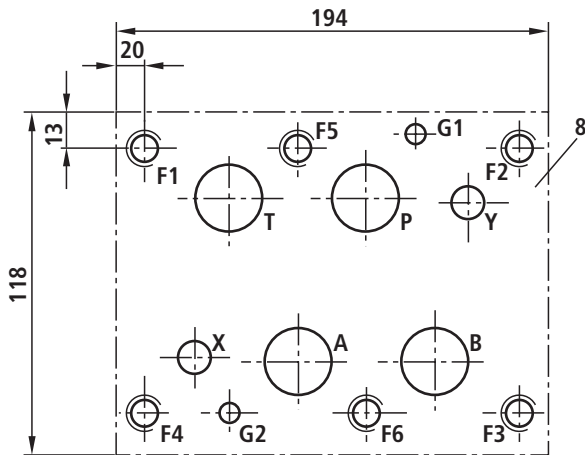
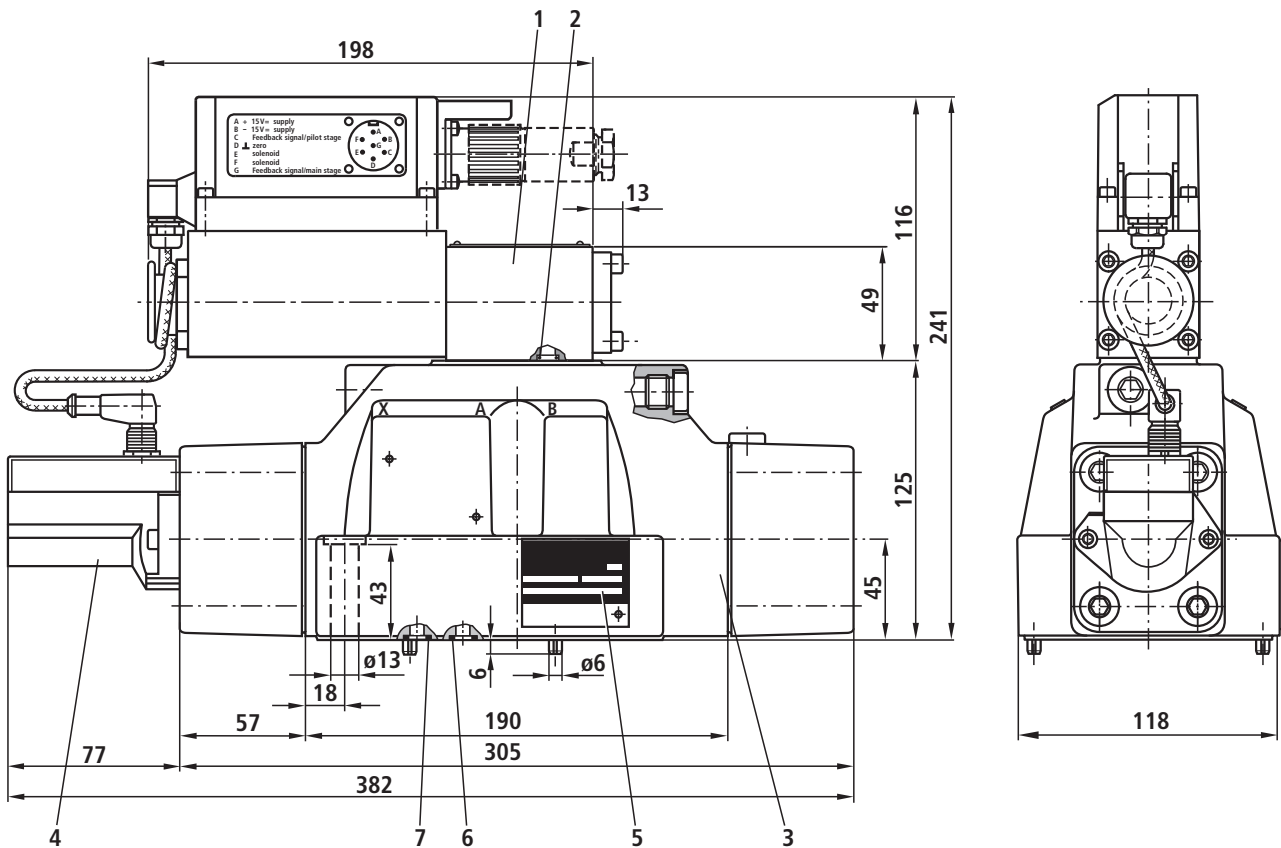

- 1 Pilot valve
- 2 O-ring 9.25 x 1.78 (ports P, A, B, T)
- 3 Main valve
- 4 Inductive position transducer (main valve)
- 5 Nameplate
- 6 O-ring 28 x 3 (ports P, A, B, T)
- 7 O-ring 15 x 2,5 (ports X, Y)

**8** Machined valve contact surface, mounting hole configuration according to ISO 4401-08-08-0-05

Deviates from standard:

NG25: Ports P, A, B, T  $\varnothing$  25 mm

Minimum thread depth: Ferrous metal 1.5 x  $\varnothing$

Non-ferrous 2 x  $\varnothing$

**Subplates**, see Technical Data Sheet RE 45059

**Valve fastening bolts** (order separately)

The following valve fastening bolts are recommended:

**6 cheese-head bolts ISO 4762-M12x60-10.9-N67F821 70**

(galvanized in accordance with Bosch standard N67F821 70)

Tightening torque  $M_A = 90+30$  Nm

Material no. **2910151354**

**Notes**

---

## Notes

---