

TEMPERATURE MONITORING RELAY FOR IO-LINK
THERMOCOUPLER J,K,T,E,N,R,S,B 2 LIMIT VALUES
-99 DEGR. C TO 1800 DEGR. C 3X1W, WIDTH 45 MM
SPRING-LOADED TERMINAL

General technical data:

Type of voltage		DC
Control supply voltage 1 for DC		
• Rated value	V	24
• Initial rated value	V	18
• Final rated value	V	30
Product function		
• Fault storage		Yes
• External reset		Yes
Number of measuring circuits		1
Number of NC contacts for auxiliary contacts		0
Number of NO contacts for auxiliary contacts		0
Number of CO contacts for auxiliary contacts		3
Measurable temperature		
• initial value	°C	-99
• Full-scale value	°C	1 800
Equipment marking acc. to DIN EN 61346-2		K
Equipment marking acc. to DIN 40719 extended according to IEC 204-2 acc. to IEC 750		K
Ambient temperature during operation	°C	-25 ... +60

Communication/ Protocol:

Type of voltage supply via input/output link master		Yes
IO-Link transfer rate		COM2 (38,4 kBaud)
Protocol is supported IO-Link protocol		Yes
Amount of data		

• of the address area of the outputs with cyclical transfer total	byte	2
• of the address area of the inputs with cyclical transfer total	byte	4
Point-to-point cycle time between master and IO-Link device minimum	ms	10

Mechanical data:

Type of electrical connection		spring-loaded terminals
<ul style="list-style-type: none"> • for auxiliary and control current circuit • Plug-in socket 		Yes
Design of the sensor connectable		type J, K, T, E, N, R, S, B (thermocouple)
Width	mm	45
Height	mm	108
Depth	mm	91

Certificates/ approvals:

General Product Approval	other	
Manufacturer declaration	Environmental Confirmations	Declaration of Conformity
		

Further information

Information- and Downloadcenter (Catalogs, Brochures,...)

<http://www.siemens.com/industrial-controls/catalogs>

Industry Mall (Online ordering system)

<http://www.siemens.com/industrymall>

Cax online generator

<http://support.automation.siemens.com/WW/CAXorder/default.aspx?lang=en&mlfb=3RS15402HB80>

Service&Support (Manuals, Certificates, Characteristics, FAQs,...)

<http://support.automation.siemens.com/WW/view/en/3RS15402HB80/all>

Image database (product images, 2D dimension drawings, 3D models, device circuit diagrams, EPLAN macros, ...)

<http://www.automation.siemens.com/bilddb/index.aspx?attID9=3RS15402HB80&lang=en>

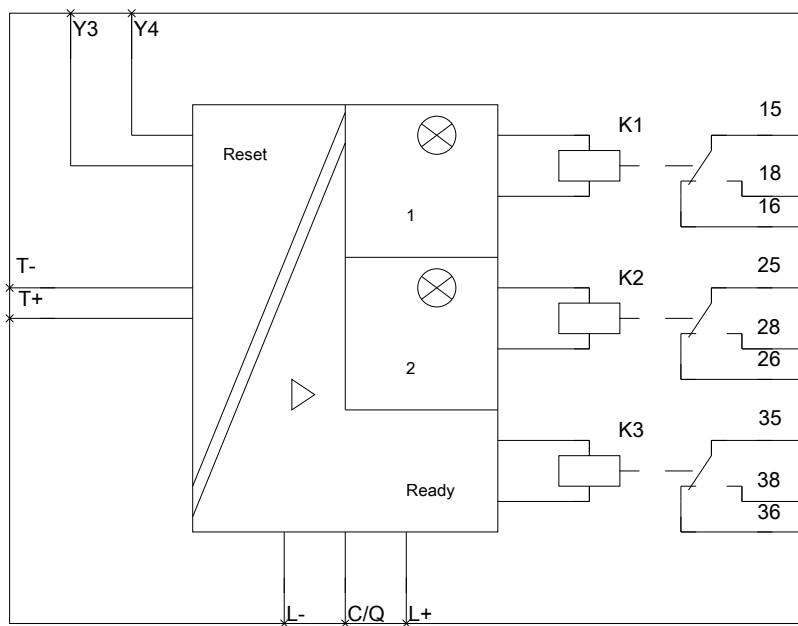
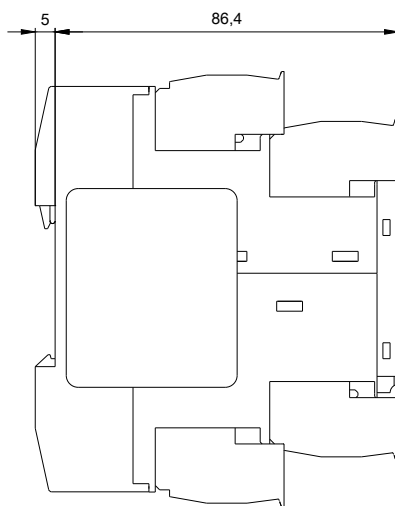
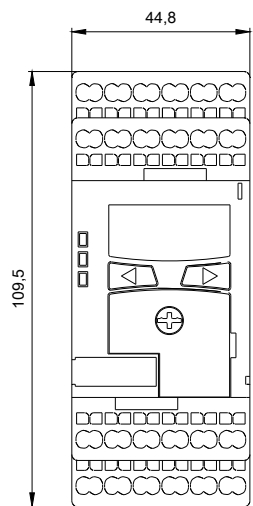

last modified:

09.03.2015