

BUSBAR SYSTEM, ACCESSORY FOR 40 AND 60 MM SYSTEM ONLY FOR 5MM BUSBAR THICKNESS

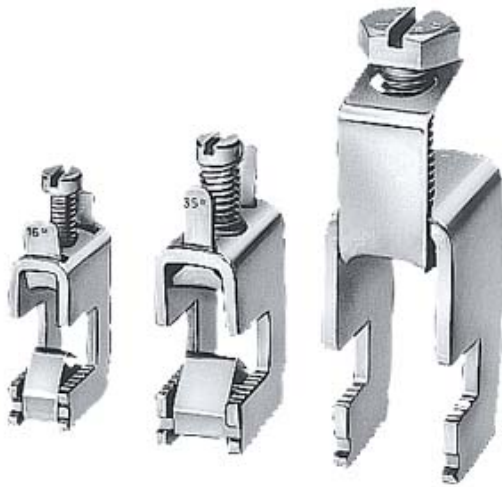

## Model

product brand name

SENTRON

### General Product Approval

Declaration of  
Conformity

Test  
Certificates



CSA



GOST



UR



EG-Konf.

[Special Test Certificate](#)

### Shipping Approval

other



GL



PRS



RINA

[other](#)

## Further information

Information- and Downloadcenter (Catalogs, Brochures,...)

<http://www.siemens.com/lowvoltage/catalogs>

Industry Mall (Online ordering system)

<https://eb.automation.siemens.com/mall/en/WW/Catalog/Product/8US19212AB00>

Service&Support (Manuals, Certificates, Characteristics, FAQs,...)

<http://support.automation.siemens.com/WW/view/en/8US19212AB00/all>

Image database (product images, 2D dimension drawings, 3D models, device circuit diagrams, ...)

[http://www.automation.siemens.com/bilddb/cax\\_en.aspx?mlfb=8US19212AB00](http://www.automation.siemens.com/bilddb/cax_en.aspx?mlfb=8US19212AB00)

Cx-Online-Generator

<http://www.siemens.com/cax>

**Tender specifications**

<http://ausschreibungstexte.siemens.com/tiplv>

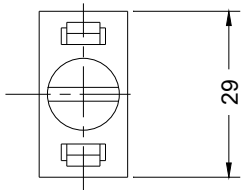
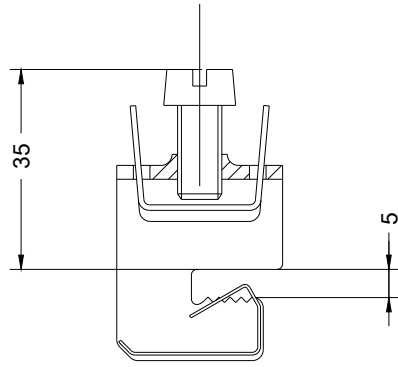
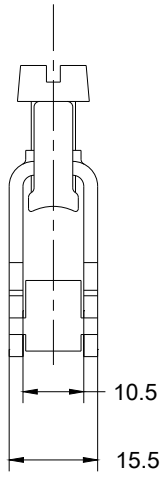

**last modified:**

11.03.2015