

MALE-FEMALE RIGHT ANGLE ADAPTER

R141.770.000

Series : BNC

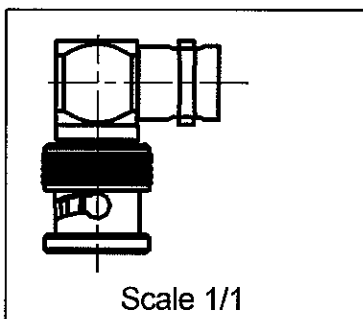
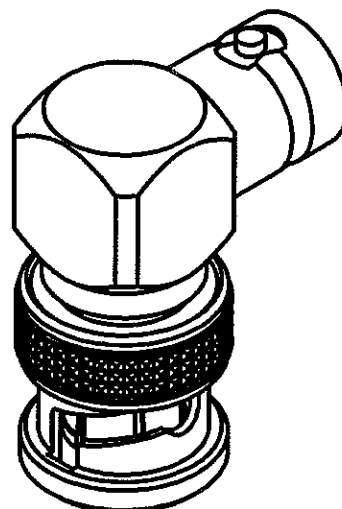
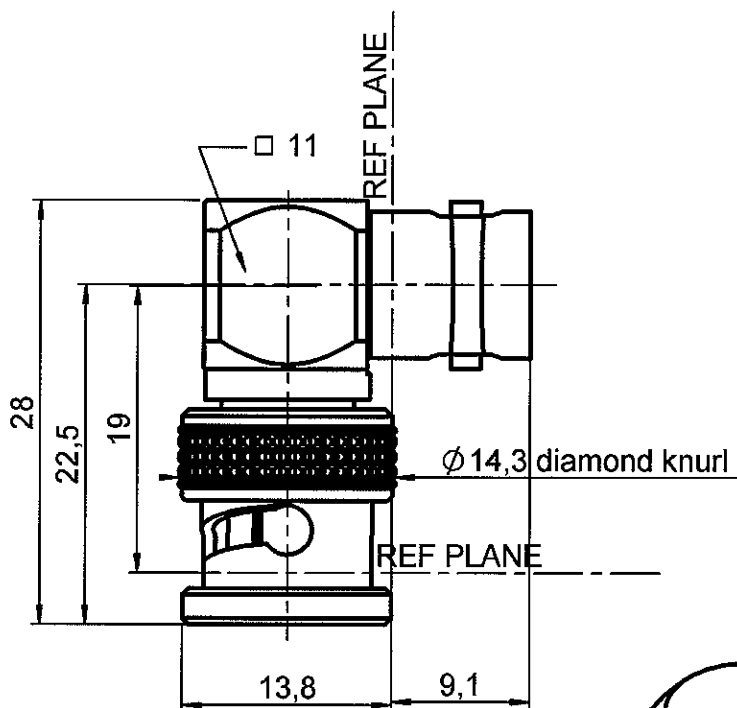

All dimensions are in mm.

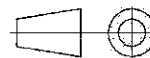

COMPONENTS	MATERIALS	PLATING (µm)
BODY	BRASS	NICKEL 2
CENTER CONTACT	BERYLLIUM COPPER, BRASS	GOLD 0.5 OVER NICKEL 2
OUTER CONTACT	-	-
INSULATOR	PTFE	-
GASKET	SILICONE RUBBER	-
OTHERS PARTS	BRASS	NICKEL 2
-	-	-
-	-	-

Issue : 0525 J

In the effort to improve our products, we reserve the right to make changes judged to be necessary.



MALE-FEMALE RIGHT ANGLE ADAPTER

R141.770.000

Series : BNC

PACKAGING

Standard	Unit	Other
100	'W' option	Contact us

SPECIFICATION

ELECTRICAL CHARACTERISTICS

Impedance		50 Ω
Frequency		0-4 GHz
VSWR	1.35 +	0.000 x F(GHz) Maxi
Insertion loss		0.175 √F(GHz) dB Maxi
RF leakage	-(57 - F(GHz)) dB Maxi
Voltage rating		500 Veff Maxi
Dielectric withstanding voltage		1500 Veff mini
Insulation resistance		5000 MΩ mini

ENVIRONMENTAL

Operating temperature	-65/+165 °C
Hermetic seal	NA Atm.cm3/s
Panel leakage	NA

OTHER CHARACTERISTICS

Assembly instruction NA

Others :
-

MECHANICAL CHARACTERISTICS

Center contact retention	
Axial force – Mating end	18 N mini
Axial force – Opposite end	18 N mini
Torque	2.8 N.cm mini
Recommended torque	
Mating	NA N.cm
Panel nut	NA N.cm
Mating life	500 Cycles mini
Weight	15.000 g

Issue : 0525 J

In the effort to improve our products, we reserve the right to make changes judged to be necessary.

