

Datasheet - TVS 410SK-11/11U



Safety switch for hinged guards / Hinge safety switch / TVS 410 / TESF



- Metal enclosure
- Good resistance to oil and petroleum spirit
- For left or right hinged doors
- 141 mm x 115 mm x 21,5 mm
- Simple mounting, suitable for all conventional profile systems (30 ... 60 mm)
- with fixed switching angle

(Minor differences between the printed image and the original product may exist!)

Ordering details

Product type description	TVS 410SK-11/11U
Article number	1182905
EAN code	4030661318417

Approval

Approval



Classification

Standards	EN ISO 13849-1
B _{10d} Opener (NC)	20.000.000
Mission time	20 Years
notice	$MTTF_d = \frac{B_{10d}}{0,1 \times n_{op}}$ $n_{op} = \frac{d_{op} \times h_{op} \times 3600 \text{ s/h}}{t_{zyklus}}$

Global Properties

Product name	TVS 410
Standards	EN 60947-5-1, BG-GS-ET-15
Compliance with the Directives (Y/N)	Yes
Materials	
- Material of the housings	zinc die-cast
- Material of the contacts	Silver-nickel alloy 10
Enclosure color	Black

Weight 640 g

Mechanical data

Design of electrical connection	Screw connection
Cable section	
- Min. Cable section	0,5 mm ²
- Max. Cable section	1 mm ²
Mechanical life	> 1.000.000 operations
Switching frequency	1200 /h
Opening angle	180°
Positive break angle	5°
Adjustable switching angle (Y/N)	Yes
Alignment aid (Y/N)	No
Mounting inside (Y/N)	No
Mounting outside (Y/N)	No
notice	All indications about the cable section are including the conductor ferrules.

Ambient conditions

Ambient temperature	
- Min. environmental temperature	- 25°C
- Max. environmental temperature	+ 65°C
Protection class	IP65

Electrical data

Design of control element	Normally open contact (NO), Opener (NC)
Switching principle	Creep circuit element
Number of auxiliary contacts	2 piece
Number of safety contacts	2 piece
Rated impulse withstand voltage U _{imp}	2.5 kV
Rated insulation voltage U _i	250 V
Thermal test current I _{the}	2.5 A
Utilisation category	AC-15: 230 V / 4 A, DC-13: 24 V / 1 A
Max. fuse rating	2 A gG D-fuse

ATEX

Explosion protection categories for gases	None
Explosion protected category for dusts	None

Dimensions

Dimensions of the sensor	
- Width of sensor	141 mm
- Height of sensor	115 mm
- Length of sensor	21.5 mm

notice

Closed guard device = 0° in contact switch travel diagrams.
The factory-set switching angle is 3°.

The positive break angle is 5°.

Until the limit of the mechanical life has been reached the angle can increase up to 8° under normal wear-out conditions.

Included in delivery

Adjusting tool is included in delivery

Diagram

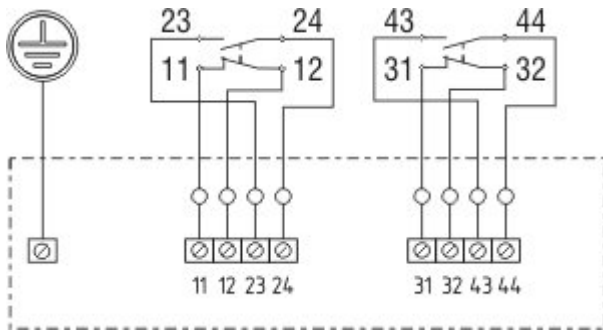

Note Diagram

- positive break NC contact
- active
- no active
- Normally-open contact
- Normally-closed contact

Switch travel diagram

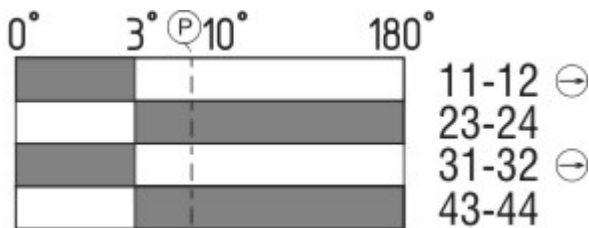

Notes Switch travel diagram

- Contact closed
- Contact open
- Setting range
- Break point
- Positive opening sequence/- angle
- VS** adjustable range of NO contact
- VÖ** adjustable range of NC contact
- N** after travel

Ordering code

TVS 410 (1)-(2)(3)(4)

(1)

- SK** Screw connection
- CC** Spring pulley connection
- ST1** Connector M12 bottom
- ST2** Connector M12 above
- ST4** Connector M16 bottom

ST5 Connector M16 above

(2)

11/11 2 Opener (NC) / 2 Normally open contact (NO) (*Caution! The versions with connector may only be used in PELV circuits to EN 60204-1. Only for ST1, ST2*)

11/01 2 Opener (NC) / 1 Normally open contact (NO) (*Plug-in connection, only for ST1, ST2*)

(3)

U adjustable switching angle

I Mounting inside (with fixed switching angle 3°)

A Mounting outside (with fixed switching angle 3°)

(4)

without None Alignment aid

N with Alignment aid

Documents

Operating instructions and Declaration of conformity (it) 1 MB, 10.12.2010

http://127.0.0.1/Bilddata/Drehbar/Pdf/tvs410/bedien/it/mrl_tvs410_it.pdf

Operating instructions and Declaration of conformity (es) 1 MB, 10.12.2010

http://127.0.0.1/Bilddata/Drehbar/Pdf/tvs410/bedien/es/mrl_tvs410_es.pdf

Operating instructions and Declaration of conformity (jp) 1 MB, 10.12.2010

http://127.0.0.1/Bilddata/Drehbar/Pdf/tvs410/bedien/jp/mrl_tvs410_jp.pdf

Operating instructions and Declaration of conformity (en) 1 MB, 06.12.2010

http://127.0.0.1/Bilddata/Drehbar/Pdf/tvs410/bedien/en/mrl_tvs410_en.pdf

Operating instructions and Declaration of conformity (de) 1 MB, 07.12.2010

http://127.0.0.1/Bilddata/Drehbar/Pdf/tvs410/bedien/de/mrl_tvs410_de.pdf

Operating instructions and Declaration of conformity (nl) 947 kB, 29.09.2010

http://127.0.0.1/Bilddata/Drehbar/Pdf/tvs410/bedien/nl/mrl_tvs410_nl.pdf

Operating instructions and Declaration of conformity (fr) 1 MB, 10.12.2010

http://127.0.0.1/Bilddata/Drehbar/Pdf/tvs410/bedien/fr/mrl_tvs410_fr.pdf

BG-test certificate (de) 416 kB, 11.01.2011

http://127.0.0.1/Bilddata/Drehbar/Pdf/tvs410/baumuste/z_tvsp03.pdf

BG-test certificate (en) 406 kB, 11.01.2011

http://127.0.0.1/Bilddata/Drehbar/Pdf/tvs410/baumuste/z_tvsp04.pdf

Images

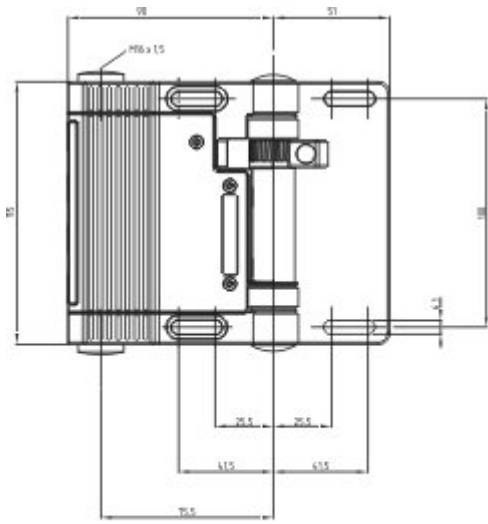

Dimensional drawing (basic component)

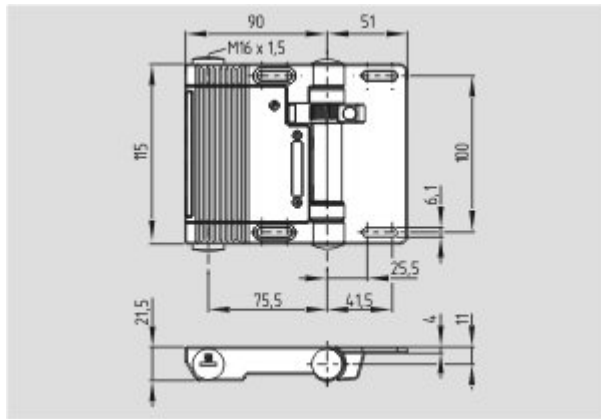

Dimensional drawing (basic component)