

DATA SHEET

GAS DISCHARGE TUBES TELEPHONE INTERFACE

B32 series

RoHS compliant & free



Product specification— February 20, 2024 V.1



Gas Discharge Tube (GDT) Data Sheet

Features

- High insulation resistance
- Low capacitance ($\leq 0.5\text{pF}$)
- 500A 8/20 μs maximum surge current capacity in accordance with IEC61000-4-5
- 4KV 10/700 μs maximum surge rating in accordance with ITU-TK.21
- Surface mounted gas arrester
- Micro-Gap Design
- Size 3216(1206)
- Storage and operating temperature: $-40^{\circ}\text{C} \sim +85^{\circ}\text{C}$
- Meets MSL level 1, per J-STD-020
- Safety certification: UL



Applications

- Repeaters, Modems
- Telephone Interface, Line cards
- Data communication equipment
- Line test equipment

Part Number Code

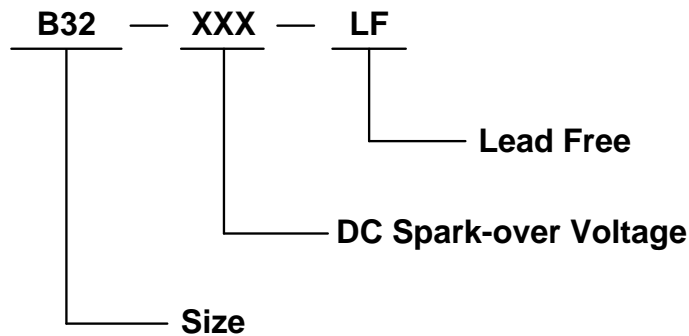

Dimensions

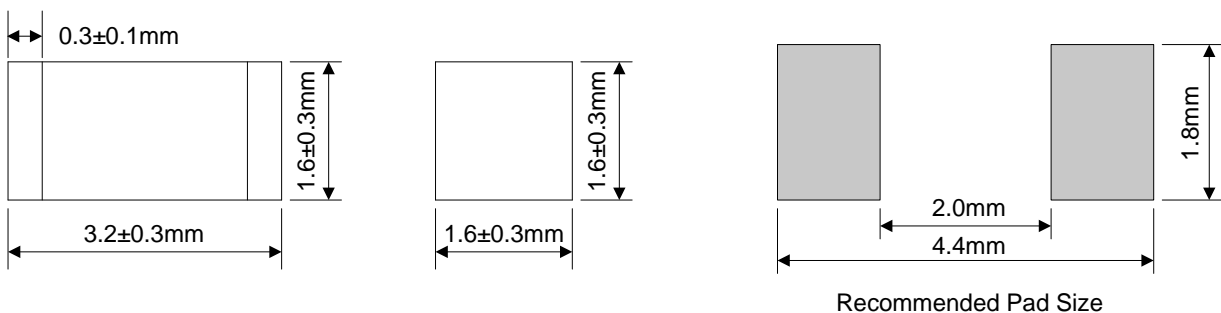

Electrical Characteristics

Part Number	DC Spark-over Voltage	Maximum Impulse Spark-over Voltage	Minimum Insulation Resistance		Maximum Capacitance	Nominal Impulse Discharge Current	Impulse Withstanding Voltage Capacity	Device Marking Code
	100V/s	1000V/ μ s	Test Voltage	(G Ω)	(1MHz)	8/20 μ s 10 Times	10/700 μ s 10 Times	
	(V)	(V)	DC(V)		(pF)	(A)	(KV)	
B32-150-LF	150 \pm 30%	750	50	1	0.5	500	4	None
B32-200-LF	200 \pm 30%	900	100	1	0.5	500	4	None
B32-230-LF	230 \pm 30%	950	100	1	0.5	500	4	None
B32-300-LF	300 \pm 30%	1000	100	1	0.5	500	4	None
B32-350-LF	350 \pm 30%	1100	100	1	0.5	500	4	None
B32-400-LF	400 \pm 30%	1100	100	1	0.5	500	4	None
B32-420-LF	420 \pm 30%	1200	100	1	0.5	500	4	None
B32-470-LF	470 \pm 30%	1200	100	1	0.5	500	4	None

Electrical Ratings

Items	Test Condition/Description	Requirement
DC Spark-over Voltage	The voltage is measured with voltage ramp $dv/dt=100V/s$.	To meet the specified value
Maximum Impulse Spark-over Voltage	The maximum impulse spark-over voltage is measured with voltage ramp $dv/dt=1000V/\mu s$.	
Insulation Resistance	The resistance of gas tube shall be measured between two electrodes.	
Capacitance	The capacitance of gas tube shall be measured between two electrodes. Test frequency: 1MHz	
Impulse Discharge Current	Maximum 8/20 μs surge current that can be applied between two electrodes, 5 positive and 5 negative surges, with 3 minutes interval time.	
Impulse Withstanding Voltage	The maximum 10/700 μs surge that can be applied to the Gas Tube, 5 positive and 5 negative surges, with 1 minute interval time.	

Reliability

Items	Test conditions / Methods	Standard
Cold Resistance	Measurement after -40 °C /1000 HRS & normal temperature/2 HRS.	Features are conformed to rated spec.
Heat Resistance	Measurement after 125 °C /1000 HRS & normal temperature/2 HRS.	
Humidity Resistance	Measurement after humidity 90~95°C(45°C) /1000 HRS & normal temperature/2 HRS.	
Temperature Cycle	10 times repetition of cycle -40°C/30min →normal, temp/2 min →125°C/30min, measurement after normal temp/2 HRS.	
Solder Ability	Check for solder adhesion after 260±5°C for 3sec , The body immersion depth 1.5mm in molten solder	Evenly covered by solder.
Solder Heat	Measurement after 260±5°C solder for 10sec, The body immersion depth 1.5mm in molten solder	Conformed to rated spec.

Recommended Soldering Conditions

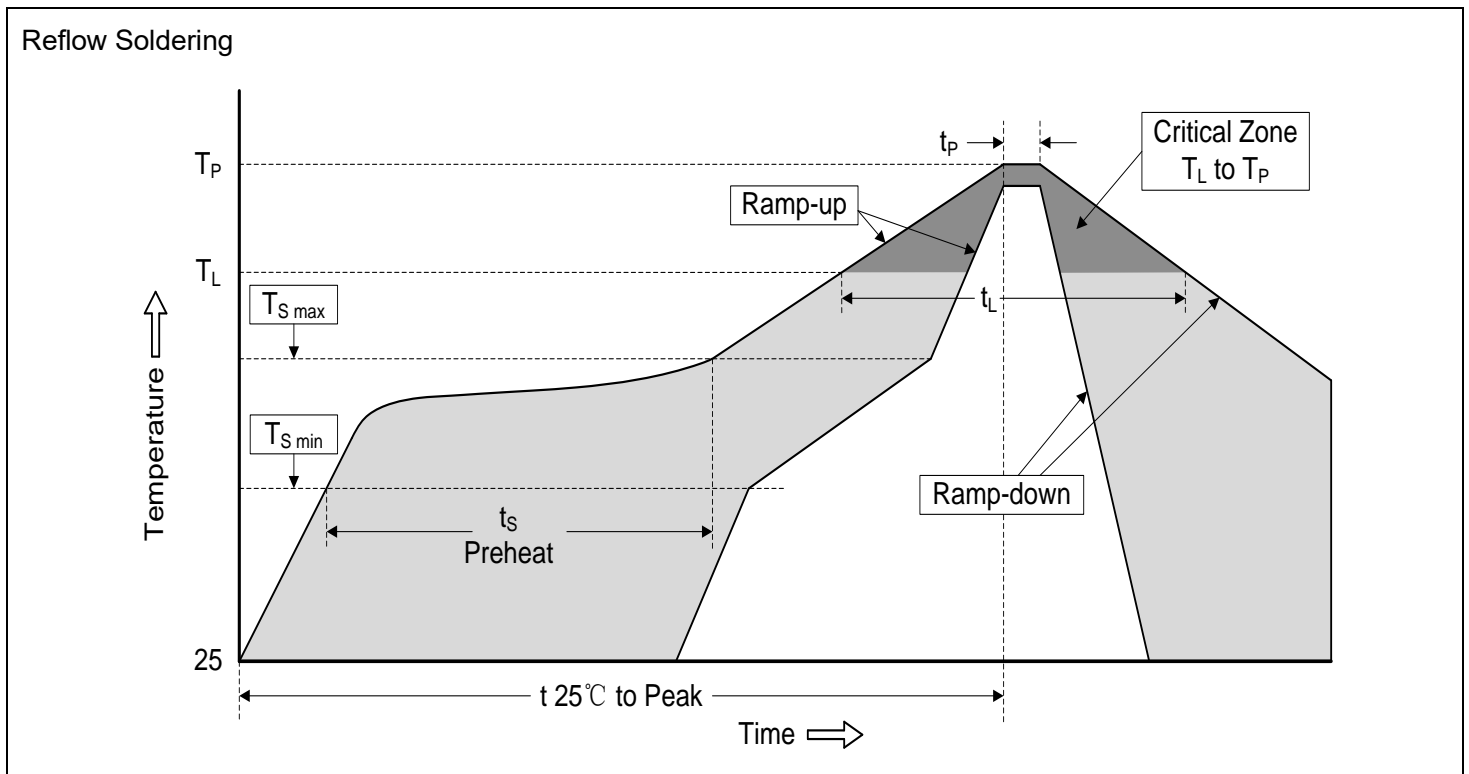

Recommended Conditions

Profile Feature	Pb-Free Assembly
Average ramp-up rate (T_L to T_P)	3°C/second max.
Preheat -Temperature Min ($T_{S\ min}$) -Temperature Max ($T_{S\ max}$) -Time (min to max) (ts)	150°C 200°C 60-180 seconds
$T_{S\ max}$ to T_L -Ramp-up Rate	3°C/second max.
Time maintained above: -Temperature (T_L) -Time (t_L)	217°C 60-150 seconds
Peak Temperature (T_P)	260°C
Time within 5°C of actual Peak Temperature (t_P)	20-40 seconds
Ramp-down Rate	6°C/second max.
Time 25°C to Peak Temperature	8 minutes max.

Packaging

Tape

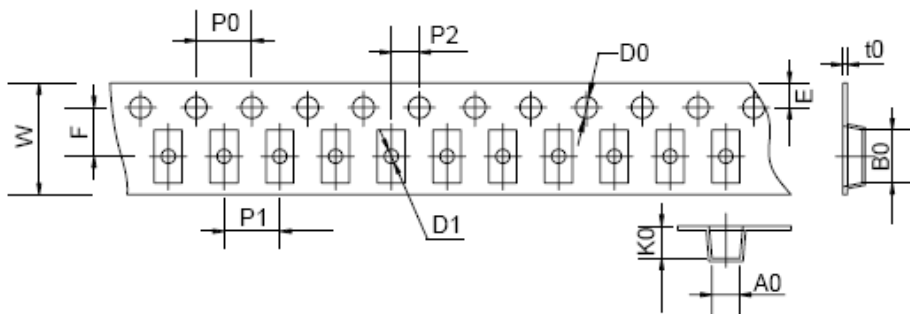

Items	Dimension (mm)	
	Spec.	Tolerance
W	8.00	±0.20
P0	4.00	±0.10
P1	4.00	±0.10
P2	2.00	±0.10
D0	1.55	±0.05
D1	1.00	±0.05
E	1.75	±0.10
F	3.50	±0.10
A0	2.00	±0.10
K0	2.00	±0.10
B0	3.80	±0.10
t0	0.30	±0.10
D	170.00	±2.00
d	13.00	±0.50
L	12.00	±2.00
t	1.20	±0.20
Quantity: 2500pcs		

Reel

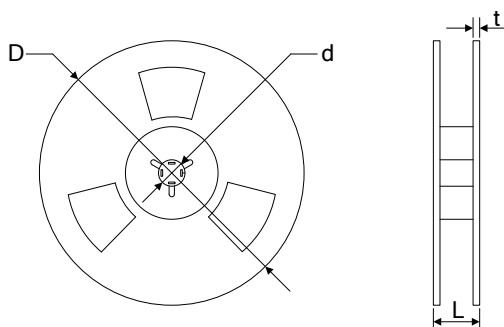

Legal Disclaimer

YAGEO, its distributors and agents (collectively, "YAGEO"), hereby disclaims any and all liabilities for any errors, inaccuracies or incompleteness contained in any product related information, including but not limited to product specifications, datasheets, pictures and/or graphics. YAGEO may make changes, modifications and/or improvements to product related information at any time and without notice.

YAGEO makes no representation, warranty, and/or guarantee about the fitness of its products for any particular purpose or the continuing production of any of its products. To the maximum extent permitted by law, YAGEO disclaims (i) any and all liability arising out of the application or use of any YAGEO product, (ii) any and all liability, including without limitation special, consequential or incidental damages, and (iii) any and all implied warranties, including warranties of fitness for a particular purpose, non-infringement and merchantability.

YAGEO products are designed for general purpose applications under normal operation and usage conditions. Please contact YAGEO for the applications listed below which require especially high reliability for the prevention of defects which might directly cause damage to the third party's life, body or property: Aerospace equipment (artificial satellite, rocket, etc.), Atomic energy-related equipment, Aviation equipment, Disaster prevention equipment, crime prevention equipment, Electric heating apparatus, burning equipment, Highly public information network equipment, data-processing equipment, Medical devices, Military equipment, Power generation control equipment, Safety equipment, Traffic signal equipment, Transportation equipment and Undersea equipment, or for any other application or use in which the failure of YAGEO products could result in personal injury or death, or serious property damage. Particularly **YAGEO Corporation and its affiliates do not recommend the use of commercial, automotive, and/or COTS grade products for high reliability applications or manned space flight.**

Information provided here is intended to indicate product specifications only. YAGEO reserves all the rights for revising this content without further notification, as long as products are unchanged. Any product change will be announced by PCN.