

Spezifikation für Freigabe / specification for release

Kunde / customer :
 Artikelnummer / part number : **74980111211**
 Bezeichnung : LAN-Übertrager WE-RJ45LAN 10/100BaseT
 description : LAN-Transformer WE-RJ45LAN 10/100BaseT



DATUM / DATE : 2012-09-24

A Mechanische Abmessungen / dimensions :

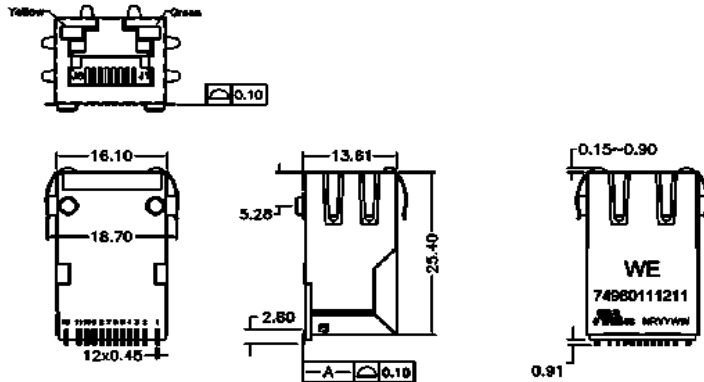

B Lötpad / soldering spec. :

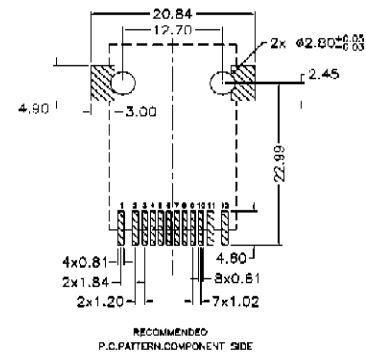

C Elektrische Eigenschaften / electrical properties :

Eigenschaften / properties	Testbedingungen / test conditions		Wert / value	Einheit / unit	tol.
Induktivität / Inductance	100kHz / 100mV @ 8mA DC-Bias	OCL	350	µH	min.
Übersetzungsverhältnis / Turns ratio	100kHz / 100mV	TR	1 : 1	Tx	
			1 : 1	Rx	
Insertion Loss	1-100MHz	IL	-1,0	dB	max.
Return Loss	1-30MHz @ 100Ω	RL	-18	dB	min.
	30-60 MHz @ 100Ω		-16		
	60-80MHz @ 100Ω		-12		
Common Mode Rejection	1-50MHz	CMR	-30	dB	min.
	50-130MHz		-20		
Crosstalk	1-10MHz	CT	-40	dB	min.
	30-60MHz		-35		
	60-100MHz		-30		

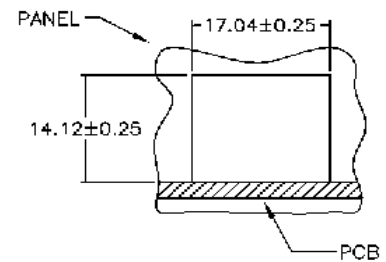

D Prüfgeräte / test equipment :

HP4395A

E Testbedingungen / test conditions :

Luftfeuchtigkeit / humidity: 33%
 Umgebungstemperatur / temperature: +25°C

F Werkstoffe & Zulassungen / material & approvals :

Basismaterial / base material: Ferrit/ ferrite
 Draht / wire: UEW 155°C
 Kontaktmaterial/ contact plating: 100% tin w. nickel underplating
 30µ"gold plating on contact area
 Gehäuse / housing: Thermoplastic UL-94V0
 LED: 1,8-2,8 V/ 20mA
 Shield: 50µ" nickel
 over 0.01" cooper alloy

G Eigenschaften / general specifications :

Betriebstemp. / operating temperature: -40°C - + 85°C
 Hochspannungsprüfung / Hipot test: 1500Vrms 1min.
 Geeignet für 10/100Base-TX gemäß IEEE 802.3u /
 Compliant with IEEE 802.3u for 10/100Base-TX-Applications
 Auto MDIX fähig / Auto MDIX capable

Freigabe erteilt / general release:	Kunde / customer		
Datum / date	Unterschrift / signature		
	Würth Elektronik		
Geprüft / checked	Kontrolliert / approved		
	Mle	Rev 04	2012-09-24
	Mle	Rev 03	2012-06-21
	Mle	Rev 02	2011-10-21
	Mle	Rev 01	2011-07-08
	Mle	Rev 00	2011-06-24
	Name	Änderung / modification	Datum / date

Würth Elektronik eiSos GmbH & Co.KG

D-74638 Waldenburg · Max-Eyth-Straße 1 - 3 · Germany · Telefon (+49) (0) 7942 - 945 - 0 · Telefax (+49) (0) 7942 - 945 - 400
<http://www.we-online.com>

Spezifikation für Freigabe / specification for release

Kunde / customer :
 Artikelnummer / part number : **74980111211**
 Bezeichnung : **LAN-Übertrager WE-RJ45LAN 10/100BaseT**
 description : **LAN-Transformer WE-RJ45LAN 10/100BaseT**



DATUM / DATE : 2012-09-24

H Schaltbild / Schematics :

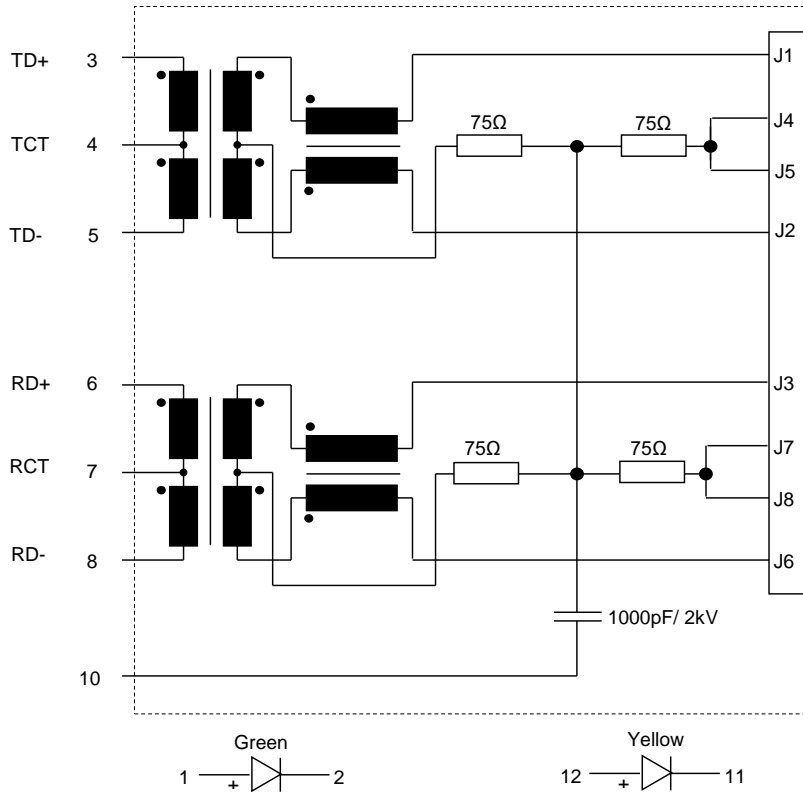

Freigabe erteilt / general release:	Kunde / customer			
.....	Mle	Rev 04	2012-09-24
Datum / date	Unterschrift / signature	Mle	Rev 03	2012-06-21
.....	Würth Elektronik	Mle	Rev 02	2011-10-21
.....	Mle	Rev 01	2011-07-08
Geprüft / checked	Kontrolliert / approved	Mle	Rev 00	2011-06-24
		Name	Änderung / modification	Datum / date

Würth Elektronik eiSos GmbH & Co.KG

D-74638 Waldenburg · Max-Eyth-Straße 1 - 3 · Germany · Telefon (+49) (0) 7942 - 945 - 0 · Telefax (+49) (0) 7942 - 945 - 400
<http://www.we-online.com>

Spezifikation für Freigabe / specification for release

Kunde / customer :
 Artikelnummer / part number : **7498011211**
 Bezeichnung : LAN-Übertrager WE-RJ45LAN 10/100BaseT
 description : LAN-Transformer WE-RJ45LAN 10/100BaseT



DATUM / DATE : 2012-09-24

I Verpackungsspezifikation / package specification :

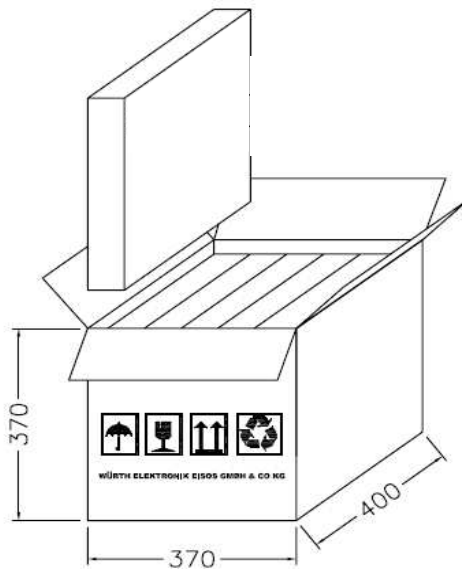
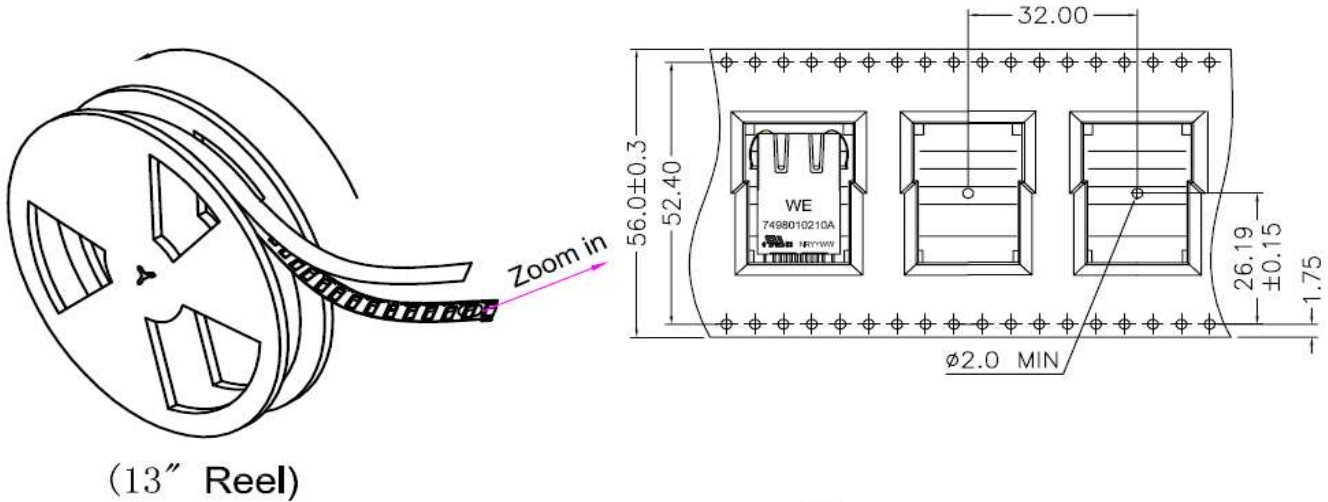

reel= 75pcs
 carton= 375pcs

dimensions in mm

Freigabe erteilt / general release:	Kunde / customer		
.....	Mle	Rev 04
Datum / date	Unterschrift / signature	Mle	Rev 03
.....	Würth Elektronik	Mle	Rev 02
.....	Mle	Rev 01
Geprüft / checked	Kontrolliert / approved	Mle	Rev 00
.....	Name	Änderung / modification
			Datum / date

This electronic component has been designed and developed for usage in general electronic equipment. Before incorporating this component into any equipment where higher safety and reliability is especially required or if there is the possibility of direct damage or injury to human body, for example in the range of aerospace, aviation, nuclear control, submarine, transportation, (automotive control, train control, ship control), transportation signal, disaster prevention, medical, public information network etc, Würth Elektronik eiSos GmbH must be informed before the design-in stage. In addition, sufficient reliability evaluation checks for safety must be performed on every electronic component which is used in electrical circuits that require high safety and reliability functions or performance.

Würth Elektronik eiSos GmbH & Co.KG

D-74638 Waldenburg · Max-Eyth-Straße 1 - 3 · Germany · Telefon (+49) (0) 7942 - 945 - 0 · Telefax (+49) (0) 7942 - 945 - 400
<http://www.we-online.com>