

# KOE

## JDI Group

Kaohsiung Opto-Electronics Inc.

FOR MESSRS : \_\_\_\_\_

DATE : May 23<sup>th</sup>, 2014

### CUSTOMER'S ACCEPTANCE SPECIFICATIONS

## TX20D34VM2BAB

### Contents

No.	ITEM	SHEET No.	PAGE
1	COVER	7B64PS 2701-TX20D34VM2BAB-3	1-1/1
2	RECORD OF REVISION	7B64PS 2702-TX20D34VM2BAB-3	2-1/2~2/2
3	GENERAL DATA	7B64PS 2703-TX20D34VM2BAB-3	3-1/1
4	ABSOLUTE MAXIMUM RATINGS	7B64PS 2704-TX20D34VM2BAB-3	4-1/1
5	ELECTRICAL CHARACTERISTICS	7B64PS 2705-TX20D34VM2BAB-3	5-1/2~2/2
6	OPTICAL CHARACTERISTICS	7B64PS 2706-TX20D34VM2BAB-3	6-1/2~2/2
7	BLOCK DIAGRAM	7B64PS 2707-TX20D34VM2BAB-3	7-1/1
8	RELIABILITY TESTS	7B64PS 2708-TX20D34VM2BAB-3	8-1/1
9	LCD INTERFACE	7B64PS 2709-TX20D34VM2BAB-3	9-1/7~7/7
10	OUTLINE DIMENSIONS	7B64PS 2710-TX20D34VM2BAB-3	10-1/2~2/2
11	APPEARANCE STANDARD	7B64PS 2711-TX20D34VM2BAB-3	11-1/3~3/3
12	PRECAUTIONS	7B64PS 2712-TX20D34VM2BAB-3	12-1/2~2/2
13	DESIGNATION OF LOT MARK	7B64PS 2713-TX20D34VM2BAB-3	13-1/1

ACCEPTED BY: \_\_\_\_\_

PROPOSED BY: S.Z Lin

## 2. RECORD OF REVISION

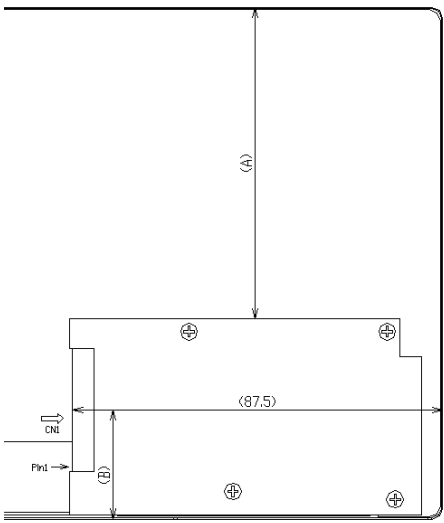
DATE	SHEET No.	SUMMARY																				
Dec.11,'13	7B64PS 2704- TX20D34VM2BAB -2 PAGE 4-1/1	<p>4. ABSOLUTE MAXIMUM RATINGS</p> <p>Changed :</p> <table border="1"> <thead> <tr> <th>Item</th> <th>Symbol</th> <th>Max.</th> <th>Unit</th> <th>Remarks</th> </tr> </thead> <tbody> <tr> <td>Backlight Input Voltage</td> <td><math>V_{LED}</math></td> <td>14</td> <td>V</td> <td>-</td> </tr> </tbody> </table> <p style="text-align: center;">↓</p> <table border="1"> <thead> <tr> <th>Item</th> <th>Symbol</th> <th>Max.</th> <th>Unit</th> <th>Remarks</th> </tr> </thead> <tbody> <tr> <td>Backlight Input Voltage</td> <td><math>V_{LED}</math></td> <td>15</td> <td>V</td> <td>-</td> </tr> </tbody> </table>	Item	Symbol	Max.	Unit	Remarks	Backlight Input Voltage	$V_{LED}$	14	V	-	Item	Symbol	Max.	Unit	Remarks	Backlight Input Voltage	$V_{LED}$	15	V	-
	Item	Symbol	Max.	Unit	Remarks																	
Backlight Input Voltage	$V_{LED}$	14	V	-																		
Item	Symbol	Max.	Unit	Remarks																		
Backlight Input Voltage	$V_{LED}$	15	V	-																		
7B64PS 2705- TX20D34VM2BAB -2 PAGE 5-1/2	<p>5.1 LCD CHARACTERISTICS</p> <p>Changed :</p> <table border="1"> <thead> <tr> <th>Item</th> <th>Symbol</th> <th>Condition</th> <th>Min.</th> </tr> </thead> <tbody> <tr> <td>Power Supply Voltage</td> <td><math>V_{DD}</math></td> <td>-</td> <td>2.3</td> </tr> </tbody> </table> <p style="text-align: center;">↓</p> <table border="1"> <thead> <tr> <th>Item</th> <th>Symbol</th> <th>Condition</th> <th>Min.</th> </tr> </thead> <tbody> <tr> <td>Power Supply Voltage</td> <td><math>V_{DD}</math></td> <td>-</td> <td>3.0</td> </tr> </tbody> </table>	Item	Symbol	Condition	Min.	Power Supply Voltage	$V_{DD}$	-	2.3	Item	Symbol	Condition	Min.	Power Supply Voltage	$V_{DD}$	-	3.0					
Item	Symbol	Condition	Min.																			
Power Supply Voltage	$V_{DD}$	-	2.3																			
Item	Symbol	Condition	Min.																			
Power Supply Voltage	$V_{DD}$	-	3.0																			
7B64PS 2705- TX20D34VM2BAB -2 PAGE 5-2/2	<p>5.2 BACKLIGH CHARACTERISTICS</p> <p>Note 1: Fig. 5.1 shows the LED backlight circuit. The circuit has 42 LEDs in total and R is 261 <math>\Omega</math> .</p> <p style="text-align: center;">↓</p> <p>Note 1: Fig. 5.1 shows the LED backlight circuit. The circuit has 42 LEDs in total and R is 280 <math>\Omega</math> .</p>																					
7B64PS 2710- TX20D34VM2BAB -2 PAGE 10-2/2	<p>10.2 REAR VIEW</p> <p>The dimension of (A) is changed from 65 to 73 mm.</p> <p>The dimension of (B) is changed from 20.6 to 25.6 mm.</p> <div style="text-align: center;">  </div>																					

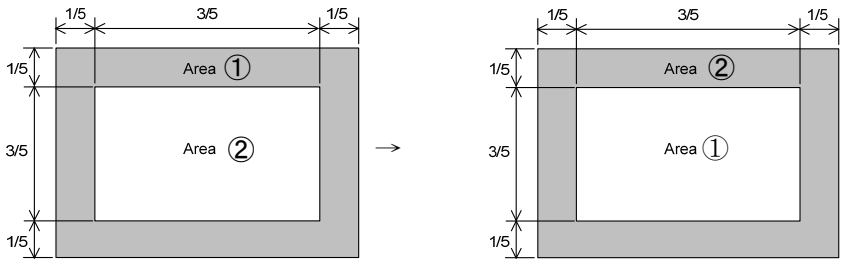
DATE	SHEET No.	SUMMARY																				
Dec.11,'13	7B64PS 2711 – TX20D34VM2BAB-2 Page 11 – 2/3	<p>11.2 LCD APPEARANCE SPECIFICATION</p> <p>Revised :</p> 																				
	7B64PS 2711 – TX20D34VM2BAB-2 Page 11 – 3/3	<p>11.2 LCD APPEARANCE SPECIFICATION</p> <p>Removed : LED BACKLIGHT APPEARANCE</p>																				
May 23,'14	7B64PS 2703- TX20D34VM2BAB -4 PAGE 3-1/1	<p>3.1 DISPLAY FEATURES</p> <p>Changed :</p> <table border="1" data-bbox="560 768 1353 815"> <tr> <td>Power Consumption</td> <td>0.5W for LCD; 1.3W for backlight.</td> </tr> </table> <p style="text-align: center;">↓</p> <table border="1" data-bbox="560 864 1353 911"> <tr> <td>Power Consumption</td> <td>0.9W for LCD; 1.3W for backlight.</td> </tr> </table>	Power Consumption	0.5W for LCD; 1.3W for backlight.	Power Consumption	0.9W for LCD; 1.3W for backlight.																
Power Consumption	0.5W for LCD; 1.3W for backlight.																					
Power Consumption	0.9W for LCD; 1.3W for backlight.																					
	7B64PS 2705- TX20D34VM2BAB -4 PAGE 5-1/2	<p>5.1 LCD CHARACTERISTICS</p> <p>Changed :</p> <table border="1" data-bbox="552 1010 1417 1104"> <thead> <tr> <th>Item</th> <th>Min.</th> <th>Typ.</th> <th>Max.</th> <th>Unit</th> </tr> </thead> <tbody> <tr> <td>Power Supply Current</td> <td>-</td> <td>150</td> <td>180</td> <td>mA</td> </tr> </tbody> </table> <p style="text-align: center;">↓</p> <table border="1" data-bbox="552 1153 1417 1247"> <thead> <tr> <th>Item</th> <th>Min.</th> <th>Typ.</th> <th>Max.</th> <th>Unit</th> </tr> </thead> <tbody> <tr> <td>Power Supply Current</td> <td>-</td> <td>270</td> <td>377</td> <td>mA</td> </tr> </tbody> </table>	Item	Min.	Typ.	Max.	Unit	Power Supply Current	-	150	180	mA	Item	Min.	Typ.	Max.	Unit	Power Supply Current	-	270	377	mA
Item	Min.	Typ.	Max.	Unit																		
Power Supply Current	-	150	180	mA																		
Item	Min.	Typ.	Max.	Unit																		
Power Supply Current	-	270	377	mA																		

### 3. GENERAL DATA

#### 3.1 DISPLAY FEATURES

This module is a 8.0" WVGA of 16:9 format amorphous silicon TFT. The pixel format is vertical stripe and sub pixels are arranged as R(red), G(green), B(blue) sequentially. This display is RoHS compliant, and COG (chip on glass) technology and LED backlight are applied on this display.

Part Name	TX20D34VM2BAB
Module Dimensions	189.0(W) mm x 120.0(H) mm x 7.5 (D) mm
LCD Active Area	174.0(W) mm x104.4(H) mm
Pixel Pitch	0.2175(W) mm x 0.2175 (H) mm
Resolution	800 x 3(RGB)(W) x 480(H) Dots
Color Pixel Arrangement	R, G, B Vertical stripe
LCD Type	Transmissive Color TFT; Normally White
Display Type	Active Matrix
Number of Colors	262k Colors (6-bit RGB)
Backlight	Light Emitting Diode (LED)
Weight	165 g
Interface	LVDS ; 20 pins
Power Supply Voltage	3.3V for LCD; 12.0V for backlight
Power Consumption	0.9W for LCD; 2.0W for backlight
Viewing Direction	12 O'clock (without image inversion and least brightness change) 6 O'clock (contrast peak located at)

## 4. ABSOLUTE MAXIMUM RATINGS

Item	Symbol	Min.	Max.	Unit	Remarks
Supply Voltage	V <sub>DD</sub>	-0.5	5.0	V	-
Input Voltage of Logic	V <sub>I</sub>	-0.5	5.0	V	Note 1
Operating Temperature	Top	-30	80	°C	Note 2
Storage Temperature	Tst	-30	80	°C	Note 2
Backlight Input Voltage	V <sub>LED</sub>	-	15	V	-

Note 1: The rating is defined for the signal voltage of the interface such as CLK and pixel data pairs.

Note 2: The maximum rating is defined as above based on the panel surface temperature, which might be different from ambient temperature after assembling the panel into the application. Moreover, some temperature-related phenomenon as below needed to be noticed:

- Background color, contrast and response time would be different in temperatures other than 25°C.
- Operating under high temperature will shorten LED lifetime.

# 5. ELECTRICAL CHARACTERISTICS

## 5.1 LCD CHARACTERISTICS

$T_a = 25\text{ }^\circ\text{C}$ ,  $V_{SS} = 0\text{V}$

Item	Symbol	Condition	Min.	Typ.	Max.	Unit	Remarks
Power Supply Voltage	$V_{DD}$	-	3.0	3.3	3.6	V	-
Differential Input Voltage for LVDS Receiver Threshold	$V_I$	$V_{IH}$	-	-	+100	mV	Note 1
		$V_{IL}$	-100	-	-		
Power Supply Current	$I_{DD}$	$V_{DD}-V_{SS} = 3.3\text{V}$	-	270	377	mA	Note 2,3
Frame Frequency	$f_{Frame}$	-	-	60	66	Hz	Note 4
CLK Frequency	$f_{CLK}$	-	25	33.3	40	MHz	

Note 1: VCM 1.2V is common mode voltage of LVDS transmitter and receiver. The input terminal of LVDS transmitter is terminated with  $100\Omega$ .

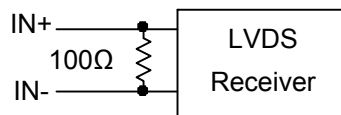

Note 2: An all black check pattern is used when measuring  $I_{DD}$ .  $f_{Frame}$  is set to 60Hz.

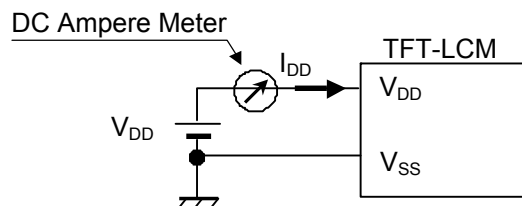

Note 3: 0.315A fuse is applied in the module for  $I_{DD}$ . For display activation and protection purpose, power supply is recommended larger than 1.0A to start the display and break fuse once any short circuit occurred.

Note 4: For LVDS transmitter input.

## 5.2 BACKLIGHT CHARACTERISTICS

$T_a = 25^\circ\text{C}$

Item	Symbol	Condition	Min.	Typ.	Max.	Unit	Remarks
LED Input Voltage	$V_{LED}$	Backlight Unit	11.5	12.0	12.5	V	Note 1
LED Forward Current	$I_{LED}$	Backlight Unit	-	168	-	mA	-
LED Lifetime	-	$I_{LED}=168\text{ mA}$	-	50K	-	hrs	Note 2,3

Note 1: Fig. 5.1 shows the LED backlight circuit. The circuit has 42 LEDs in total and R is  $280\ \Omega$ .

Note 2: The estimated lifetime is specified as the time to reduce 50% brightness by applying 168 mA at  $25^\circ\text{C}$ .

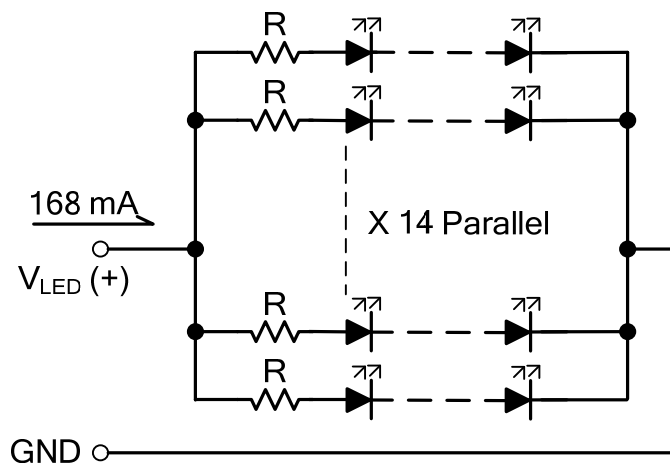

Fig 5.1

Note 3: By applying different  $I_{LED}$ , the estimated brightness and LED life time curves are shown as Fig 5.2 and Fig 5.3 for various environment use.

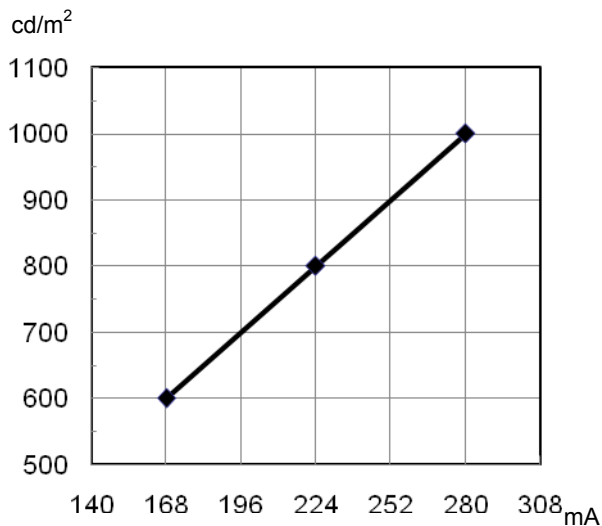

Fig 5.2 LED Current v.s. Brightness

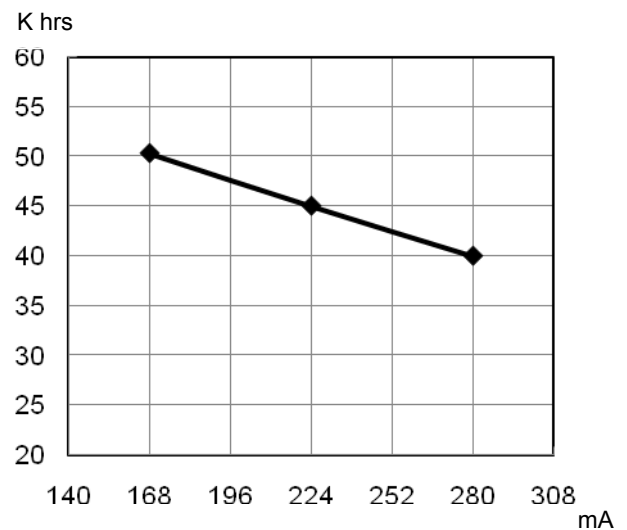

Fig 5.3 LED Current v.s. Lifetime

## 6. OPTICAL CHARACTERISTICS

The optical characteristics are measured based on the conditions as below:

- Supplying the signals and voltages defined in the section of electrical characteristics.
- The ambient temperature is 25 °C .
- In the dark room less than 100 lx, the equipment has been set for the measurements as shown in Fig 6.1.

$$T_a = 25\text{ }^\circ\text{C}, f_{Frame} = 60\text{ Hz}, V_{DD} = 3.3\text{V}$$

Item	Symbol	Condition	Min.	Typ.	Max.	Unit	Remarks	
Brightness of White	-	$I_{LED} = 168\text{mA}$ $\phi = 0^\circ, \theta = 0^\circ$	500	600	-	cd/m <sup>2</sup>	Note 1	
Brightness Uniformity	-		70	-	-	%	Note 2	
Contrast Ratio	CR		300	600	-	-	Note 3	
Response Time	Tr + Tf	$\phi = 0^\circ, \theta = 0^\circ$	-	20	-	ms	Note 4	
NTSC Ratio	-	$\phi = 0^\circ, \theta = 0^\circ$	-	60	-	%	-	
Viewing Angle	$\theta_x$	$\phi = 0^\circ, CR \geq 10$	60	80	-	Degree	Note 5	
	$\theta_{x'}$	$\phi = 180^\circ, CR \geq 10$	60	80	-			
	$\theta_y$	$\phi = 90^\circ, CR \geq 10$	50	60	-			
	$\theta_{y'}$	$\phi = 270^\circ, CR \geq 10$	70	80	-			
Color Chromaticity	Red	X	$\phi = 0^\circ, \theta = 0^\circ$	0.59	0.64	0.69	-	Note 6
		Y		0.29	0.34	0.39		
	Green	X		0.31	0.36	0.41		
		Y		0.53	0.58	0.63		
	Blue	X		0.09	0.14	0.19		
		Y		0.03	0.08	0.13		
	White	X		0.24	0.29	0.34		
		Y		0.26	0.31	0.36		

Note 1: The brightness is measured from 9 point average value of the panel, P5 in Fig. 6.2, for the typical value.

Note 2: The brightness uniformity is calculated by the equation as below:

$$\text{Brightness uniformity} = \frac{\text{Min. Brightness}}{\text{Max. Brightness}} \times 100\%$$

which is based on the brightness values of the 9 points measured by BM-5 as shown in Fig. 6.2.

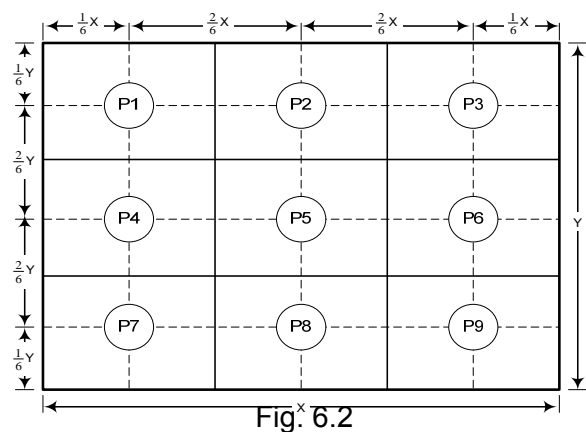
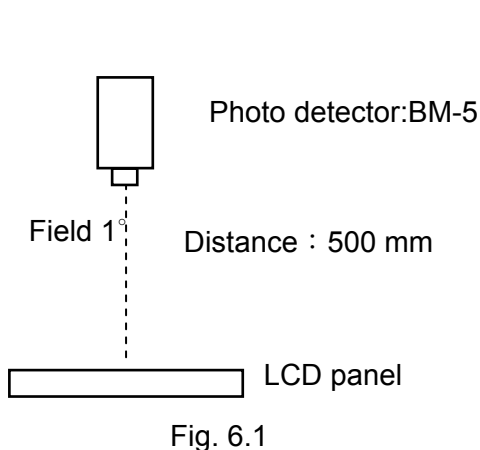



Note 3: The Contrast ratio is measured from the center point of the panel, P5, and defined as the following equation:

$$CR = \frac{\text{Brightness of White}}{\text{Brightness of Black}}$$

Note 4: The definition of response time is shown in Fig. 6.3. The rising time is the period from 90% brightness to 10% brightness when the data is from white to black. Oppositely, falling time is the period from 10% brightness rising to 90% brightness.

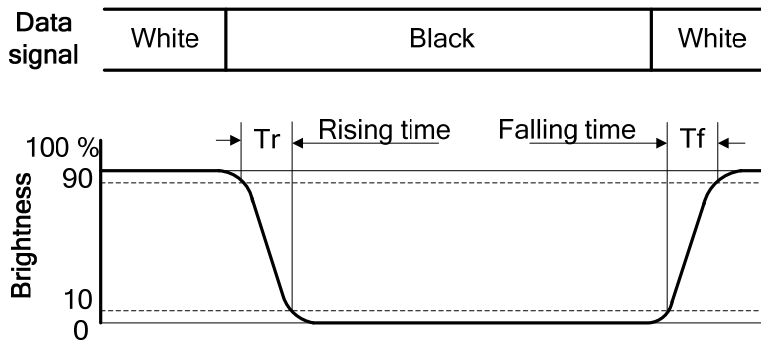

Fig. 6.3

Note 5: The definition of viewing angle is shown in Fig. 6.4. Angle  $\phi$  is used to represent viewing directions, for instance,  $\phi = 270^\circ$  means 6 o'clock, and  $\phi = 0^\circ$  means 3 o'clock. Moreover, angle  $\theta$  is used to represent viewing angles from axis Z toward plane XY.

The viewing direction of this display is 12 o'clock, which means that a photograph with gray scale would not be reversed in color and the brightness change would be less from this direction. However, the best contrast peak would be located at 6 o'clock.

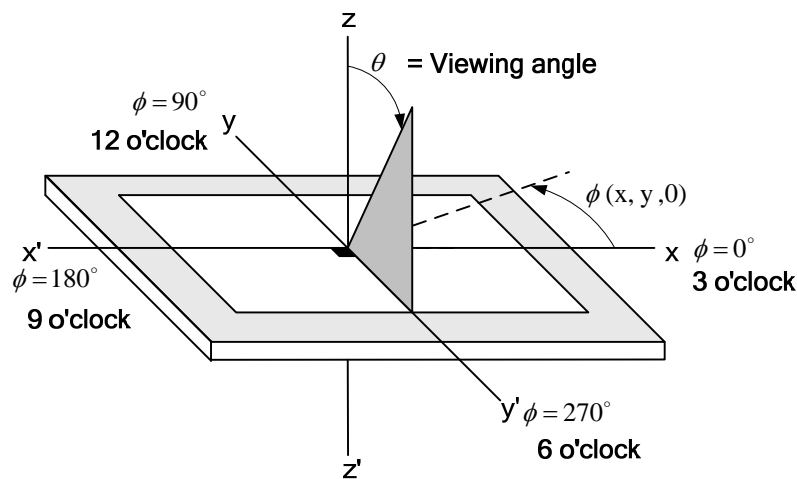
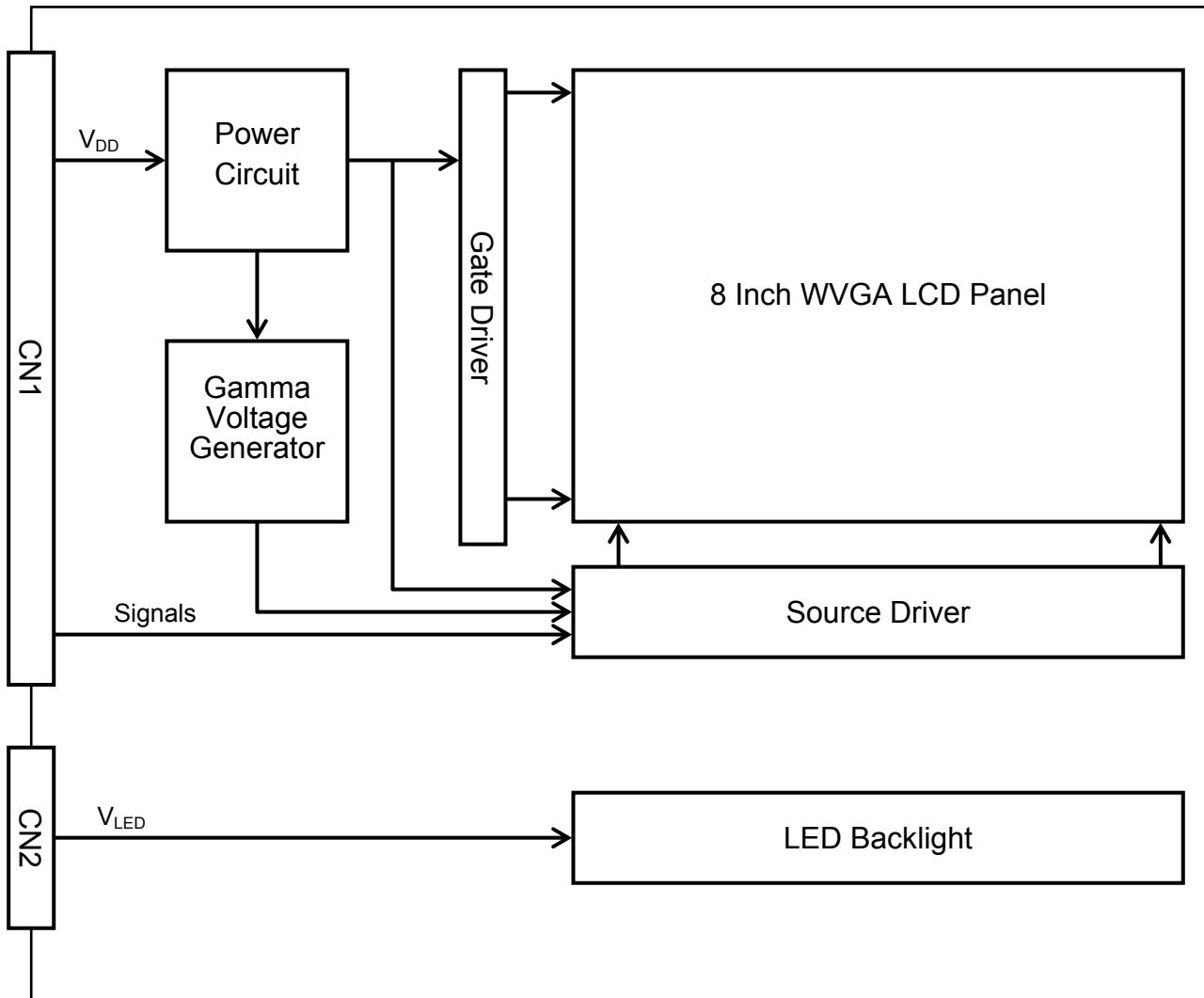

Fig. 6.4

Note 6: The color chromaticity is measured from the center point of the panel, P5, as shown in Fig. 6.2.

## 7. BLOCK DIAGRAM



Note : Signals are CLK and pixel data pairs.

## 8. RELIABILITY TESTS

Test Item	Condition	
High Temperature	1) Operating 2) 80 °C	240 hrs
Low Temperature	1) Operating 2) -30 °C	240 hrs
High Temperature	1) Storage 2) 80 °C	240 hrs
Low Temperature	1) Storage 2) -30 °C	240 hrs
Heat Cycle	1) Operating 2) -20 °C ~70 °C 3) 3hrs~1hr~3hrs	240 hrs
Thermal Shock	1) Non-Operating 2) -35 °C ↔ 85 °C 3) 0.5 hr ↔ 0.5 hr	240 hrs
High Temperature & Humidity	1) Operating 2) 40 °C & 85%RH 3) Without condensation	240 hrs (Note 3)
Vibration	1) Non-Operating 2) 20~200 Hz 3) 2G 4) X, Y, and Z directions	1 hr for each direction
Mechanical Shock	1) Non-Operating 2) 10 ms 3) 50G 4) ±X, ±Y and ±Z directions	Once for each direction
ESD	1) Operating 2) Tip: 150 pF, 330 Ω 3) Air discharge for glass: ± 8KV 4) Contact discharge for metal frame: ± 8KV	1) Glass: 9 points 2) Metal frame: 8 points (Note 4)

Note 1: Display functionalities are inspected under the conditions defined in the specification after the reliability tests.

Note 2: The display is not guaranteed for use in corrosive gas environments.

Note 3: Under the condition of high temperature & humidity, if the temperature is higher than 40°C, the humidity needs to be reduced as Fig. 8.1 shown.

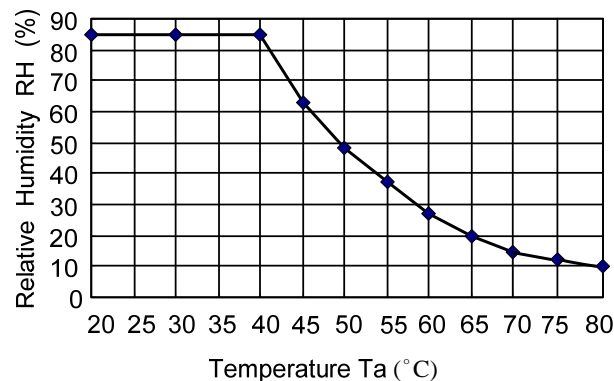

Fig. 8.1

Note 4: All pins of LCD interface (CN1) have been tested by ± 100V contact discharge of ESD under non-operating condition.

## 9. LCD INTERFACE

### 9.1 INTERFACE PIN CONNECTIONS

The display interface connector (CN1) is FI-SEB20P-HF13E-E1500 made by JAE and pin assignment is as below:

Pin No.	Signal	Signal	Pin No.	Signal	Signal
1	V <sub>DD</sub>	Power Supply for Logic	11	IN2-	B2~B5, DE
2	V <sub>DD</sub>		12	IN2+	
3	V <sub>SS</sub>	GND	13	V <sub>SS</sub>	GND
4	V <sub>SS</sub>		14	CLK IN-	Pixel Clock
5	IN0-	R0~R5, G0	15	CLK IN+	
6	IN0+		16	V <sub>SS</sub>	GND
7	V <sub>SS</sub>	GND	17	NC	No Connection
8	IN1-	G1~G5, B0~B1	18	NC	No Connection
9	IN1+		19	NC	No Connection
10	V <sub>SS</sub>	GND	20	TP	Note 2

Note 1: IN n- and IN n+ (n=0, 1, 2), CLK IN- and CLK IN+ should be wired by twist-pairs or side-by-side FPC patterns, respectively.

Note 2: Pin 20 is for internal test only, please keep it open.

The backlight interface connector is BHR-03VS-1 made by JST, and pin assignment of backlight is as below:

Pin No.	Signal	Level	Function
1	V <sub>LED+</sub>	-	Power Supply for LED
2	NC	-	No connection
3	V <sub>LED-</sub>	-	GND

## 9.2 LVDS INTERFACE

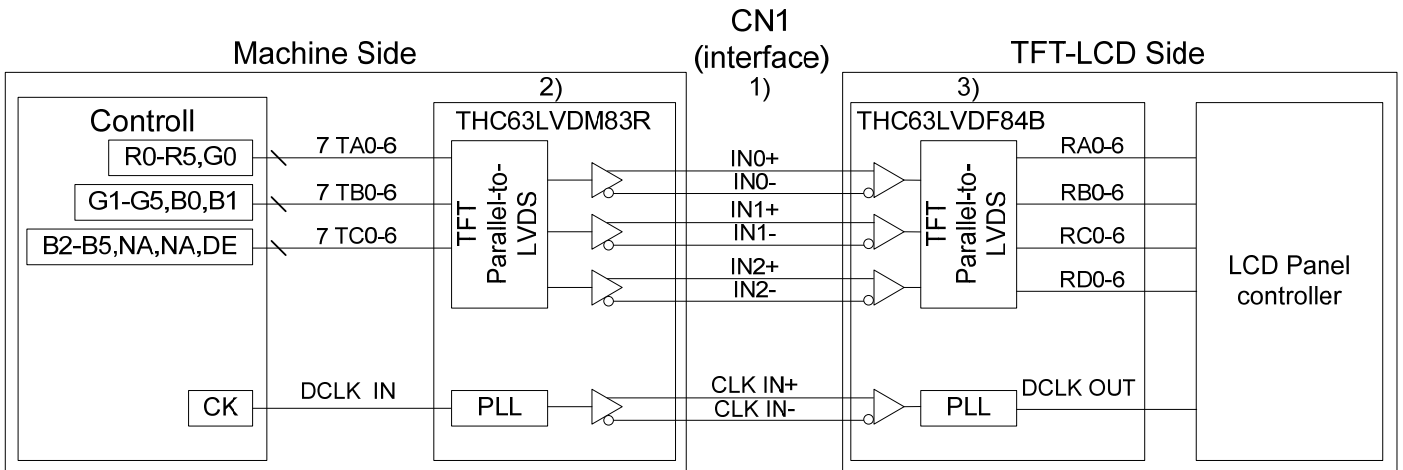

Note 1: LVDS cable impedance should be 100 ohms per signal line when each 2-lines (+, -) is used in differential mode.

Note 2: The recommended transmitter, THC63LVDM83R, is made by Thine or equivalent, which is not contained in the module.

Note 3: The receiver built-in the module is THC63LVDF84B made by Thine.

## 9.3 LVDS DATA FORMAT

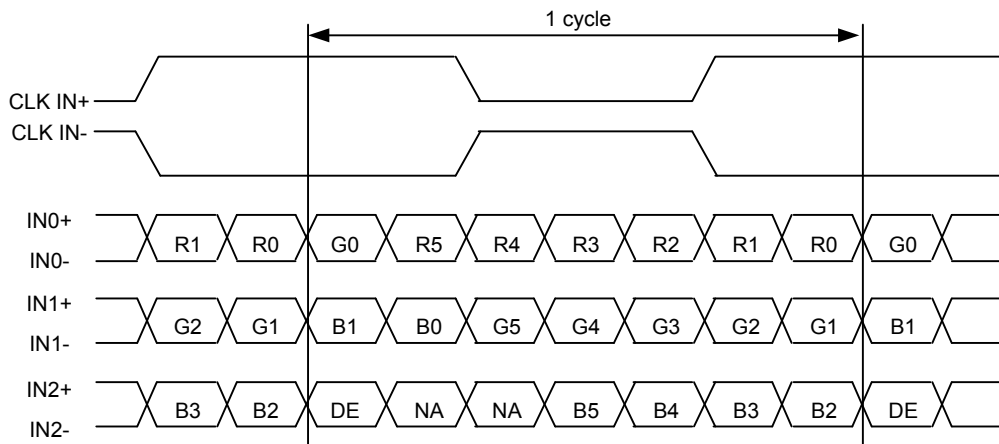

DE: Display Enable

NA: Not Available

## 9.4 TIMING CHART

### A. DE MODE

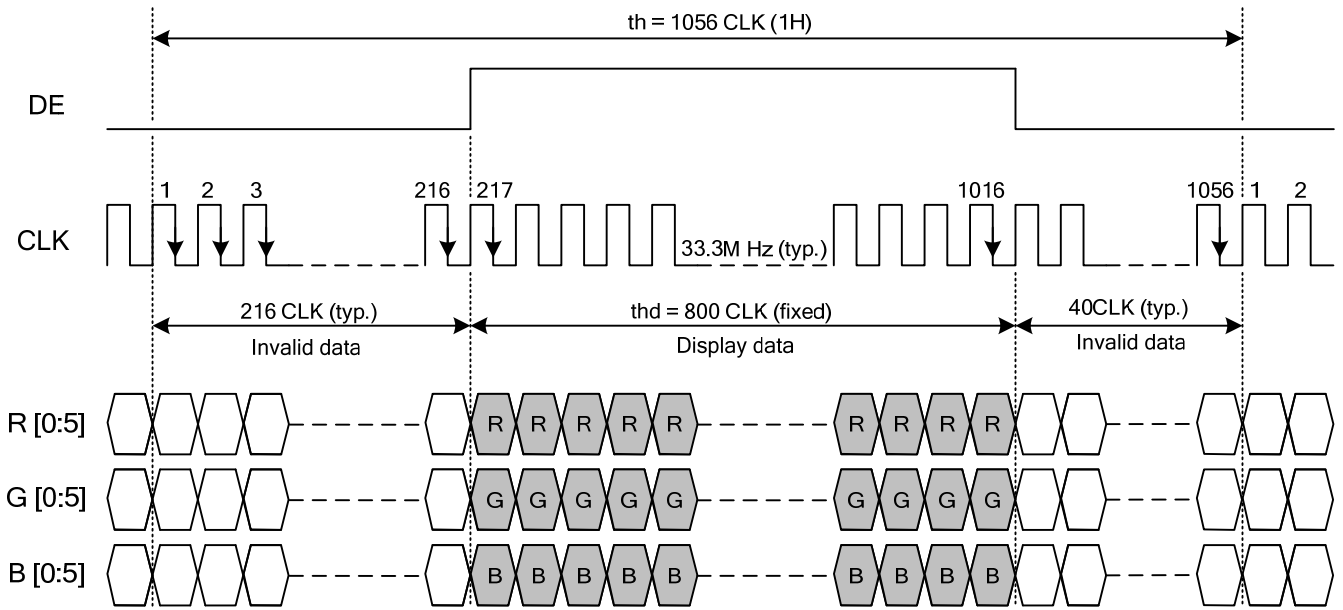

Fig. 9.1 Horizontal Timing

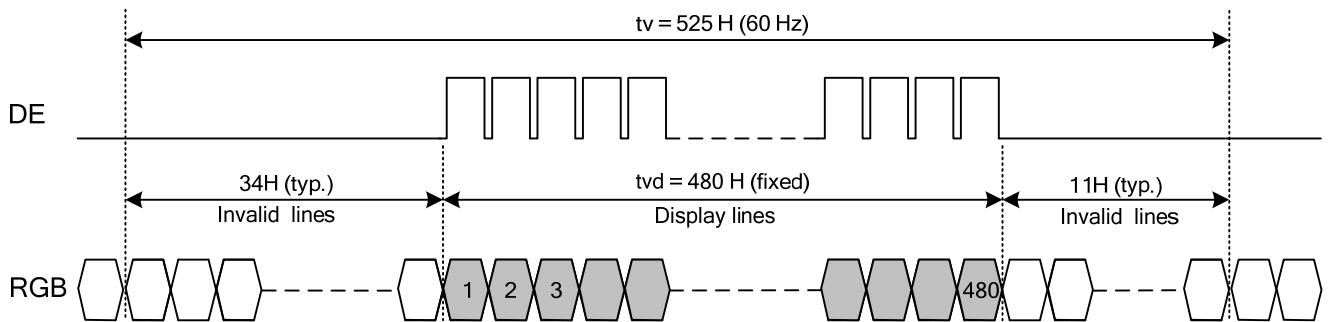

Fig. 9.2 Vertical Timing

### B. CLOCK AND DATA INPUT TIMING

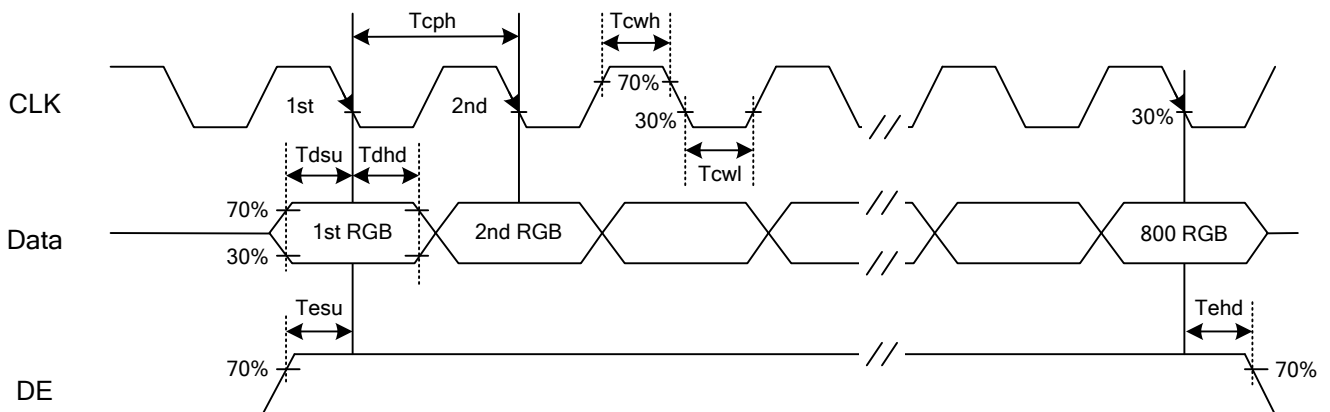

Fig. 9.3 Setup & Hold Time of Data and DE signal.

## 9.5 TIMING TABLE

The column of timing sets including minimum, typical, and maximum as below are based on the best optical performance, frame frequency (Vsync) = 60 Hz to define.

### A. DE MODE

	Item	Symbol	Min.	Typ.	Max.	Unit
Horizontal	CLK Frequency	fclk	25	33.3	40	M Hz
	Display Data	thd	800	800	800	CLK
	Cycle Time	th	841	1056	1088	
Vertical	Display Data	tvd	480	480	480	H
	Cycle Time	tv	495	525	610	

### B. CLOCK AND DATA INPUT TIMING

	Item	Symbol	Min.	Typ.	Max.	Unit
CLK	Duty	Tcwh	40	50	60	%
	Cycle Time	Tcph	-	30	-	ns
Vsync	Setup Time	Tvsu	5	-	-	
	Hold Time	Tvhd	5	-	-	
Hsync	Setup Time	Thsu	5	-	-	
	Hold Time	Thhd	5	-	-	
Data	Setup Time	Tdsu	5	-	-	
	Hold Time	Tdhd	5	-	-	
DE	Setup Time	Tesu	5	-	-	
	Hold Time	Tehd	5	-	-	

## 9.6 LVDS RECEIVER TIMING

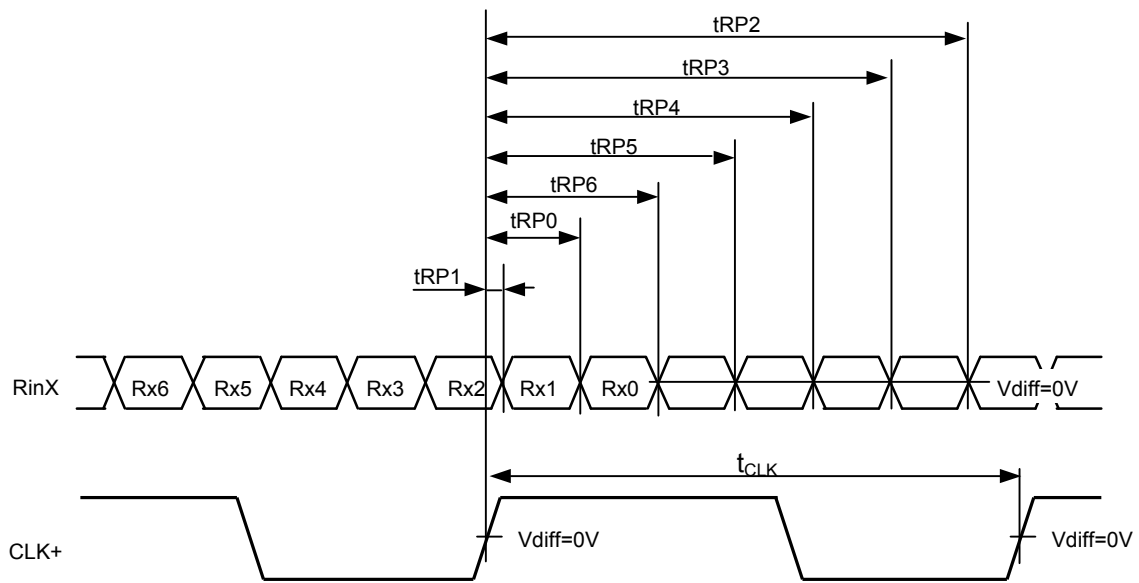

$$\text{RinX} = (\text{RinX}+) - (\text{RinX}-) \quad (X=0, 1, 2)$$

	Item	Symbol	Min.	Typ.	Max.	Unit
CLK	Cycle frequency	$1/t_{\text{CLK}}$	25	33.3	40	MHz
RinX (X=0,1,2)	0 data position	tRP0	$1/7 * t_{\text{CLK}} - 0.49$	$1/7 * t_{\text{CLK}}$	$1/7 * t_{\text{CLK}} + 0.49$	ns
	1st data position	tRP1	-0.49	0	+0.49	
	2nd data position	tRP2	$6/7 * t_{\text{CLK}} - 0.49$	$6/7 * t_{\text{CLK}}$	$6/7 * t_{\text{CLK}} + 0.49$	
	3rd data position	tRP3	$5/7 * t_{\text{CLK}} - 0.49$	$5/7 * t_{\text{CLK}}$	$5/7 * t_{\text{CLK}} + 0.49$	
	4th data position	tRP4	$4/7 * t_{\text{CLK}} - 0.49$	$4/7 * t_{\text{CLK}}$	$4/7 * t_{\text{CLK}} + 0.49$	
	5th data position	tRP5	$3/7 * t_{\text{CLK}} - 0.49$	$3/7 * t_{\text{CLK}}$	$3/7 * t_{\text{CLK}} + 0.49$	
	6th data position	tRP6	$2/7 * t_{\text{CLK}} - 0.49$	$2/7 * t_{\text{CLK}}$	$2/7 * t_{\text{CLK}} + 0.49$	



## 9.7 POWER SEQUENCE

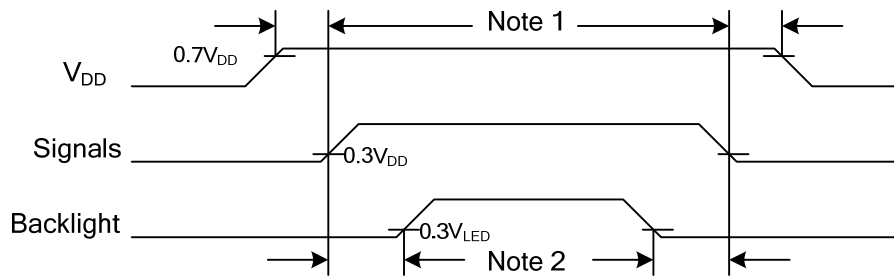

Note 1: In order to avoid any damages,  $V_{DD}$  has to be applied before all other signals. The opposite is true for power off where  $V_{DD}$  has to be remained on until all other signals have been switch off. The recommended time period is 1 second. Hot plugging might cause display damage due to incorrect power sequence, please pay attention on interface connecting before power on.

Note 2: In order to avoid showing uncompleted patterns in transient state. It is recommended that switching the backlight on is delayed for 1 second after the signals have been applied. The opposite is true for power off where the backlight has to be switched off 1 second before the signals are removed.

### 9.8 DATA INPUT for DISPLAY COLOR

Input color		Red Data						Green Data						Blue Data					
		R5	R4	R3	R2	R1	R0	G5	G4	G3	G2	G1	G0	B5	B4	B3	B2	B1	B0
		MSB			LSB			MSB			LSB			MSB			LSB		
Basic color	Black	0	0	0	0	0	0	0	0	0	0	0	0	0	0	0	0	0	0
	Red(63)	1	1	1	1	1	1	0	0	0	0	0	0	0	0	0	0	0	0
	Green(63)	0	0	0	0	0	0	1	1	1	1	1	1	0	0	0	0	0	0
	Blue(63)	0	0	0	0	0	0	0	0	0	0	0	0	1	1	1	1	1	1
	Cyan	0	0	0	0	0	0	1	1	1	1	1	1	1	1	1	1	1	1
	Magenta	1	1	1	1	1	1	0	0	0	0	0	0	1	1	1	1	1	1
	Yellow	1	1	1	1	1	1	1	1	1	1	1	1	0	0	0	0	0	0
	White	1	1	1	1	1	1	1	1	1	1	1	1	1	1	1	1	1	1
Red	Black	0	0	0	0	0	0	0	0	0	0	0	0	0	0	0	0	0	0
	Red (1)	0	0	0	0	0	1	0	0	0	0	0	0	0	0	0	0	0	0
	Red (2)	0	0	0	0	1	0	0	0	0	0	0	0	0	0	0	0	0	0
	:	:	:	:	:	:	:	:	:	:	:	:	:	:	:	:	:	:	:
	:	:	:	:	:	:	:	:	:	:	:	:	:	:	:	:	:	:	:
	Red (62)	1	1	1	1	1	0	0	0	0	0	0	0	0	0	0	0	0	0
	Red (63)	1	1	1	1	1	1	0	0	0	0	0	0	0	0	0	0	0	0
Green	Black	0	0	0	0	0	0	0	0	0	0	0	0	0	0	0	0	0	0
	Green (1)	0	0	0	0	0	0	0	0	0	0	0	1	0	0	0	0	0	0
	Green (2)	0	0	0	0	0	0	0	0	0	0	1	0	0	0	0	0	0	0
	:	:	:	:	:	:	:	:	:	:	:	:	:	:	:	:	:	:	:
	:	:	:	:	:	:	:	:	:	:	:	:	:	:	:	:	:	:	:
	Green (62)	0	0	0	0	0	0	1	1	1	1	1	0	0	0	0	0	0	0
	Green (63)	0	0	0	0	0	0	1	1	1	1	1	1	0	0	0	0	0	0
Blue	Black	0	0	0	0	0	0	0	0	0	0	0	0	0	0	0	0	0	0
	Blue (1)	0	0	0	0	0	0	0	0	0	0	0	0	0	0	0	0	0	1
	Blue (2)	0	0	0	0	0	0	0	0	0	0	0	0	0	0	0	0	1	0
	:	:	:	:	:	:	:	:	:	:	:	:	:	:	:	:	:	:	:
	:	:	:	:	:	:	:	:	:	:	:	:	:	:	:	:	:	:	:
	Blue (62)	0	0	0	0	0	0	0	0	0	0	0	0	1	1	1	1	1	0
	Blue (63)	0	0	0	0	0	0	0	0	0	0	0	0	1	1	1	1	1	1

# 10. OUTLINE DIMENSIONS

## 10.1 FRONT VIEW

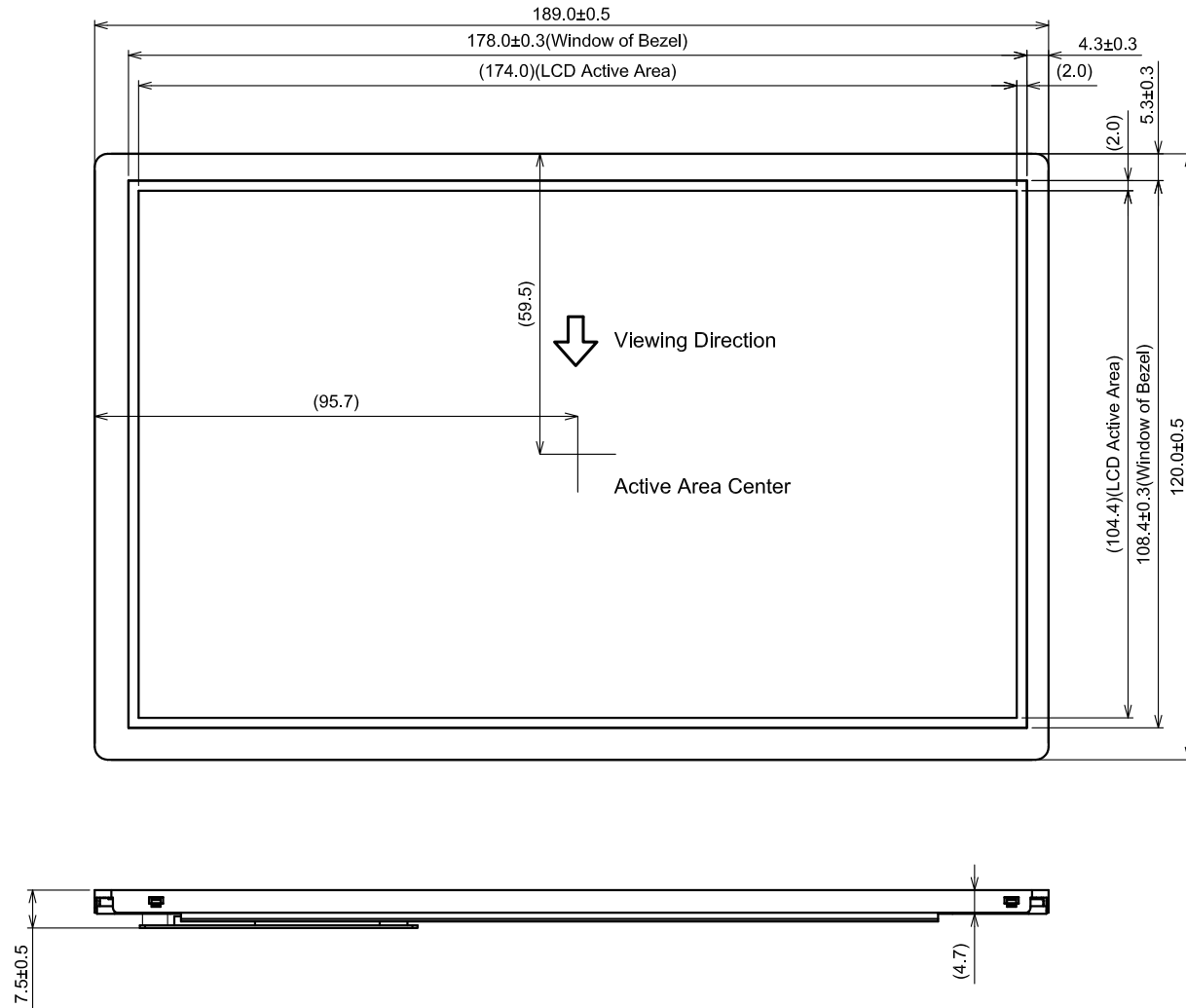

General Tolerance:  $\pm 0.5$   
 Scale : NTS  
 Unit : mm

10.2 REAR VIEW

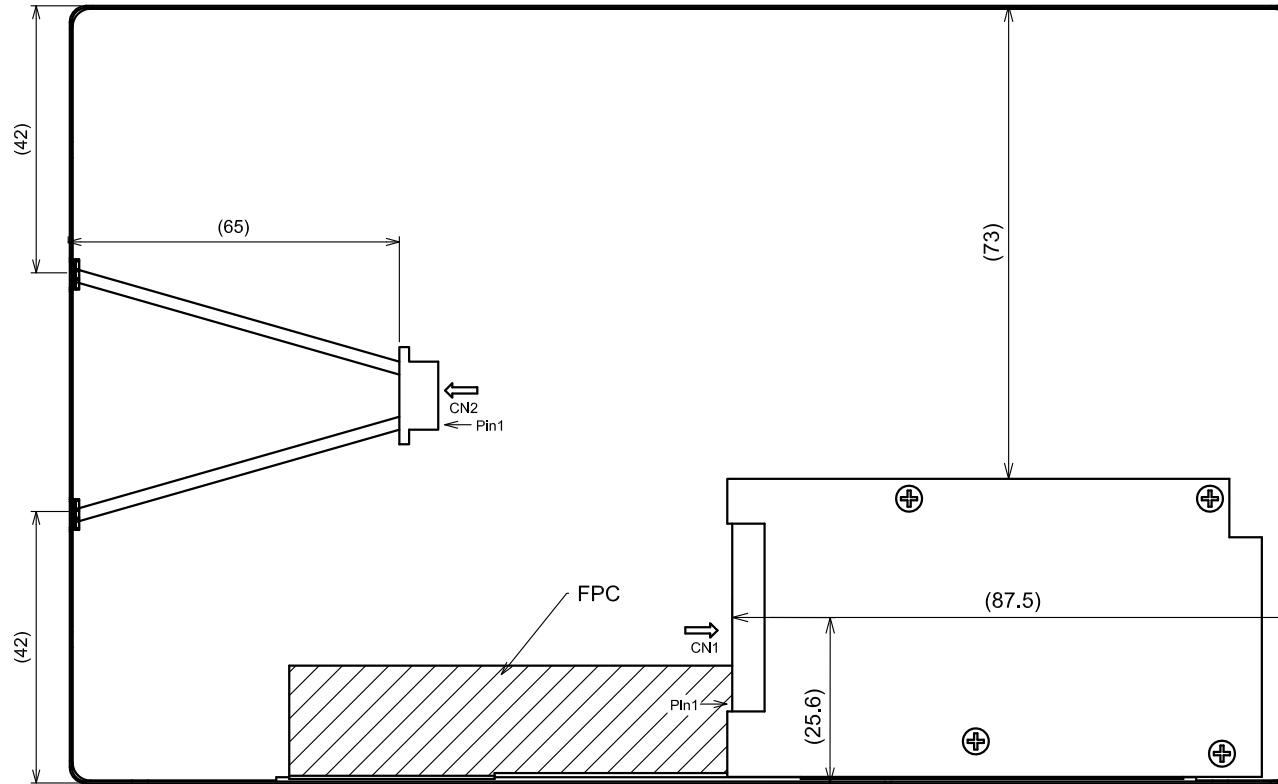

General Tolerance:±0.5  
 Scale : NTS  
 Unit : mm

# 11. APPEARANCE STANDARD

The appearance inspection is performed in a room around 500~1000 lx based on the conditions as below:

- The distance between inspector's eyes and display is 30 cm.
- The viewing zone is defined with angle  $\theta$  shown in Fig. 11.1 The inspection should be performed within  $45^\circ$  when display is shut down. The inspection should be performed within  $5^\circ$  when display is power on.

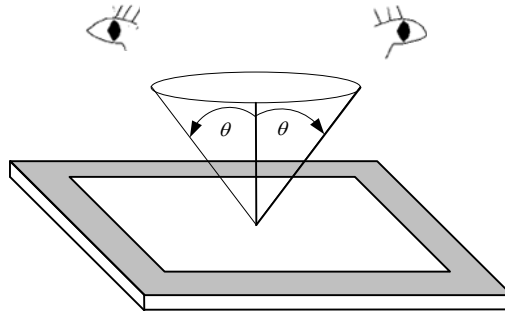

Fig. 11.1

## 11.1 THE DEFINITION OF LCD ZONE

LCD panel is divided into 2 areas as shown in Fig.11.2 for appearance specification in next section. A zone is the LCD active area (dot area); B zone is the area between A zone and metal frame.

In terms of housing design, B zone is the recommended window area customers' housing should be located in.

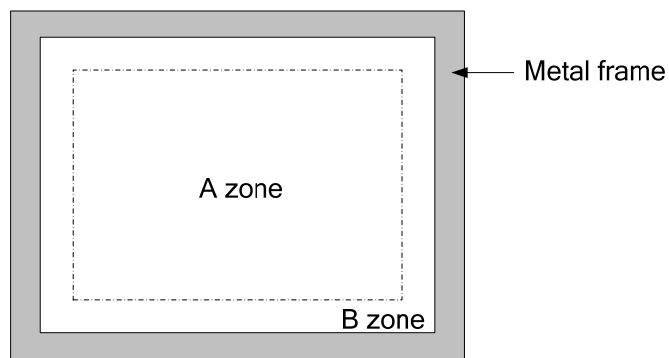

Fig. 11.2

## 11.2 LCD APPEARANCE SPECIFICATION

The specification as below is defined as the amount of unexpected phenomenon or material in different zones of LCD panel. The definitions of length, width and average diameter using in the table are shown in Fig. 11.4 and Fig. 11.5.

Item	Criteria				Applied zone
	Length (mm)	Width (mm)	Maximum number	Minimum space	
Scratches	$L \leq 15$	$W \leq 0.02$	Ignored	-	A
	$L \leq 15$	$0.02 < W \leq 0.1$	5	-	
	$L > 15$	$0.1 < W$	0	-	
Dent	Serious one is not allowed				A
Wrinkles in polarizer	Serious one is not allowed				A
Bubbles on polarizer	Average diameter (mm)		Maximum number		A
	$D < 0.3$		Ignored		
	$0.3 \leq D \leq 0.6$		4		
	$0.6 < D$		0		
1) Stains 2) Foreign Materials 3) Dark Spot	Filamentous (Line shape)				A
	Length (mm)	Width (mm)	Maximum number		
	$L \leq 2.0$	$W \leq 1.5$	5		
	$L > 2.0$	$1.5 < W$	0		
	Round (Dot shape)				A
	Average diameter (mm)	Maximum number	Minimum Space		
	$D < 0.2$	Ignored	-		
	$0.2 \leq D \leq 0.6$	4	-		
		$0.6 < D$	0	-	
	Those wiped out easily are acceptable				
Dot-Defect		Area①	Area②	Maximum number	A (Note 1)
	Bright dot-defect	1 dot	2 dot	3 dot	
	Dark dot-defect	2 dot	3 dot	4 dot	
	Bright + Dark point	3 dot	4 dot	5 dot	

Note 1: The Dot-Defect inspection within A zone (active area) would be divided into area ①, ② as Fig. 11.3 shown.

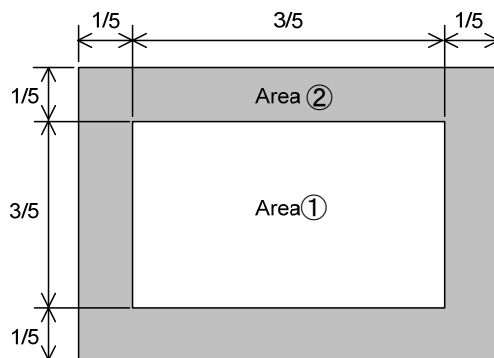

Fig. 11.3

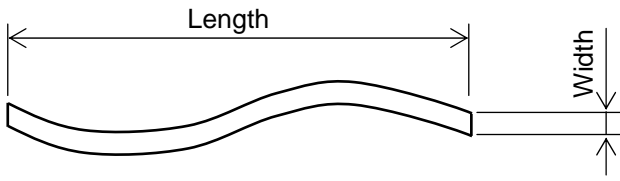
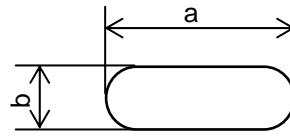

Fig 11.4



$$\text{Average diameter} = \frac{a+b}{2}$$

Fig 11.5

## 12. PRECAUTIONS

### 12.1 PRECAUTIONS of ESD

- 1) Before handling the display, please ensure your body has been connected to ground to avoid any damages by ESD. Also, do not touch display's interface directly when assembling.
- 2) Please remove the protection film very slowly before turning on the display to avoid generating ESD.

### 12.2 PRECAUTIONS of HANDLING

- 1) In order to keep the appearance of display in good condition; please do not rub any surfaces of the displays by sharp tools harder than 3H, especially touch panel, metal frame and polarizer.
- 2) Please do not pile the displays in order to avoid any scars leaving on the display. In order to avoid any injuries, please pay more attention for the edges of glasses and metal frame, and wear finger cots to protect yourself and the display before working on it.
- 3) Touching the display area or the terminal pins with bare hand is prohibited. This is because it will stain the display area and cause poor insulation between terminal pins, and might affect display's electrical characteristics furthermore.
- 4) Do not use any harmful chemicals such as acetone, toluene, and isopropyl alcohol to clean display's surfaces.
- 5) Please use soft cloth or absorbent cotton with ethanol to clean the display by gently wiping. Moreover, when wiping the display, please wipe it by horizontal or vertical direction instead of circling to prevent leaving scars on the display's surface, especially polarizer.
- 6) Please wipe any unknown liquids immediately such as saliva, water or dew on the display to avoid color fading or any permanently damages.
- 7) Maximum pressure to the surface of the display must be less than  $1.96 \times 10^4$  Pa. If the area of adding pressure is less than  $1 \text{ cm}^2$ , the maximum pressure must be less than 1.96N.

### 12.3 PRECAUTIONS OF OPERATING

- 1) Please input signals and voltages to the displays according to the values defined in the section of electrical characteristics to obtain the best performance. Any voltages over than absolute maximum rating will cause permanent damages to this display. Also, any timing of the signals out of this specification would cause unexpected performance.
- 2) When the display is operating at significant low temperature, the response time will be slower than it at  $25 \text{ C}^\circ$ . In high temperature, the color will be slightly dark and blue compared to original pattern. However, these are temperature-related phenomenon of LCD and it will not cause permanent damages to the display when used within the operating temperature.
- 3) The use of screen saver or sleep mode is recommended when static images are likely for long periods of time. This is to avoid the possibility of image sticking.
- 4) Spike noise can cause malfunction of the circuit. The recommended limitation of spike noise is no bigger than  $\pm 100 \text{ mV}$ .



## 12.4 PRECAUTIONS of STORAGE

If the displays are going to be stored for years, please be aware the following notices.

- 1) Please store the displays in a dark room to avoid any damages from sunlight and other sources of UV light.
- 2) The recommended long-term storage temperature is between 10 C° ~35 C° and 55%~75% humidity to avoid causing bubbles between polarizer and LCD glasses, and polarizer peeling from LCD glasses.
- 3) It would be better to keep the displays in the container, which is shipped from KOE, and do not unpack it.
- 4) Please do not stick any labels on the display surface for a long time, especially on the polarizer.

### 13. DESIGNATION of LOT MARK

1) The lot mark is showing in Fig.13.3. First 4 digits are used to represent production lot, T represented made in Taiwan, and the last 6 digits are the serial number.

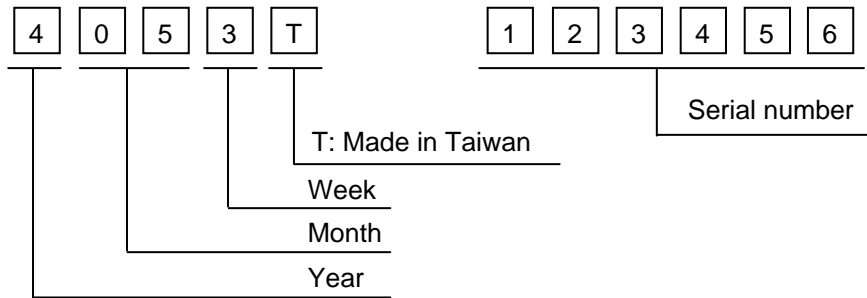

2) The tables as below are showing what the first 4 digits of lot mark are shorted for.

Year	Mark
2014	4
2015	5
2016	6
2017	7
2018	8

Month	Mark	Month	Mark
1	01	7	07
2	02	8	08
3	03	9	09
4	04	10	10
5	05	11	11
6	06	12	12

Week (Days)	Mark
1~7	1
8~14	2
15~21	3
22~28	4
29~31	5

3) Except letters I and O, revision number will be shown on lot mark and following letters A to Z.

4) The location of the lot mark is on the back of the display shown in Fig. 13.3.



Fig 13.3