

Precision Shaft Blocks GW ISO Series 3

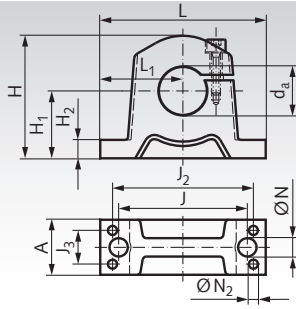

Material: Extruded aluminium.
Light Design, matching linear-bearing units of ISO Series 3.

Robust machine elements to attach the guiding shafts of the linear bearings. They allow true to size and cost efficient constructions.

Ordering Details: e.g.: Product No. 64640800, Precision Shaft Block GW, for Shaft-Ø 8 mm

Product No.	da mm	A mm	H ₁ ±0,01 mm	H ₂ mm	H mm	J mm	J ₂ mm	J ₃ mm	L mm	L ₁ mm	N mm	N ₂ mm	Weight g
646 408 00	8	10	15	5,5	25	25	35	5	45	22,5	4,3	2,7	12
646 412 00	12	12	20	6	32,5	32	42	6	52	26	5,3	3,2	23
646 416 00	16	15	20	7	35,5	40	46	7,5	56	28	5,3	4,3	34
646 420 00	20	20	25	8	43,5	45	58	10	70	35	5,3	5,3	65
646 425 00	25	28	30	10	53	60	68	16	80	40	6,4	6,4	140
646 430 00	30	30	35	10	63	68	76	18	88	44	8,4	6,4	200
646 440 00	40	36	45	12	81	86	94	22	108	54	10,5	8,4	470
646 450 00	50	49	50	14	92,5	108	116	30	135	67,5	10,5	10,5	680

Shaft steel page 539.

Precision Shaft Blocks GW-3 ISO Series 3

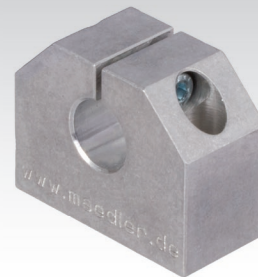
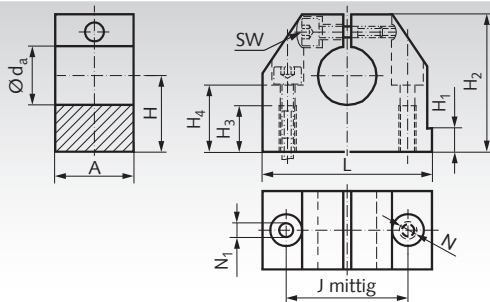

Material: Extruded aluminium.
Matching linear-bearing units of ISO Series 3.

Robust machine elements to attach the guiding shafts of the linear bearings. They allow true to size and cost efficient constructions.

Ordering Details: e.g.: Product No. 64641201, Precision Shaft Block GW-3, for Shaft-Ø 12 mm

Product No.	da mm	A mm	H±0,02 mm	H ₁ mm	H ₂ mm	H ₃ mm	H ₄ mm	J±0,12 mm	L mm	N ₁ mm	N* mm	sw mm	Weight g
646 412 01	12	20	20	6	35	13	16,5	30	43	5,6	M6	3	60
646 416 01	16	24	25	7	42	18	21	38	53	7,5	M8	4	110
646 420 01	20	30	30	7,5	50	22	25	42	60	9,4	M10	5	170
646 425 01	25	38	35	8,5	61	26	30	56	78	11,2	M12	6	340
646 430 01	30	40	40	9,5	70	26	34	64	87	11,2	M12	6	460
646 440 01	40	48	50	11	90	34	44	82	108	15,1	M16	8	900
646 450 01	50	58	60	11	105	43	49	100	132	17,5	M20	10	1450

* When mounting from the bottom side choose the next smaller screw size.

Shaft steel page 539.