

DO NOT SCALE DRAWING

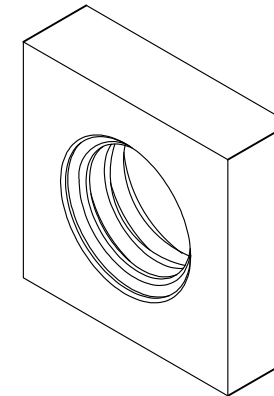
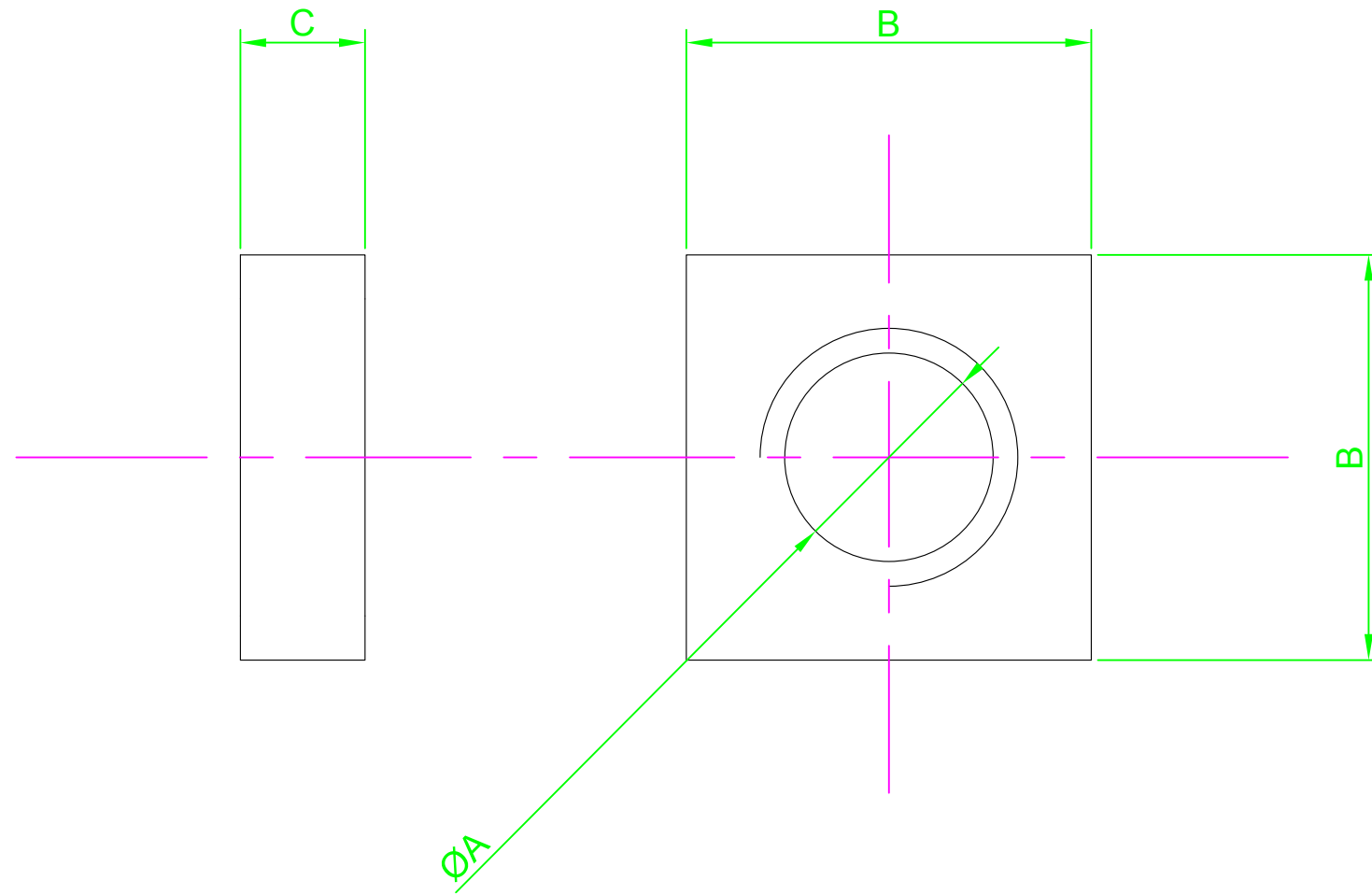

REVISION

A INITIAL DRAWING 29.9.15

Part Number	ØA	B Max	C Max
M3 - SQST- Z100	M3-0.5	5.5	1.8
M4 - SQST- Z100	M4-0.7	7.0	2.2
M5 - SQST- Z100	M5-0.8	8.0	2.7
M6 - SQST- Z100	M6-1.0	10.0	3.2

NOTES:



UNLESS OTHERWISE SPECIFIED:
DIMENSIONS ARE IN MM (Millimeters)
SURFACE FINISH:
TOLERANCES: DIN 562

MATERIAL:
Steel

TITLE:
Square Thin Nut DIN 562

	NAME	DATE
DRAWN	Darryl Wilson	29.09.15
CHK'D		
APPVD		

HEAT TREATMENT:

DESIGN RIGHT. TR FASTENINGS LTD, 2003
UNDER NO CIRCUMSTANCES MUST THIS
DRAWING BE COPIED OR DISCLOSED
WITHOUT FIRST OBTAINING WRITTEN
AUTHORITY.

CUSTOMER PART NUMBER:
N/A

FINISH:
Commercial Zinc/Clear Trivalent

DRAWING NUMBER:
TR32SQST-DIN562

A4

PROJECTION

