

Boost click

PID: MIKROE-2780

Use our new boost converter to step up the voltage in your next project.

Boost click carries Microchip's [MIC2606](#), a 2MHz, PWM DC/DC boost switching regulator available in a 2mm x 2mm MLF® package.

Boost click provides an adjustable output voltage through the onboard DAC that drives the FB pin of the MIC2606 to set desired output voltage. The click also has an onboard ADC that converts output voltage and sends its digital value through SPI pins of mikroBUS™ to the microcontroller.



How the click works

As you can see from the image there are **two onboard screw terminals**. One is for connecting the external VIN and the other is for connecting the load. The microcontroller reads the output voltage through the SPI from the onboard ADC and according to the desired output voltage, sends calculated data through SPI to an onboard DAC.

The DAC drives the FB pin of the MIC2606 to set desired output voltage. The output voltage must always be set greater than the input voltage, otherwise, performance is not guaranteed. Instead of connecting external VIN it is possible to use 5V from mikroBUS. This is done by changing the positions of two onboard jumpers from position EXT to position 5V. **Note:** Both of them must be in position 5V, otherwise performance is not guaranteed.

Boost click features

MIC2606 is a 0.5A, 2MHz Wide Input Range Boost Regulator with Integrated Switch and Schottky Diode. It's FB (feedback) pin provides the control path to control the output. This FB pin is driven by an onboard DAC – MCP4921. This is a 2.7 – 5.5V, low-power, low DNL, 12-Bit Digital-to-Analog Converter (DAC) with SPI interface. It provides high accuracy and low noise performance for industrial applications. The output voltage is connected to an onboard ADC - MCP3551 - through a voltage divider. MCP3551 is a 2.7V to 5.5V low-power, 22-bit Delta-Sigma Analog-to-Digital Converter.

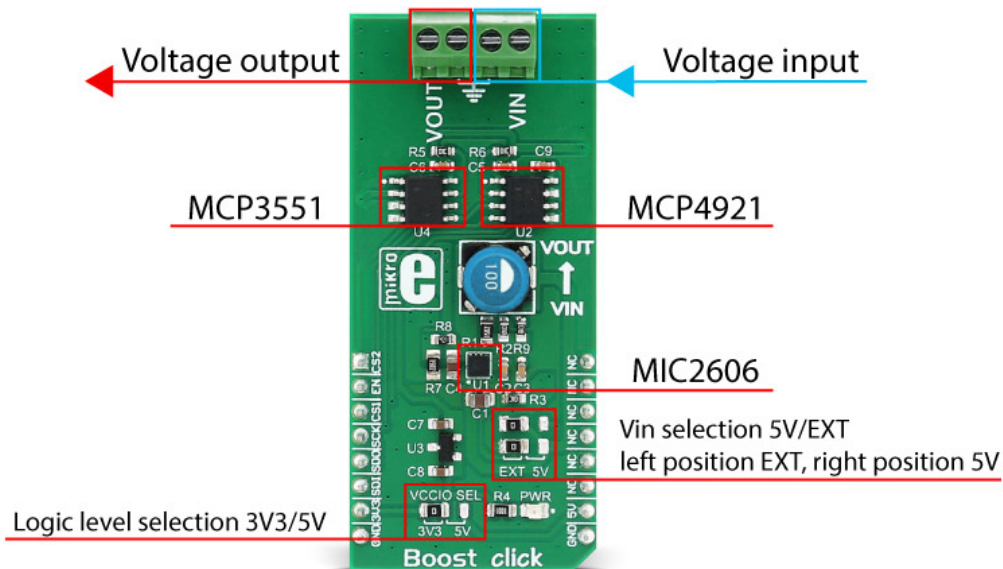

The reference voltage for both the ADC and DAC is provided by MAX6106 – onboard voltage reference.

Specifications

Type	Boost
Applications	Any applications where it is necessary to step up the voltage
On-board modules	MIC2606, MCP3551, MCP4921
Interface	SPI
Input Voltage	3.3V or 5V
Click board size	L (57.15 x 25.4 mm)

Pinout diagram

This table shows how the pinout on **Boost click** corresponds to the pinout on the mikroBUS™ socket (the latter shown in the two middle columns).

Notes	Pin	 mikro™ BUS				Pin	Notes
		1	AN	PWM	16		
DAC chip select	CS2	1	AN	PWM	16	NC	
MIC2606 enable	EN	2	RST	INT	15	NC	
ADC chip select	CS1	3	CS	TX	14	NC	
SPI clock pin	SCK	4	SCK	RX	13	NC	
SPI slave data out pin	SDO	5	MISO	SCL	12	NC	
SPI slave data in pin	SDI	6	MOSI	SDA	11	NC	
Power supply	+3.3V	7	3.3V	5V	10	+5V	Power supply
Ground	GND	8	GND	GND	9	GND	Ground

Jumpers and settings

Designator	Name	Default Position	Default Option	Description
JP1	VCCIO SEL	Left	3V3	Logic level selection 3V3/5V, left position 3V3, right position 5V
JP2	VIN SEL	Left	EXT	Vin selection 5V/EXT, left position EXT, right position 5V
JP3	VIN SEL	Left	EXT	Vin selection 5V/EXT, left position EXT, right position 5V

JP1 - this jumper allows you to select the logic level voltage for the communication lines. It can be 3.3V or 5V and must be paired with the supply voltage of the host microcontroller.

JP2 and JP3 - these jumpers serve to select the input voltage of the MIC2606. Both jumpers must always be in the same position and move simultaneously. If they are in the left position, (EXT) then the input voltage is taken from the connector VIN, if they are in the right position, (5V) then the input voltage is taken from the mikroBUS™ and it is 5V.

Maximum ratings

Description	Min	Typ	Max	Unit
VIN	7 ⁽¹⁾	...	20 ⁽¹⁾	V
		5 ⁽²⁾		
VOUT	15 ⁽¹⁾	...	38	V
	12 ⁽²⁾	...	38	

⁽¹⁾ If external supply is connected

⁽²⁾ If V_{IN} is 5V from mikroBUS