

LEH3
Data sheet

 Epishine



A smarter way to power electronics

Table of Contents

0 Epishine's Indoor Solar Cell.....	1
1 Epishine Standard Modules.....	2
2 Electrical Characteristics.....	3
3 Dimensions.....	4
4 Thermal and Light Stability.....	5
5 Mechanical and Electrical Stability.....	5
6 Operating Conditions.....	6
7 Absorption Spectrum.....	7
8 Instructions for Use.....	8



Create your smart electronics solution with our indoor solar cells

For simple integration, unparalleled flexibility and market-leading performance, choose our products as your source of power.

Key Features:

- Low climate footprint
- Flexible and lightweight
- Typical output power of $22\mu\text{W}/\text{cm}^2$ at 500 lux¹
- Crafted from organic materials
- Made in Sweden
- Our multicell product range allows you to pick an output voltage best suited for your electronics design

¹See section 6 for standard measurement conditions



About Epishine

We are a Swedish manufacturing company specialized in the production of printed light harvesting modules. Our core innovations enable smart electronics to meet the growing demand for sustainable energy solutions. The product line presented within consists of a series of light harvesting modules optimized for indoor lighting conditions, offering easy integration into various applications.

For more information visit epishine.com

1 Epishine Standard Modules

Epishine light harvesting Modules come in three standard sizes suitable for a variety of applications. Available for purchase via epishine.com. For more detailed drawing see Section 3.

If our standard module sizes do not fit your requirements, we offer to customise shape and size. Contact info@epishine.com

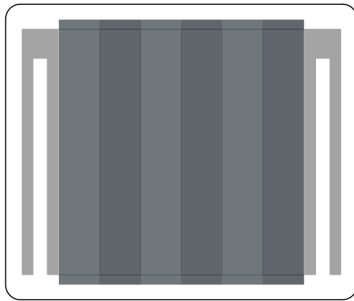

LEH3_50x50_6



LEH3_50x30_6



LEH3_50x20_6

Standard Module Code	# of cells	Aperture area (Active area) (cm ²)	MPP Voltage ¹ (V)	MPP Current ¹ (μA)	MPP Output Power ¹ (μW)	Open Circuit Voltage ¹ (V)
LEH3_50x50_4	4	25 (23)	2.08	224	467	2.61
LEH3_50x50_6	6	25 (22)	3.12	143	447	3.91
LEH3_50x50_8	8	25 (21)	4.16	102	426	5.22
LEH3_50x30_4	4	15 (13.8)	2.08	135	280	2.61
LEH3_50x30_6	6	15 (13.2)	3.12	86	268	3.91
LEH3_50x30_8	8	15 (12.6)	4.16	62	256	5.05
LEH3_50x20_4	4	10 (9.2)	2.08	90	187	2.61
LEH3_50x20_6	6	10 (8.8)	3.12	57	179	3.91
LEH3_50x20_8	8	10 (8.4)	4.16	41	171	5.22
LEH3_68x74_6	6	50.5 (46.5)	3.12	302	943	3.91

Table 1. Summary of products

¹ Typical values measured under standard measurement conditions in Section 6



2 Electrical Characteristics

Typical data from standard measurement conditions. See section 6 for details.

Power density as a function of illuminance

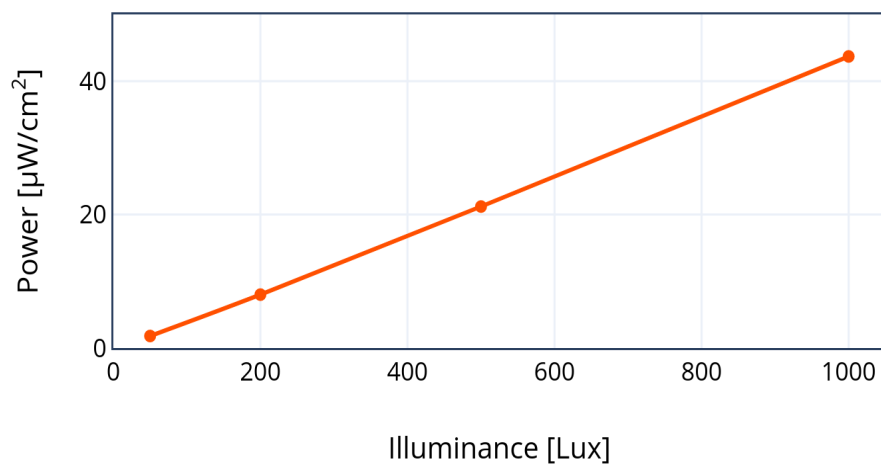

Power-Voltage characteristics

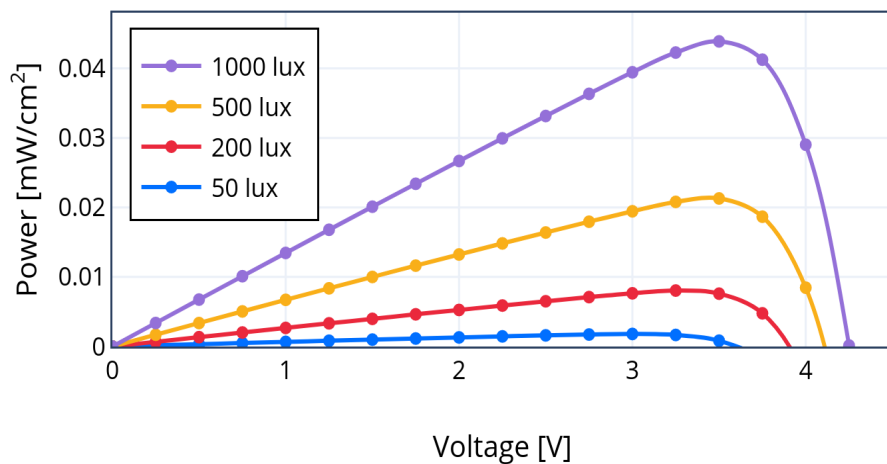

Current-Voltage characteristics

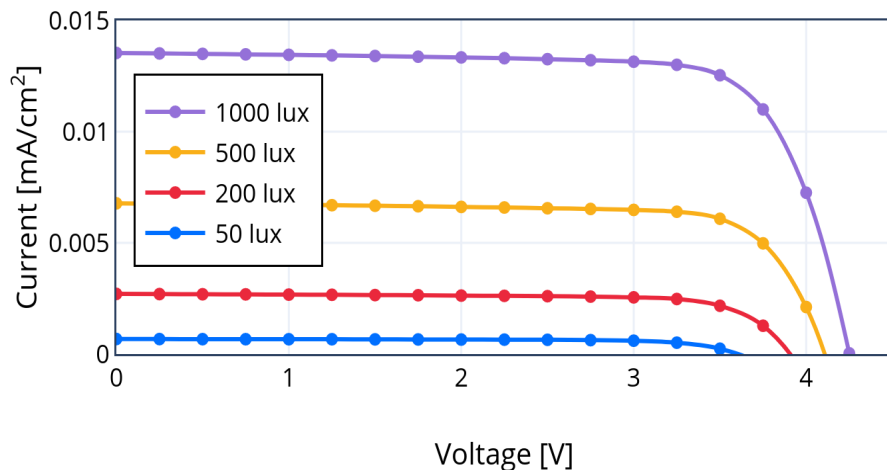

3 Dimensions

The position of the electrical contacts are indicated in the drawing in Figure 10
 The production tolerance of the physical dimensions of Epishine's modules is ± 0.1 if not specified otherwise.

Color of cells, busbars and electrodes might be subject to change.
 The LEH3_50x50 module in Figure 10 has a weight of 1.22g.

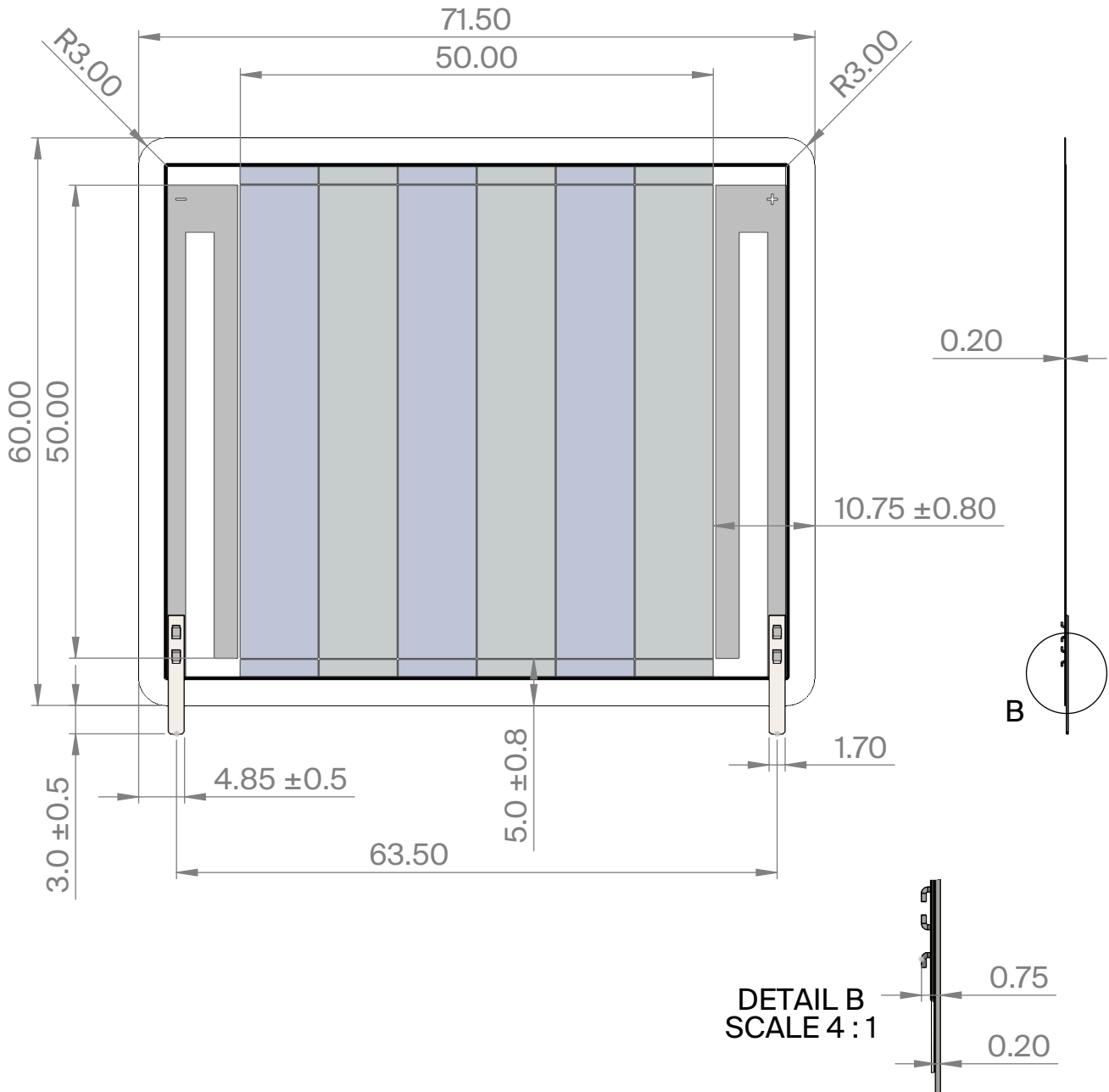

Figure 10. Mechanical dimensions and tolerances of Epishine's modules on the example of an LEH3_50x50_6 module.

The side shown in the drawing (with the contacting) should be facing inwards when assembled



4 Thermal and Light Stability

Epishine's modules are stress-tested in highly accelerated stress tests (HAST) to simulate accelerated aging. All tests are designed to be indicative of approximately 10 years service life, conditioned by standard operating conditions specified in Section 6. For clarification purposes, the aforementioned does not constitute a representation or warranty or binding commitment of Epishine. Warranties are exhaustively and exclusively provided for in Epishine's General Terms and Conditions, forming part of the purchase agreement.

<https://www.epishine.com/gtc>

Test	Test condition	Pass criterion	Comment
Accelerated Lifetime Test (Temperature and Humidity)	-20°C / 12%RH / 3000h	No power loss	Scancool SD-46
	55°C / 85%RH / 2000h	≤ 20% power loss	Vötsch VCL 4006 Climate Chamber
Temperature Cycling Test	-20°C to 70°C / 72cycles / 1.2h per cycle	No power loss	Performed by BK Services Linköping
High Illuminance Test	22°C / 45%RH / 42.000lux 3h/day / 100 days	≤ 5% power loss	Standby illumination 200lux

Table 2: Summary of environmental stress test conditions and pass criteria

5 Mechanical and Electrical Stability

Our modules feature a high flexibility. Mechanical stress tests are compiled in Table 3.

Test	Test condition	Pass criterion	Comment
Cycling Bending Test - Module	Bending radius 1cm / 180° / 10000 cycles	No power loss	Performed on automated bending tester
Drop test	Drop from 5m	No power loss	
Shipping Test	Storage at 0.75 bar for 14 hours 25°C / 45%RH / 0lux	No power loss	
ESD Immunity Test EN 61000-4-2	±4kV indirect discharges and direct contact charges ±8kV air discharges at 25°C /	No power loss	Performed by BK Services Linköping

Table 3. Summary of mechanical stress test conditions and pass criteria

6 Operating conditions

Standard operating conditions (SOC)

Temperature: $20 \pm 5^\circ\text{C}$

Humidity: 40%RH (non-condensing)

Illumination intensity: 20-1000 lux 8h/day

Different operating conditions may affect lifetime.

Typical output power density:

Lux	Min Power Density ¹ ($\mu\text{W}/\text{cm}^2$)	Mean Power Density ¹ ($\mu\text{W}/\text{cm}^2$)	Max Power Density ¹ ($\mu\text{W}/\text{cm}^2$)	MPP Voltage per cell ¹ (V/cell)
50	1.6	1.8	2	0.5
200	6.8	7.6	8.4	0.54
500	18.3	20.3	22.3	0.58

Table 4. Electrical characteristics of indoor solar cell

¹ Typical values measured under standard measurement conditions described in Section 6

Standard measurement conditions for electrical performance:

Temperature: $22 \pm 2^\circ\text{C}$

Humidity: $40 \pm 5\%$ RH

Illuminance: 500 ± 10 lux warm white LED. White background behind the module.

The electrical performance characterization lamp spectrum can be seen below

Electrical measurement and lamp calibration:

In order to ensure a standardized test environment measurement, equipment and lamps are calibrated at regular intervals. The light intensity is calibrated using a reference silicon solar cell of the type SRI 6014 with a KG5 filter, purchased from and calibrated by the National Institute of Standards and Technology (NIST). The calibration of the reference cell is to a warm white LED array.

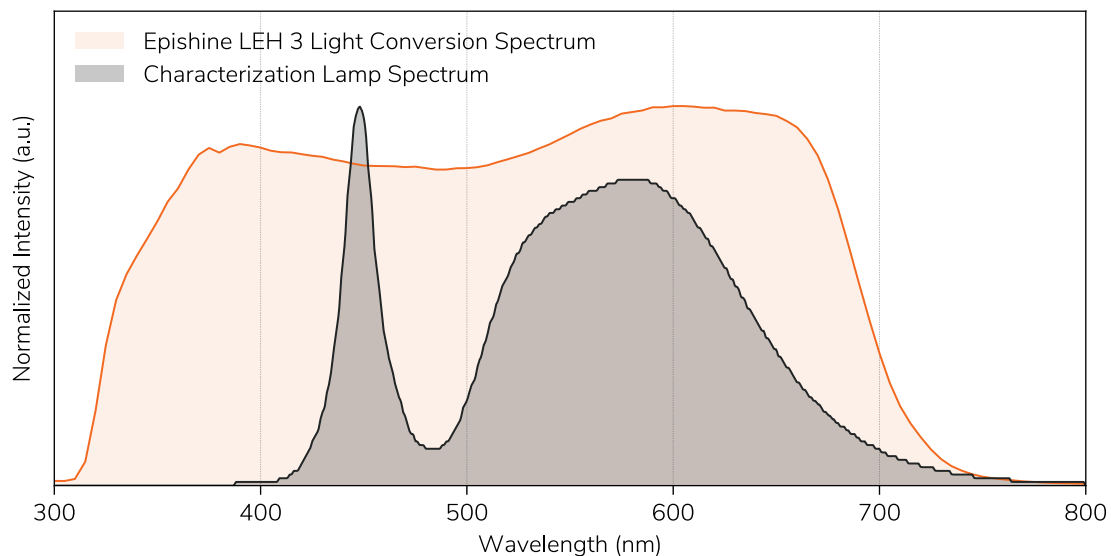

Figure 11. Indoor warm white LED characterization lamp spectrum (gray trace) and Epishine LEH 3 sensitivity (orange trace)



7 Absorption Spectrum

Different indoor light sources have different spectral distributions, resulting in different colors and luminosities. Epishine's active material is designed to capture light across the whole visible spectrum, covering all common indoor light sources. This fact is shown in Figure 12, where it can be seen that Epishine's conversion spectrum (orange) fully covers emission spectra for the most common indoor light sources.

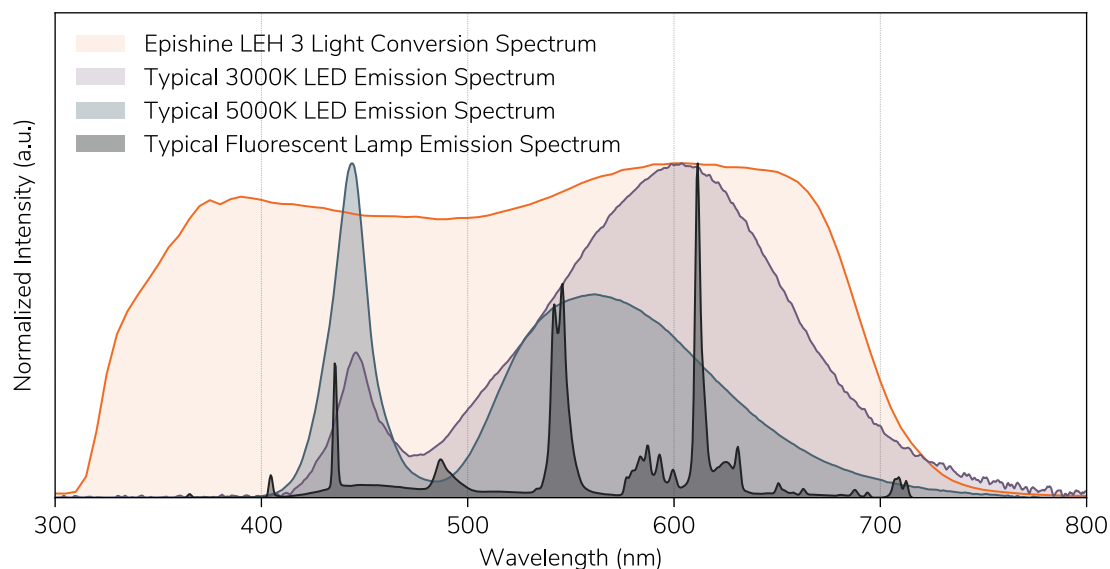

Figure 12. Sensitivity of Epishine Generation 3 LEH modules (orange trace) in comparison to typical indoor light sources

8 Instructions of use

Contact info@epishine.com if you want to get access to our knowledge base and information regarding how to do mechanical and electrical integration into a variety of electronic devices.

Please note that information related to the products and services supplied by Epishine may be subject to updates continuously without prior notice. Please contact Epishine or visit epishine.com for updates.

Storage

Epishine recommends storing LEH modules at temperatures below 30°C as long-term storage at higher temperatures may have an adverse impact on their lifetime.

Store under normal indoor light. If stored in darkness storage time is limited to 6 months. Dark storage may impact lifetime.

Cautions before use¹

Epishine LEH modules are sensitive to excessive heat. Over-heating for extended periods of time may result in degradation of performance and lifetime.

Epishine LEH modules are designed for indoor use and are sensitive to high light intensities.

Placing the modules in direct sunlight for a prolonged time may result in degradation of performance and lifetime.

Occasional short exposure to strong light intensities, e.g. sunlight through a window glass, will not affect their performance or lifetime.

For optimal performance use a white background reflector such as white copying paper or similar, directly behind the Epishine LEH module.

Epishine LEH modules may not be folded or cut.

Epishine LEH modules may lose functionality if attached to a surface with double adhesive tape and pulled off again.

Use care if solder-pads are mechanically modified such as bending or cutting.

Soldering and assembly

Epishine modules are designed for direct soldering to PCB or wires using a manual soldering iron, a hot bar soldering jig, conductive adhesive, ultrasonic or laser welding.

Ensure short heating time of the solder-pad to limit heat transfer to the plastic foil.

Epishine modules are NOT SUITABLE for infrared or hot-air reflow soldering.

Epishine recommends the use of a water-soluble flux, or a no-clean (low residue) flux, and low temperature solder compounds.

Soldering on the solder pads should only be done in well ventilated areas.

Please consult Epishine if you wish to clean the device after soldering.

¹See section 6 for standard operating conditions (SOC)



This symbol on the product and / or accompanying documents means that used electrical and electronic equipment (WEEE) should not be mixed with general household waste. For proper treatment, recovery and recycling, please take this product to designated collection points where it will be accepted free of charge.