

Customer Information Sheet

DRAWING No.: M80-2060005

IF IN DOUBT - ASK

©

NOT TO SCALE

THIRD ANGLE PROJECTION

ALL DIMENSIONS IN mm

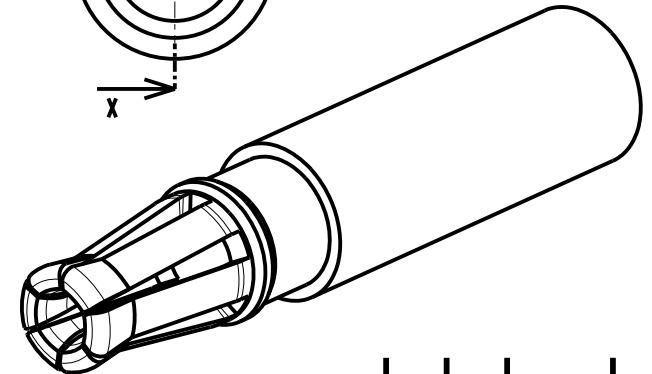
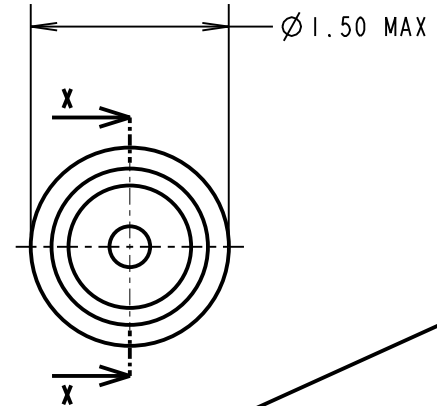
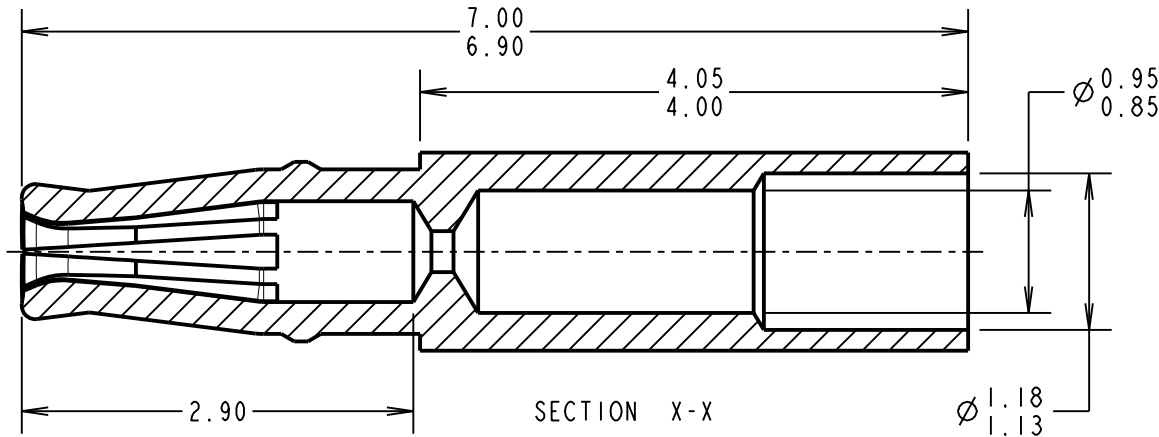

SPECIFICATION:

MATERIAL:

BERYLLIUM COPPER

FINISH:

0.76-1.00µm GOLD OVER 1.5-2.5µm NICKEL

MECHANICAL:

INSERTION FORCE = 4.0N MAX

WITHDRAWAL FORCE = 0.5N MIN

DURABILITY = 1000 OPERATIONS

ENVIRONMENTAL:

OPERATING TEMPERATURE = -55°C TO +125°C

FOR COMPLETE CONNECTOR SPECIFICATION, SEE COMPONENT SPECIFICATION CO05XX (LATEST ISSUE).

NOTES:

- SUITABLE FOR WIRE GAUGE 22AWG. MAXIMUM INSULATION DIAMETER 1,10mm, BS3G210 TYPE A RECOMMENDED. SEE CABLE SPEC. C049XX FOR OTHER WIRE TYP OPTIONS. STRIP WIRE BY 2.00mm FOR CRIMPING.
- RECOMMENDED HAND CRIMP TOOL = M22520/2-01 WITH POSITIONER Z80-444.
- FOR INSTRUCTIONS ON HAND CRIMP TOOL M22520/2-01, SEE INSTRUCTION SHEET IS-01.
- PACKING: 100 PIECES PER BAG.
- PATENTED TECHNOLOGY.

MGP	9	14.05.21	30543
NAME	ISS.	DATE	CN/CO
APPROVED: MGP			
CHECKED: RTP			
DRAWN: M.PERREN			
CUSTOMER REF.:			
ASSEMBLY DRG:			

HARWIN

www.harwin.com
technical@harwin.com

THIS DRAWING AND ANY INFORMATION OR DESCRIPTIVE MATTER SET OUT HEREON ARE CONFIDENTIAL AND COPYRIGHT PROPERTY OF THE HARWIN GROUP AND MUST NOT BE DISCLOSED, LOANED, COPIED OR USED FOR MANUFACTURING, TENDERING OR FOR ANY OTHER PURPOSE WITHOUT THEIR WRITTEN PERMISSION.

TOLERANCES

X. = ±1mm
X.X = ±0.50mm
X.XX = ±0.20mm
X.XXX = ±0.01mm

ANGLES = ±5°
UNLESS STATED

MATERIAL:

SEE ABOVE

FINISH: SEE ABOVE

S/AREA: 51.2 mm²

TITLE:

T-CONTACT FEMALE 22AWG CRIMP

DRAWING NUMBER:

M80-2060005

SHT
2 OF 2